

LIBRARY
ROYAL AIRCRAFT ESTABLISHMENT
BEDFORD



MINISTRY OF AVIATION

AERONAUTICAL RESEARCH COUNCIL

CURRENT PAPERS

Free-Flight Measurements of the
Dynamic Longitudinal-Stability
Characteristics of a Wind Tunnel
Interference Model ($M = 0.92$ to 1.35)

by

G. H. Greenwood

LONDON: HER MAJESTY'S STATIONERY OFFICE

1963

THREE SHILLINGS NET

U.D.C. No. 533.6.071.33/.4 : 533.6.013.412 :
533.6.013.423 : 533.6.011.35 : 533.6.055

C.P. No. 648

November, 1961

FREE-FLIGHT MEASUREMENTS OF THE DYNAMIC LONGITUDINAL-STABILITY
CHARACTERISTICS OF A WIND TUNNEL INTERFERENCE MODEL ($M = 0.92$ TO 1.35)

by

G. H. Greenwood

SUMMARY

The dynamic longitudinal-stability characteristics of a standard wind tunnel interference model have been investigated in free flight over a Mach number range of 0.92 to 1.35.

Measurements of lift-curve slope and manoeuvre margin were obtained, and are compared with results from transonic-tunnel tests under low blockage conditions.

The analysis was extended to obtain damping derivatives to allow comparison to be made with possible future dynamic tests in wind tunnels on the standard shape.

LIST OF CONTENTS

	<u>Page</u>
1 INTRODUCTION	3
2 DESCRIPTION OF THE MODEL	3
3 TEST TECHNIQUE	3
4 METHOD OF ANALYSIS	4
4.1 Pitching-moment derivative m_w	4
4.2 Manoeuvre margin m_w/z_w	4
4.3 Lift-curve slope z_w	5
4.4 Damping in pitch	5
5 RESULTS AND DISCUSSION	5
6 CONCLUSIONS	6
LIST OF SYMBOLS	6
LIST OF REFERENCES	7
TABLE 1 - Particulars of the model	8
ILLUSTRATIONS - Figs.1-13	-
DETACHABLE ABSTRACT CARDS	

LIST OF ILLUSTRATIONS

	<u>Fig.</u>
Standard model shape	1
Details of free-flight model	2
Photograph of free-flight model	3
Photograph of boosting arrangement	4
Portion of telemetry record	5
Typical analysis of one oscillation ($M = 1.17$)	6(a-c)
Determination of frequency	6a
" " focal point	6b
" " damping	6c
Variation of m_w with Mach number	7
Variation of z_w with Mach number	8
Free-flight/tunnel comparison of m_w	9
Free-flight/tunnel comparison of z_w	10
Free-flight/tunnel comparison of manoeuvre margin $\left(\frac{\partial C_m}{\partial C_L}\right)$	11
Total pitch-damping	12
Rotary pitch-damping	13

1 INTRODUCTION

The investigation described in this Note was part of the free-flight model contribution to a programme of tests designed to investigate wall-interference effects in transonic tunnels¹.

This programme included measurements of body pressures, drag, lift-curve slope and aerodynamic-centre position made in the tunnels and in free-flight, using models of a standard shape but varying in scale.

The free-flight measurements of body pressures and drag have already been reported^{1,2}; the purpose of this Note is to describe the free-flight measurements of the longitudinal-stability derivatives (m_w and z_w) and to show how they compare with corresponding tunnel measurements.

The free-flight tests also yielded information on damping and these results have been included for comparison with possible future dynamic measurements in a wind tunnel.

2 DESCRIPTION OF THE MODEL

The shape of the free-flight model followed as closely as possible the standard shape shown in Fig.1 but small fins had to be mounted on the body to ensure directional stability, and an incidence-measuring device was added to the body nose (Figs.2 and 3).

The model was equipped with a 465 Mc/s telemetry set recording the following quantities:-

- (a) Normal accelerations at four stations along the body.
- (b) Lateral accelerations at the centre of gravity.
- (c) Angle of incidence (derived from the measured pressure difference on a hemispherical nose probe).
- (d) Longitudinal accelerations.

To ensure turbulent boundary-layer conditions over the whole wing, for comparison with tunnel tests, transition was fixed on the wing leading edge by adding roughness bands in the position shown in Fig.2.

3 TEST TECHNIQUE

In the present test the model was boosted to the required test velocity by a single fin-stabilised rocket motor (Fig.4) which fell away when its thrust was spent thus allowing the model to coast on in free flight.

During the coasting flight the model was disturbed in the pitch plane by firing small model-borne pulse rockets. Nine such rockets were carried and were fired singly at approximately equal Mach number intervals. Each disturbance resulted in a short-period oscillation whose characteristics were measured by the normal accelerometers disposed along the body length and by the nose incidence probe. From these measurements the dynamic-stability derivatives were deduced by the methods described in Ref.3.

A portion of the telemetry record showing the response from the nose probe and several of the normal accelerometers is presented in Fig.5.

Longitudinal and lateral accelerations were also measured, the former to provide an alternative source for deriving velocity and the latter to provide, in the first instance, a qualitative assessment of the magnitude of any coupled motions that might be present*.

Oscillations were induced during the model flight at Mach numbers of 1.35, 1.29, 1.25, 1.17, 1.10, 1.03, 0.98, 0.94 and 0.91 but only a limited analysis was possible from that at 1.10 because the test data suggested that non-linear variations of lift and pitching moment with incidence were present. Thus the experimented values of z_w , m_w/z_w and damping have been omitted at this Mach number.

The inclusion of the incidence-measuring probe and the stabilising fins (Fig.2) should have a negligible effect on the pitch derivatives.

Velocity and trajectory were obtained from kine-theodolite data.

4 METHOD OF ANALYSIS

The methods of analysis employed in this Note are basically those described in Ref.3. Brief comments on the determination of individual derivatives are included here for completeness.

4.1 Pitching-moment derivative m_w

This derivative is primarily dependent upon the frequency of oscillation (equation 1) and can be determined to an accuracy of about $\pm 2\%$

$$m_w = -\frac{i_B}{\mu_1} (\omega_n \hat{t})^2 . \quad (1)$$

Comparison of frequencies derived from each of the four normal accelerometers allows a direct evaluation of the experimental uncertainties involved: frequency plots for one oscillation are given in Fig.6(a).

4.2 Manoeuvre margin m_w/z_w

The manoeuvre margin, m_w/z_w , is derived from the focal-point method described in detail in Ref.3. This method depends upon a comparison of amplitude measurements from several normal accelerometers and therefore gives rise to greater uncertainties than the derivation of m_w .

Fig.6(b) shows a typical plot of acceleration amplitude against instrument position from which the focal distance D is determined. The focal distance is related to the manoeuvre margin by the expression

$$\frac{m_w}{z_w} = \frac{i_B \bar{\omega}}{D} . \quad (2)$$

*Only very small lateral disturbances were found in the test and no analysis of the coupled motion was necessary.

4.3 Lift-curve slope z_w

Knowing m_w and m_w/z_w the lift-curve slope derivative z_w follows directly.

4.4 Damping in pitch

The damping of the oscillations in pitch was determined by conventional methods: Fig.6(c) shows a logarithmic plot of the normal-acceleration amplitudes from one oscillation. From such a plot the damping factor λ can be evaluated where

$$\lambda = \frac{1}{2t} \left(z_w + \frac{m_q + m_w}{i_B} \right). \quad (3)$$

Thus from λ one can obtain the total damping derivative $\left(z_w + \frac{m_q + m_w}{i_B} \right)$ and the rotary component of the damping $(m_q + m_w)$. The z_w values given in Fig.8 were used to evaluate $(m_q + m_w)$.

5 RESULTS AND DISCUSSION

In order not to confuse the significance of the free-flight results with comments on the merits and demerits of various transonic tunnels, only one set of tunnel results was chosen for the free-flight/tunnel comparison. These were obtained in the 9 ft x 8 ft perforated-wall tunnel of the Aircraft Research Association with a model of 2.5 inches body diameter*. A model of this size gives a tunnel blockage of 0.06%, - low enough to inhibit most of the tunnel-interference effects.

As discussed in the previous section, the most accurately determined derivative from the free-flight measurements is m_w and the tunnel/flight comparison of this quantity is particularly significant. The basic free-flight results are given in Fig.7 and these are compared with the tunnel results in Fig.9. All that need be said of this comparison is that the differences between the two curves are of the same magnitude as the known uncertainties in measurement appropriate to the two techniques, suggesting negligible tunnel-interference effects.

Somewhat greater differences between tunnel and free-flight are apparent in the comparison of manoeuvre margins (Fig.11). These amount to 3.5% at supersonic speeds - which is within the experimental uncertainty - and 9% at subsonic speeds - rather more than the expected experimental uncertainty. The basic free-flight experimental data in this region is of good quality and there is no obvious reason for a 9% discrepancy.

Added confirmation that the difference at subsonic speeds may be genuine is provided by the independently-determined values of m_w . The tunnel/flight comparison of Fig.9 also indicates a greater stability margin in flight than would be deduced from the tunnel results.

*The results were taken from A.R.A. Model Test Note Z5/1, 1958.

The compensating effects of these discrepancies in m_w and m_w/z_w is apparent in the tunnel/flight comparison of z_w (Fig.10). Now the two sets of results agree within the known uncertainties at all Mach numbers.

Little need be said of the damping results (Figs.12 and 13) except that they show the loss in damping at high subsonic Mach numbers which is characteristic of wings having this degree of thickness and sweep ($t/c = 0.06$ $\Lambda_{1/2} = 45^\circ$). A theoretical curve⁴ appropriate to the gross wing of the present model indicates that the theory is giving a fair account of the rotary damping at transonic speeds.

6 CONCLUSIONS

At supersonic speeds the measured values of m_w , z_w and manoeuvre margin derived from this free-flight investigation are in good agreement with results obtained from a perforated-wall transonic tunnel.

At subsonic speeds the differences between free-flight and tunnel values of m_w and manoeuvre margin are rather greater than one would expect from experimental uncertainty alone. The free-flight values of m_w and manoeuvre margin are derived by independent methods suggesting that the tunnel/free-flight discrepancy may be genuine.

LIST OF SYMBOLS

B	moment of inertia about the lateral axis
\bar{c}	aerodynamic mean chord
D	distance of centre of gravity to focal point
i_B	moment of inertia coefficient ($gB/W\bar{c}^2$)
R_E	Reynolds number
S	gross wing area
V	flight-path velocity
W	weight
m_w	$M_w/S\rho V\bar{c}$
z_w	$Z_w/S\rho V$
m_q	$M_q/S\rho V\bar{c}^2$
$m_{\dot{w}}$	$M_{\dot{w}}/S\rho V\bar{c}^2$
\hat{t}	unit of aerodynamic time ($\mu_1 \bar{c}/V$)
μ_1	relative density ($W/\rho S \bar{c} g$)

LIST OF SYMBOLS (CONTD)

λ	damping factor
ω	natural frequency of short-period longitudinal oscillation
ω_n	undamped natural frequency $(\omega^2 + \lambda^2)^{\frac{1}{2}}$
ρ	atmospheric density

LIST OF REFERENCES

<u>No.</u>	<u>Author</u>	<u>Title, etc.</u>
1	O'Hara, F. Squire, L.C. Haines, A.B.	An investigation of interference effects on similar models of different size in various transonic tunnels in the U.K. (A.R.A. Wind Tunnel Note No.27). February 1959. A.R.C. 21,094.
2	Greenwood, G.H.	Free-flight measurements of the zero-lift drag and base pressure on a wind tunnel interference model (M = 0.8-1.5). A.R.C. C.P.553. November 1960.
3	Hamilton, J.A. Hufton, P.A.	Free-flight techniques for high speed aerodynamic research. Journal of the Royal Aeronautical Society. March 1956.
4	Naysmith, A.	A collection of longitudinal stability derivatives of wings at supersonic speeds. A.R.C. 19061. June 1956.

TABLE 1

Particulars of the model

Wing:

Gross wing area	=	1.777 ft ²
Gross aspect ratio	=	2.83
Gross taper ratio	=	0.333
Sweepback of mid-chord line	=	45°
Sweepback of leading edge	=	53.5°
Wing section	=	R.A.E.102
Thickness/chord ratio	=	0.06
Aerodynamic mean chord (\bar{c})	=	0.8591 ft

Body:

Overall fineness ratio = 10.0

Nose is tangent circular ogive, with a tip radius of 0.025D, with fineness ratio of 3.6

Afterbody is cylindrical

All cross-sections are circular

Weight of model = 84.1 lb
Centre of gravity position = 0.378 \bar{c} ahead of L.E. \bar{c}
Inertia coefficient i_p , based on \bar{c} = 1.551

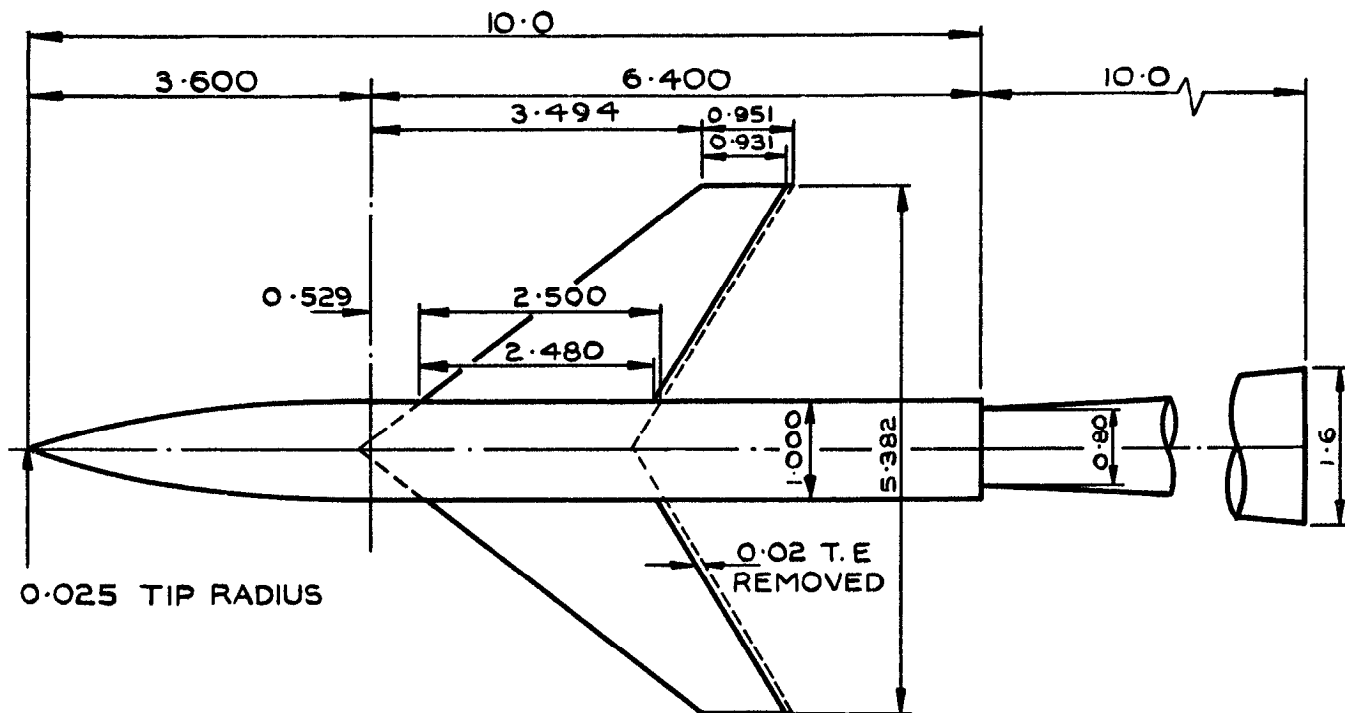

(ALL DIMENSIONS ARE IN BODY DIAMETERS)

FIG. 1. DETAILS OF STANDARD MODEL & STING.

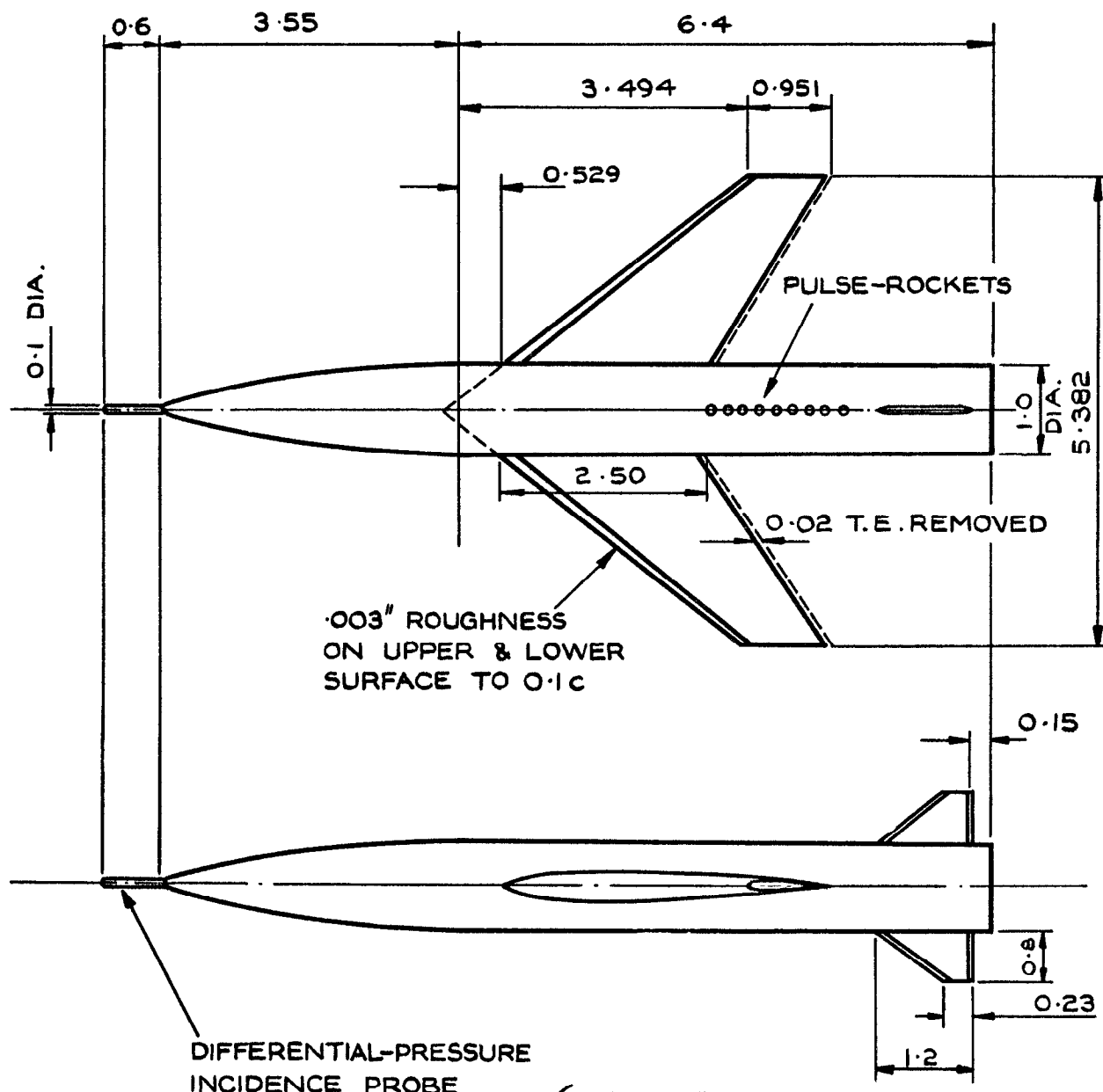

(ALL DIMENSIONS ARE IN BODY DIAMETERS)
BODY DIAMETER OF MODEL = 5.0 INCHES)

FIG. 2. DETAILS OF FREE-FLIGHT MODEL.

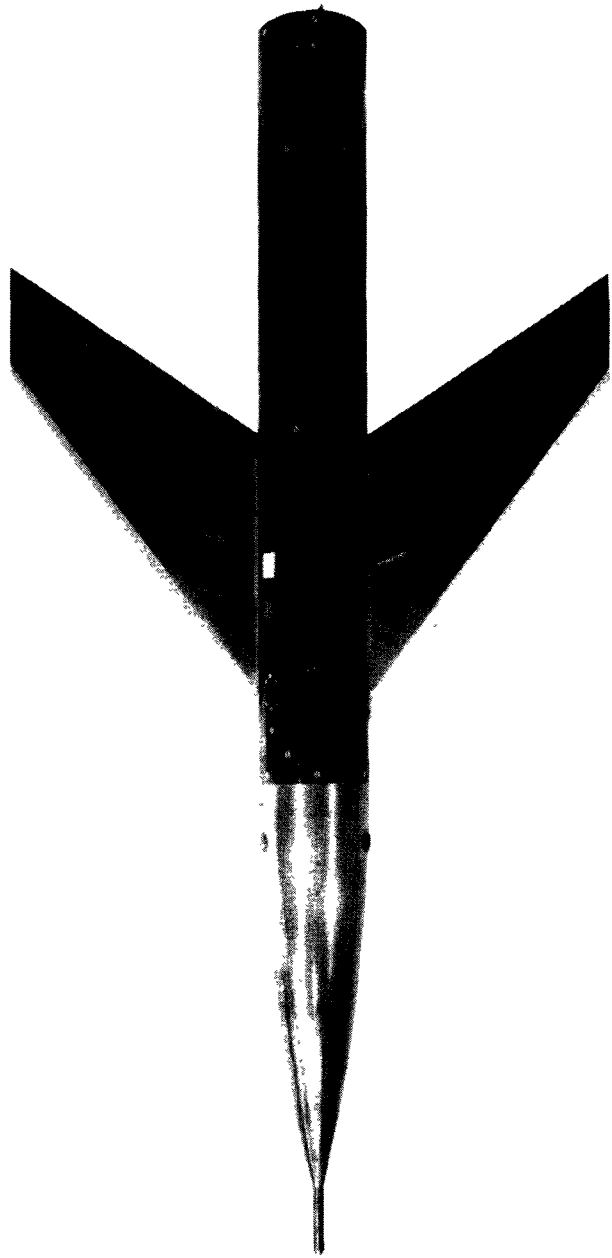

FIG.3. FREE-FLIGHT MODEL

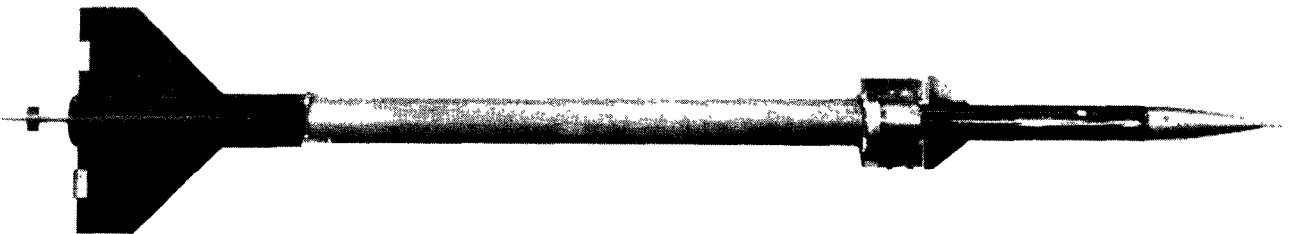

FIG.4. BOOSTING ARRANGEMENT

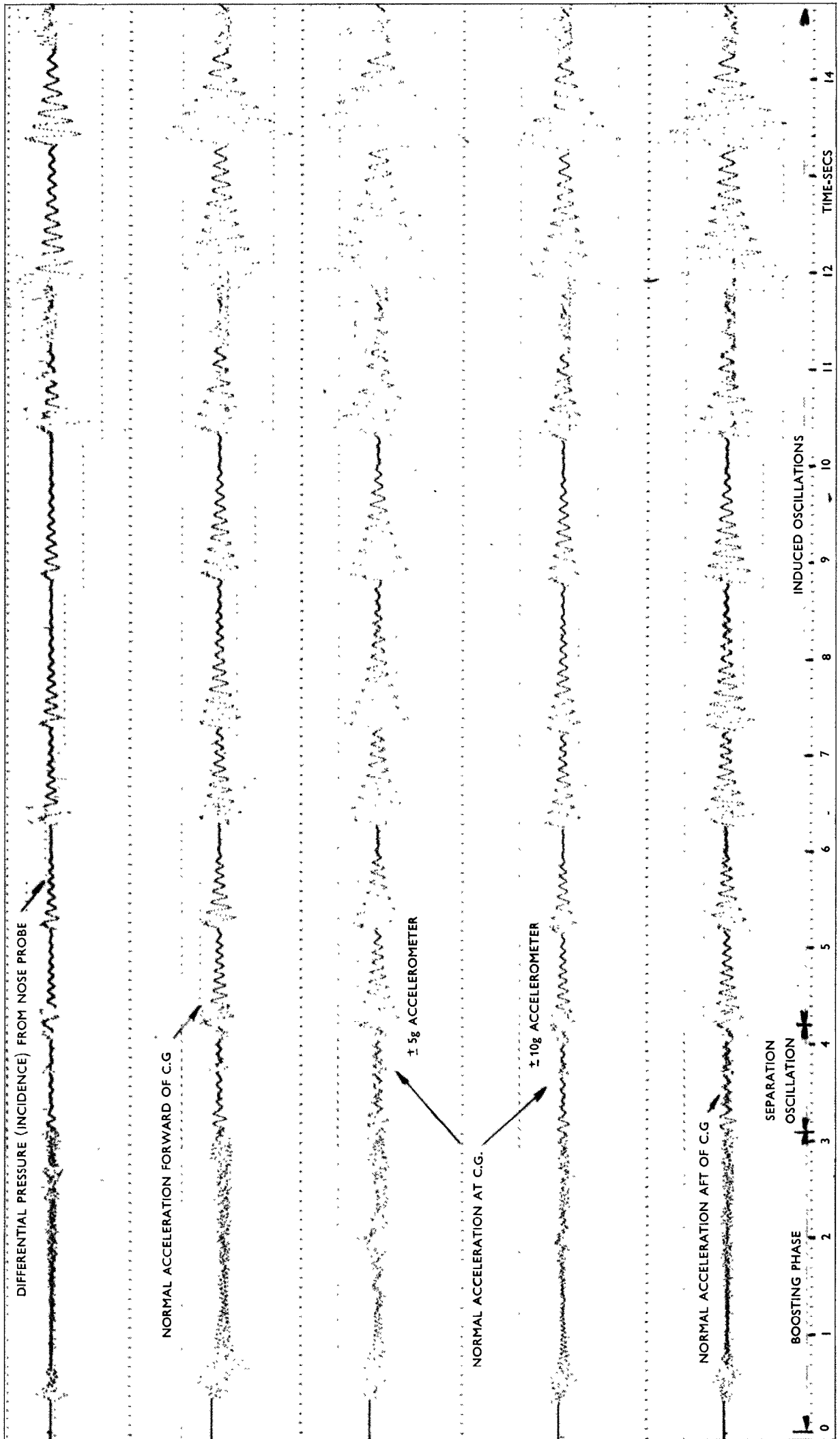
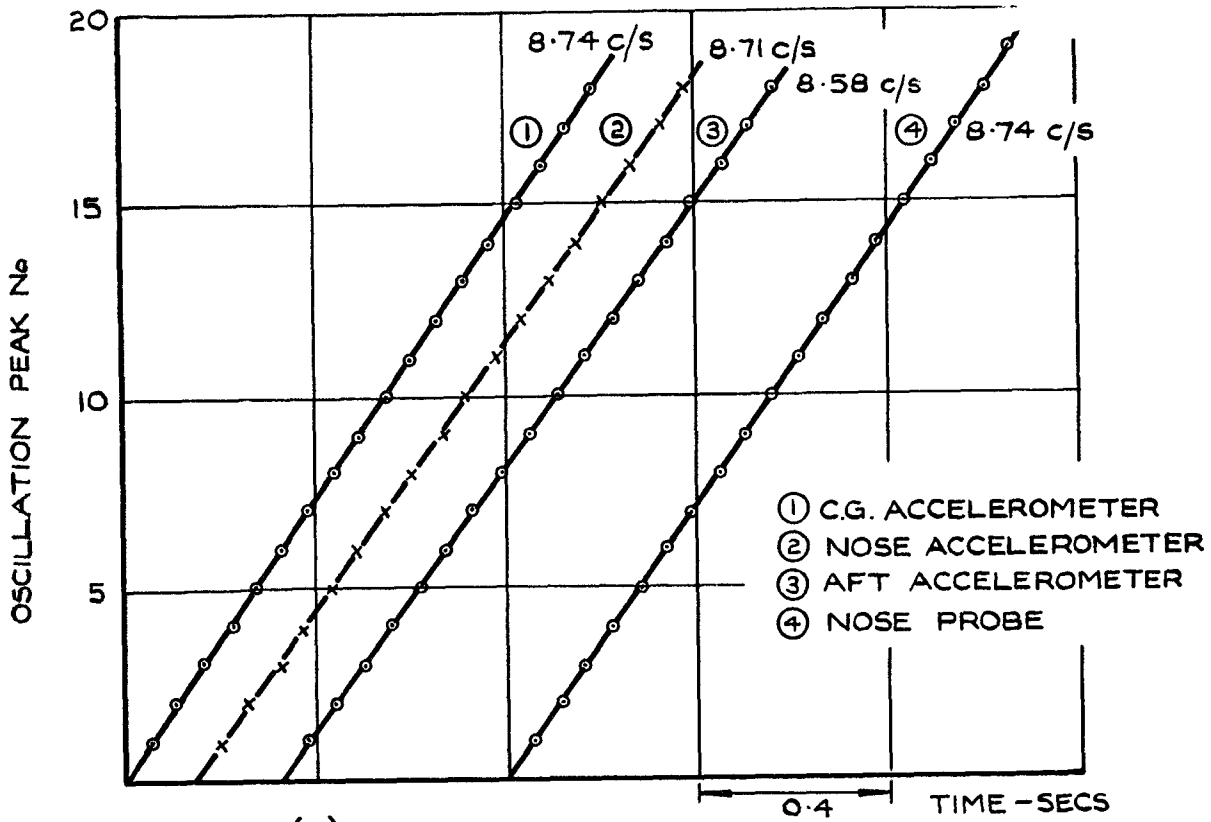
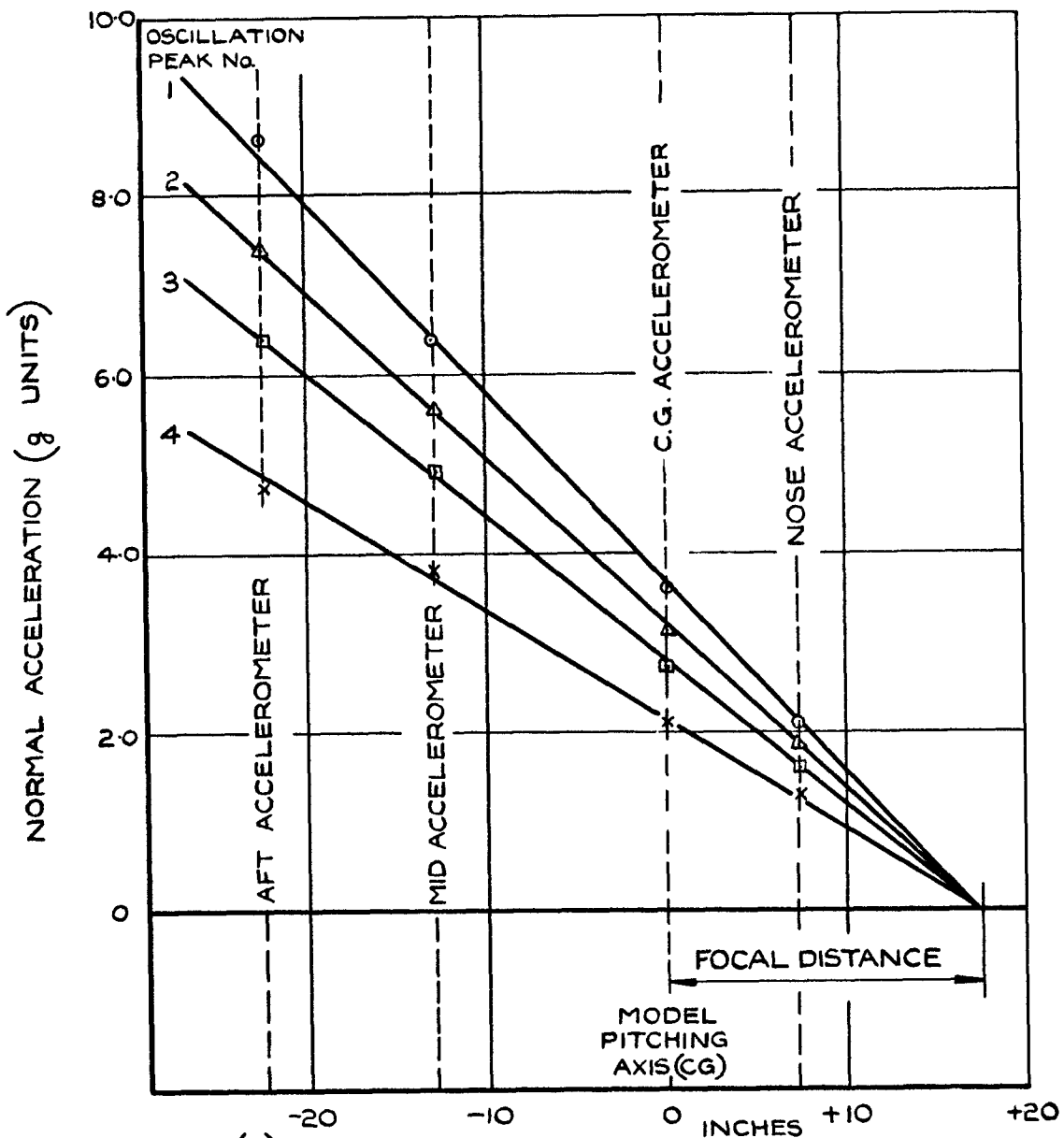

FIG.5. PORTION OF TELEMETRY RECORD



(a) DETERMINATION OF FREQUENCY.



(b) DETERMINATION OF FOCAL POINT.

FIG. 6.(a & b). TYPICAL ANALYSIS OF ONE OSCILLATION ($M=1.168$).

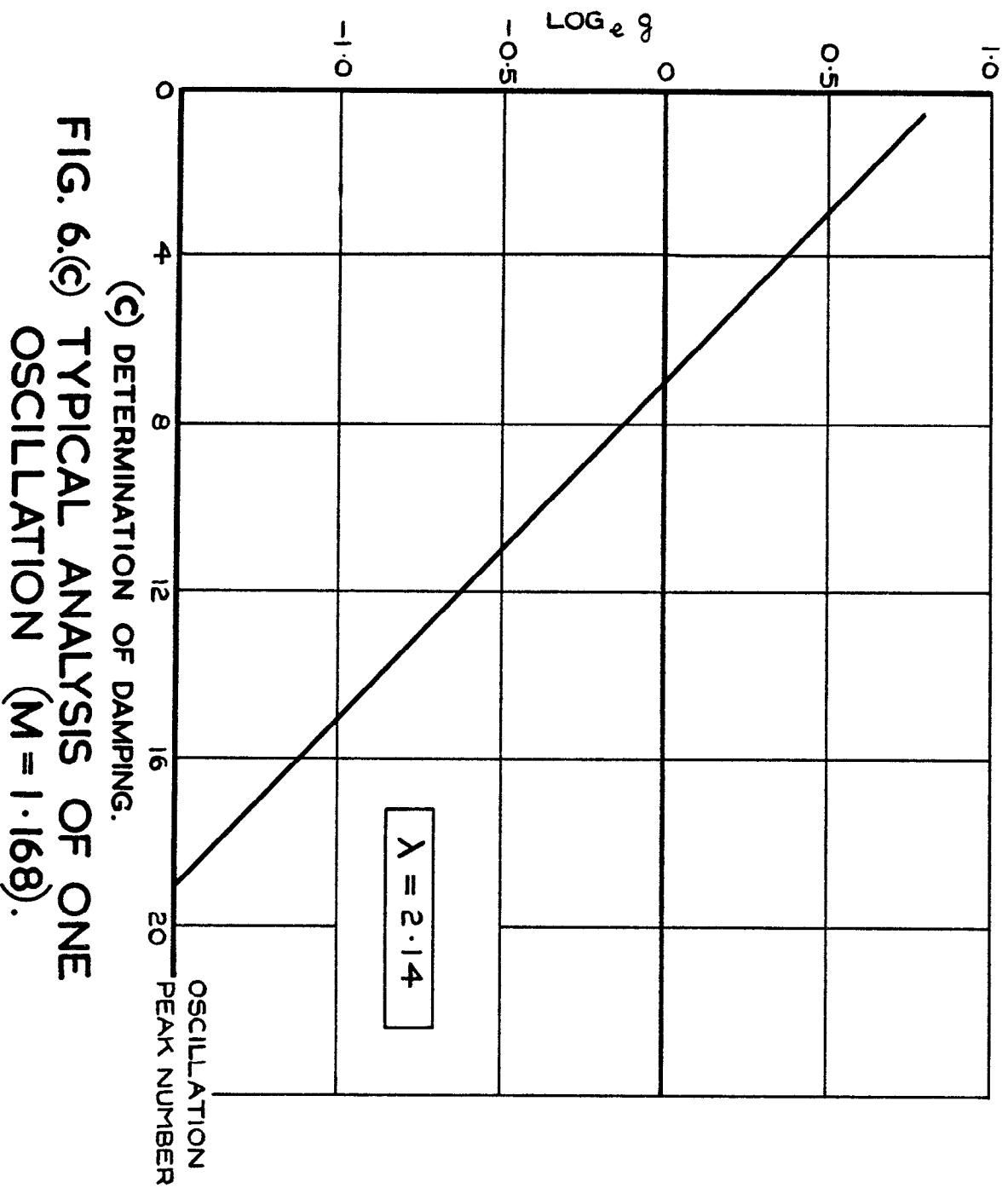
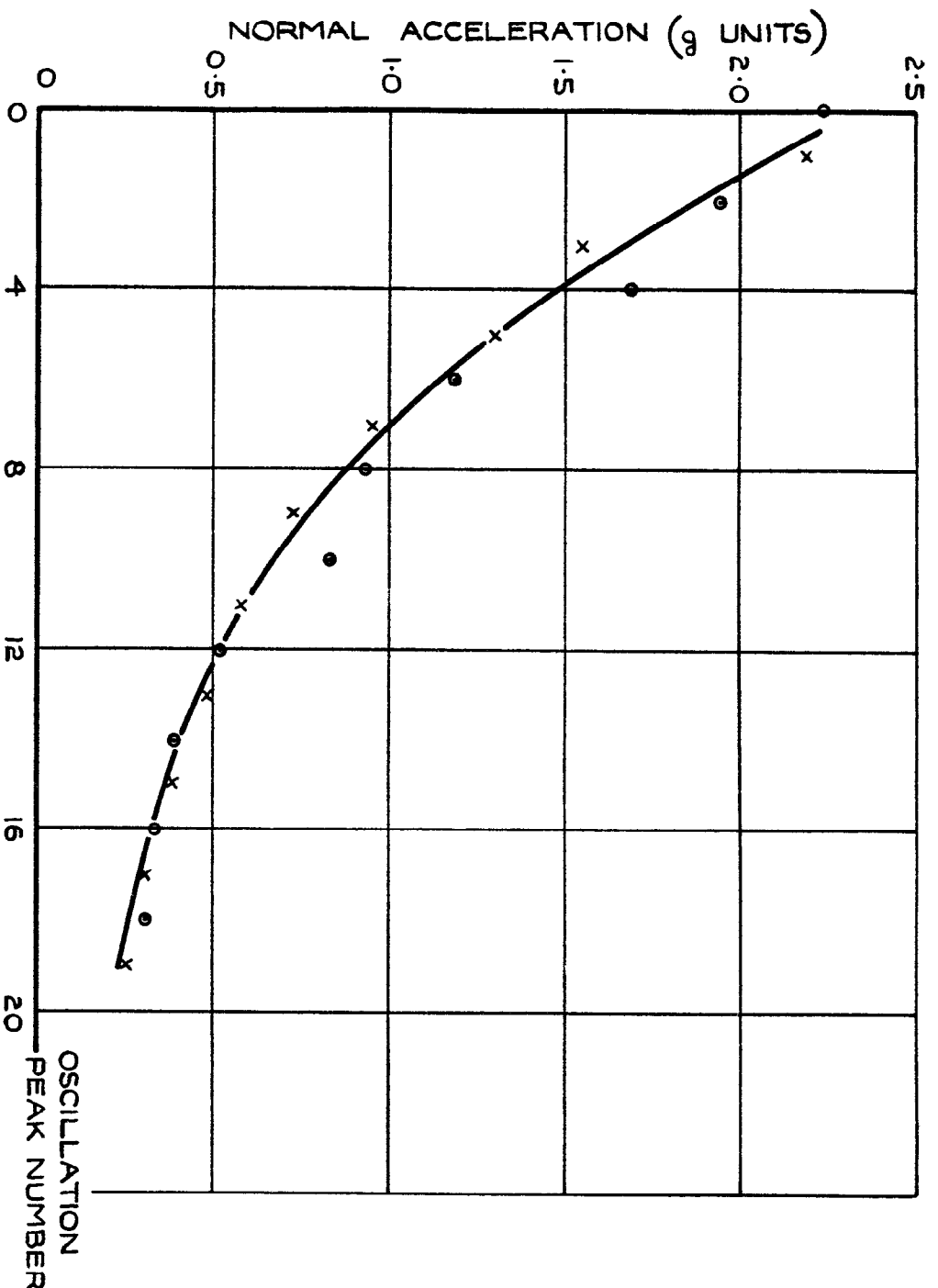

(c) DETERMINATION OF DAMPING.
 FIG. 6.(c) TYPICAL ANALYSIS OF ONE
 OSCILLATION ($M = 1.168$).

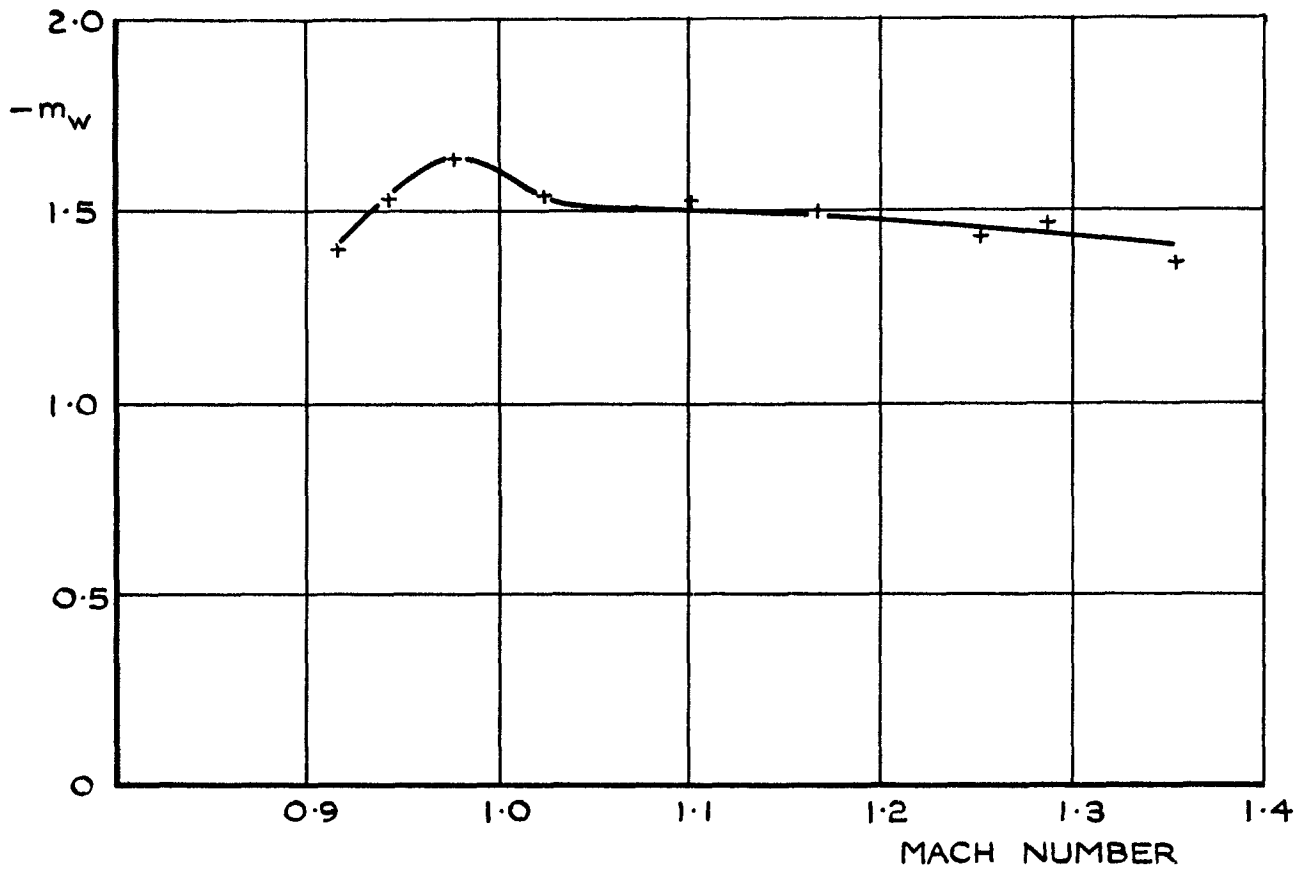

FIG. 7. VARIATION OF m_w WITH MACH NUMBER.

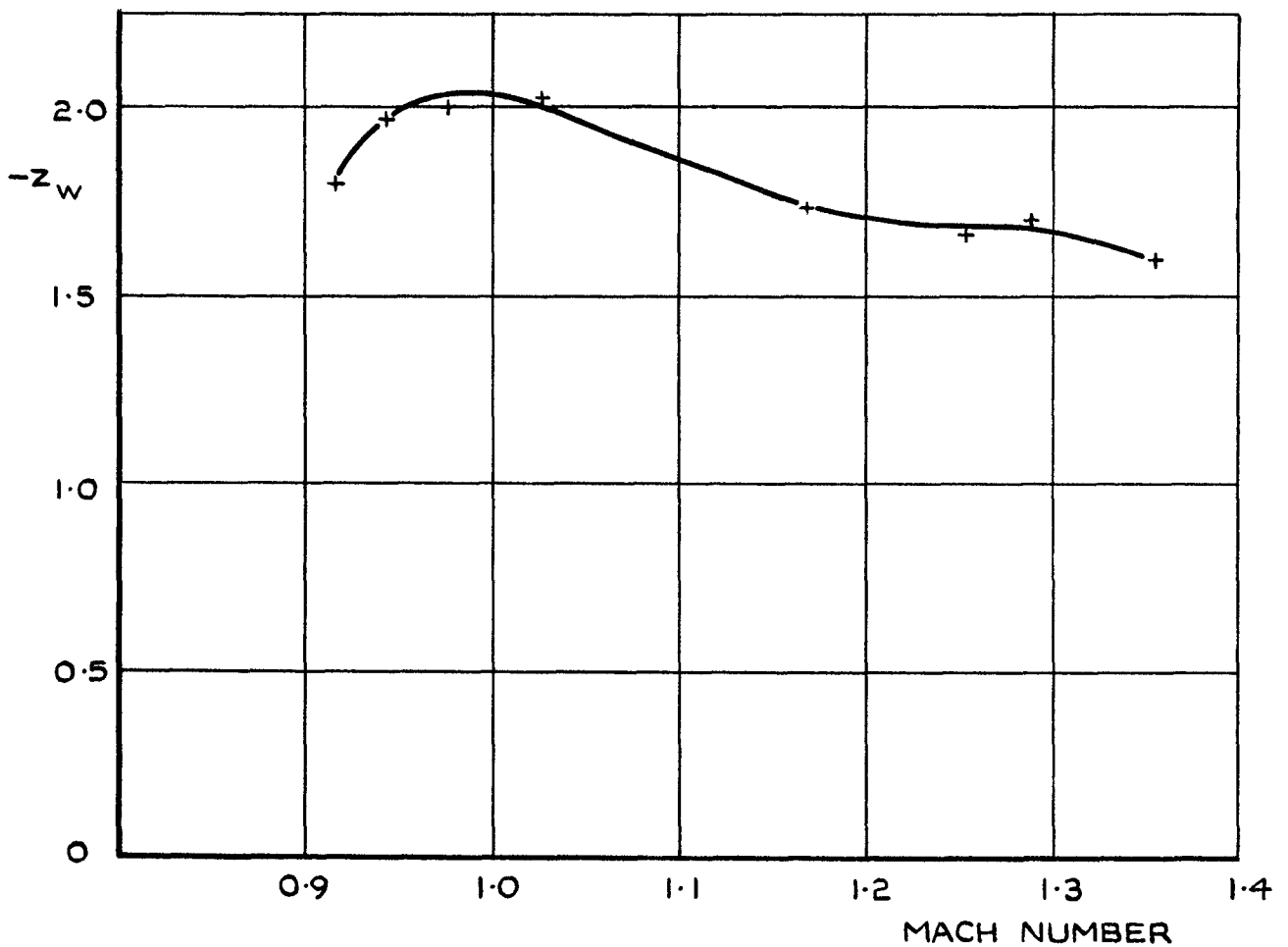

FIG. 8. VARIATION OF z_w WITH MACH NUMBER.

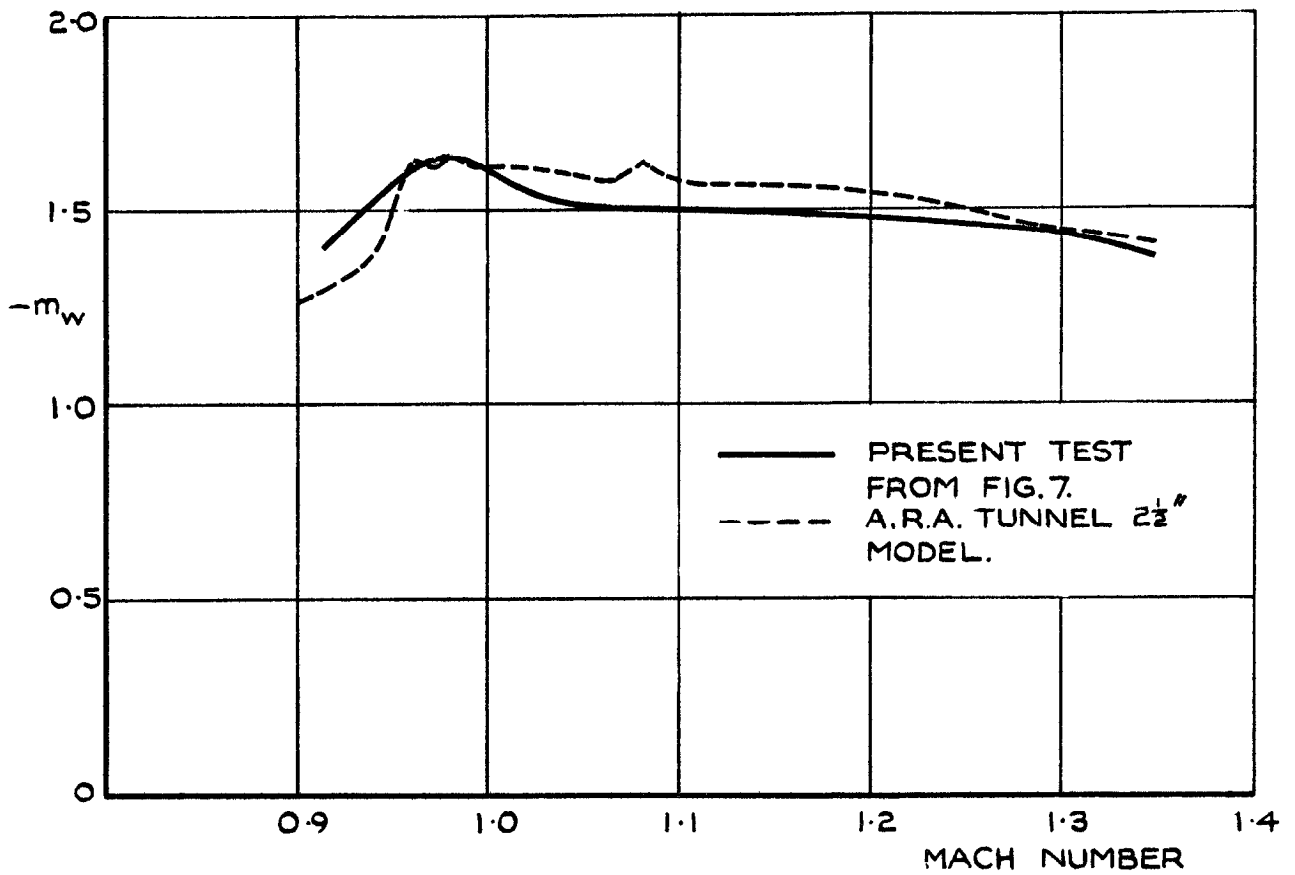

FIG. 9. FREE-FLIGHT/TUNNEL COMPARISON OF m_w

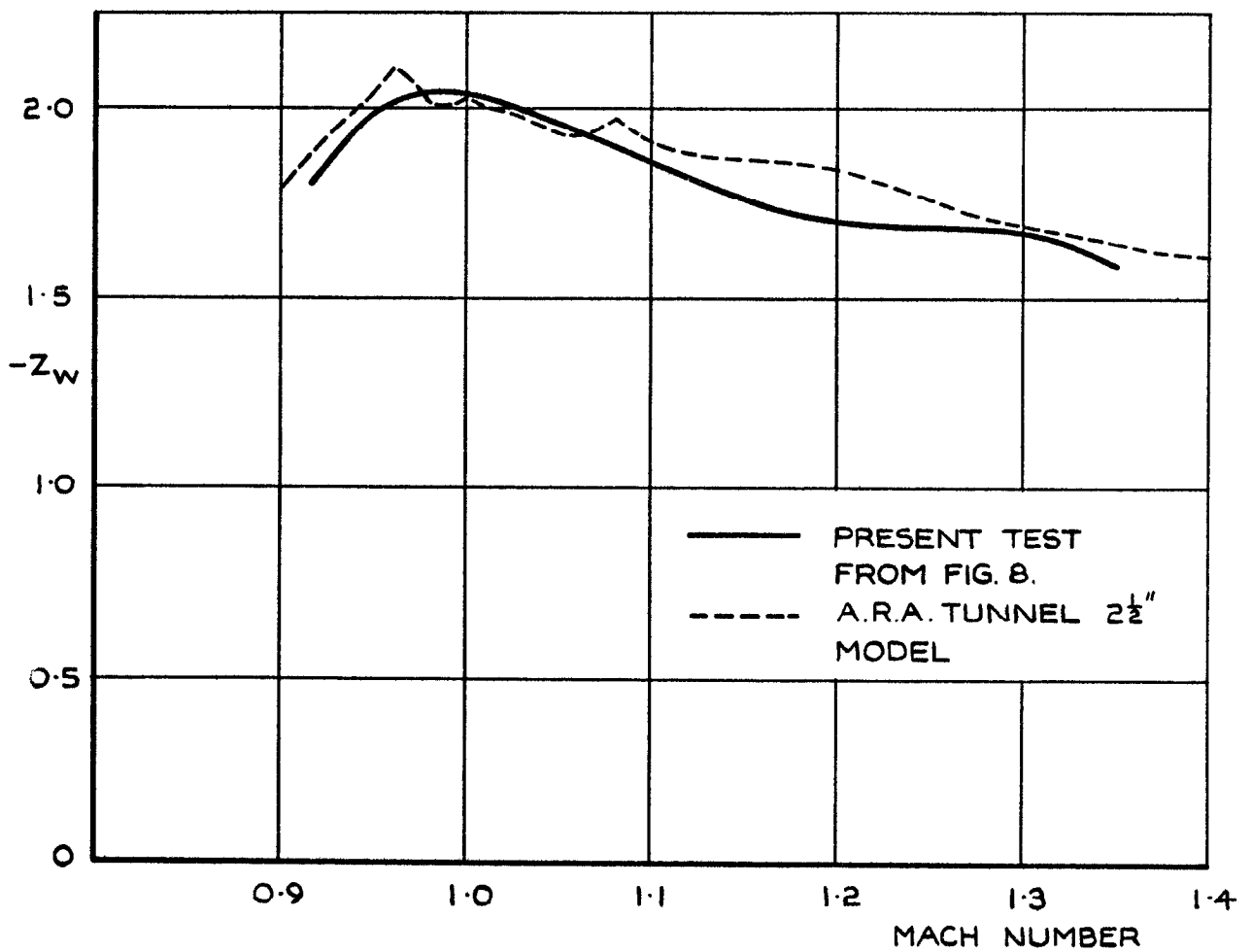

FIG. 10. FREE-FLIGHT/TUNNEL COMPARISON OF z_w

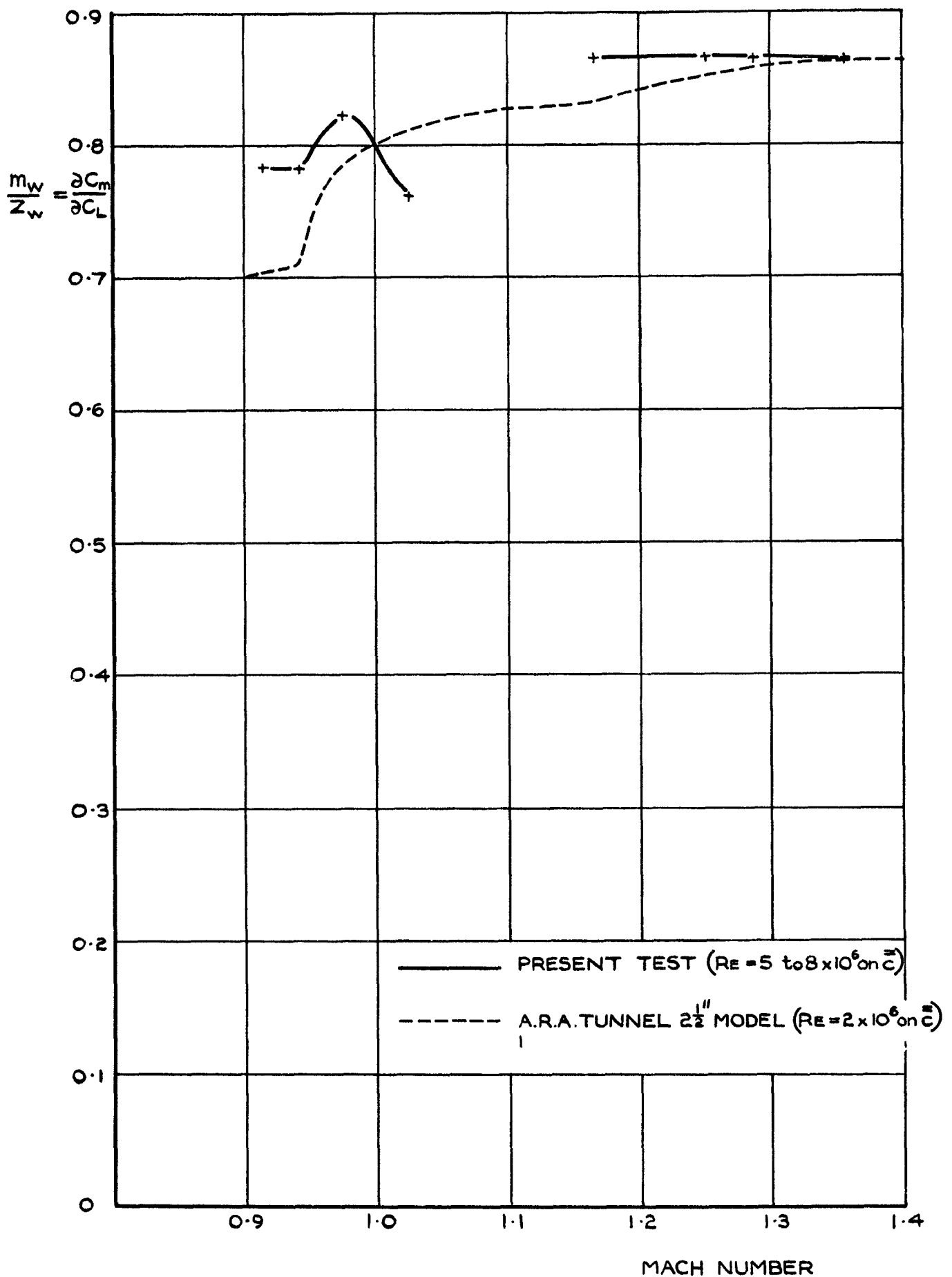

FIG. II. FREE-FLIGHT / TUNNEL COMPARISON OF
 MANOEUVRE MARGIN $\frac{\partial C_m}{\partial C_L}$

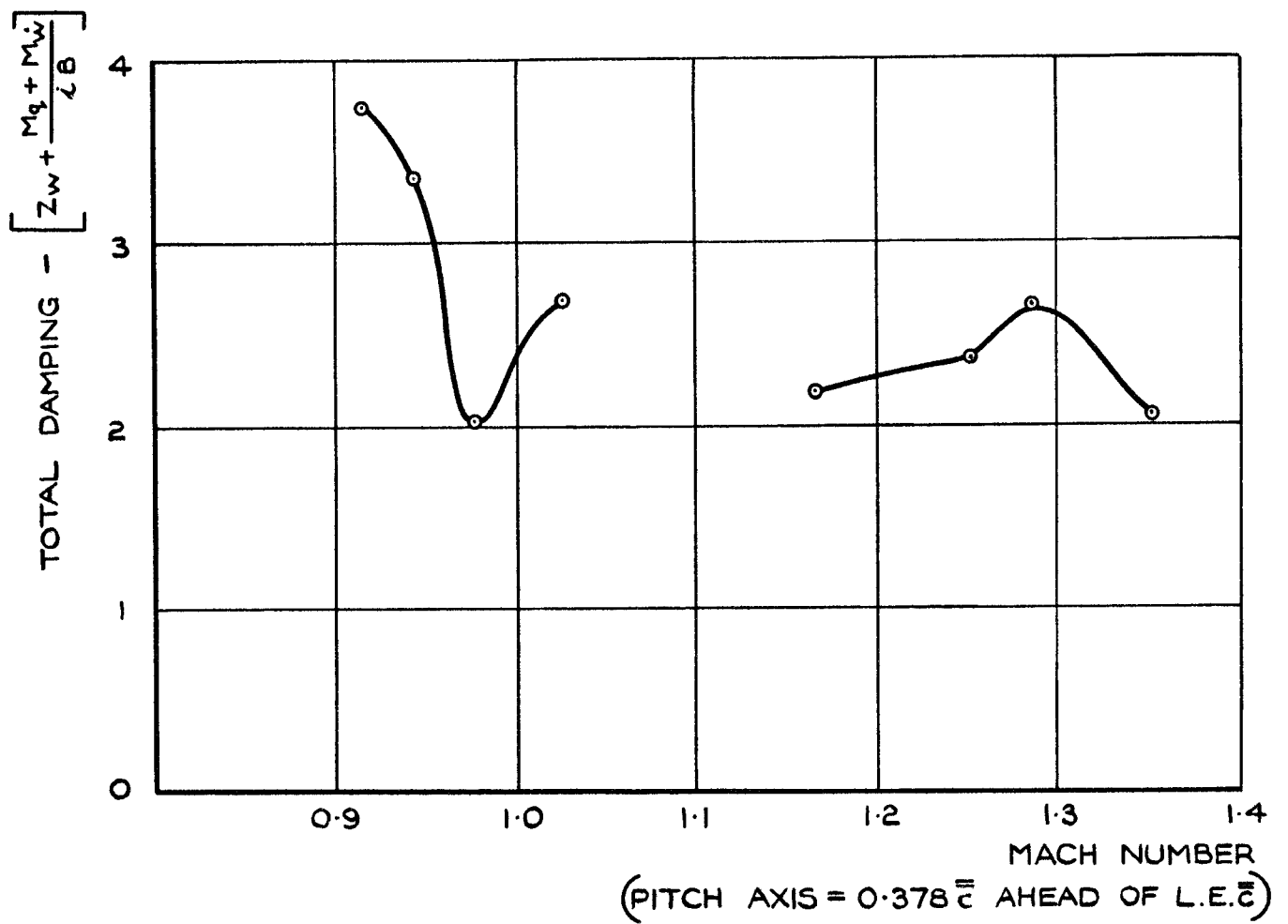

FIG. 12. TOTAL PITCH-DAMPING.

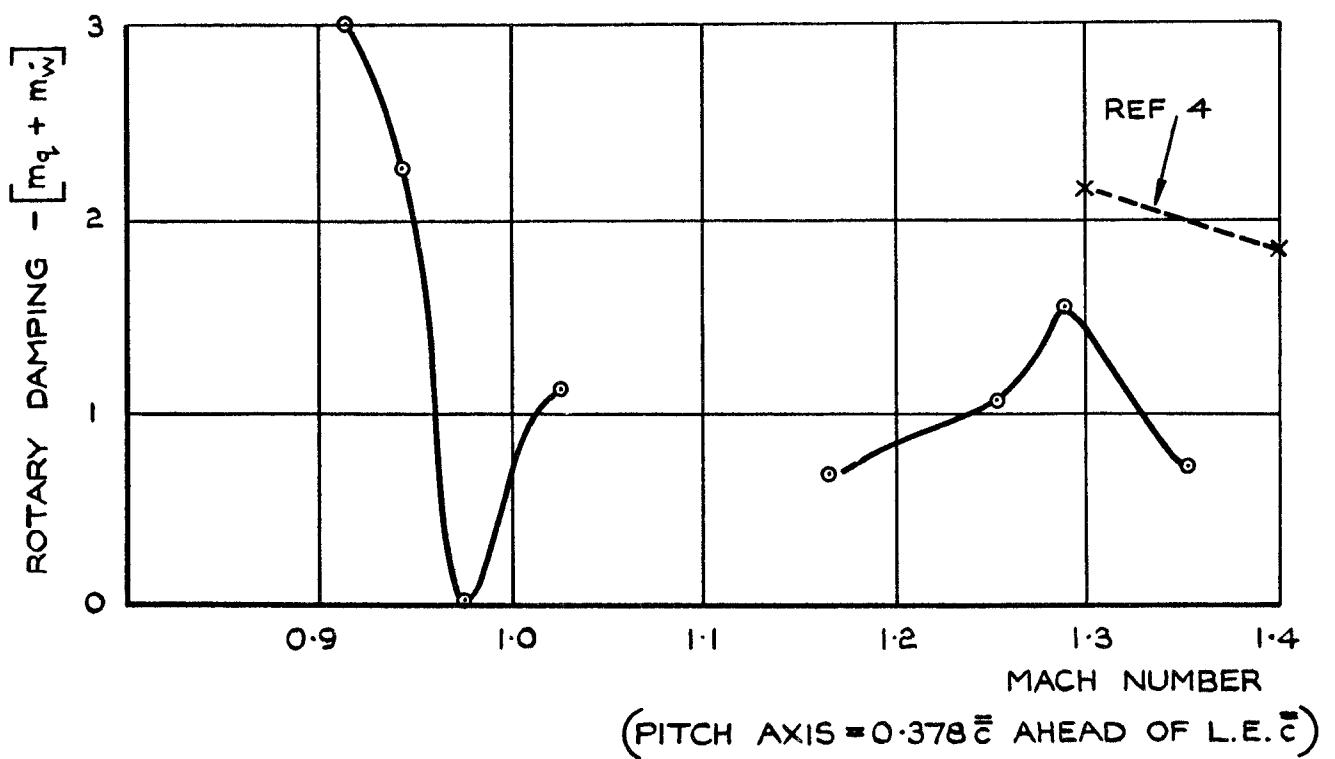

FIG. 13. ROTARY PITCH-DAMPING.

A.R.C. C.P. No. 648

533.6.071.33/.4:
533.6.013.412:
533.6.013.423:
533.6.011.35:
533.6.055

FREE-FLIGHT MEASUREMENTS OF THE DYNAMIC LONGITUDINAL-STABILITY
CHARACTERISTICS OF A WIND TUNNEL INTERFERENCE MODEL (M = 0.92 TO 1.35).
Greenwood, G.H. November, 1961.

The dynamic longitudinal-stability characteristics of a standard
wind tunnel interference model have been investigated in free flight
over a Mach number range of 0.92 to 1.35.

Measurements of lift-curve slope and manoeuvre margin were
obtained, and are compared with results from transonic-tunnel tests under
low blockage conditions.

UNCLASSIFIED

(Over)

A.R.C. C.P. No. 648

533.6.071.33/.4:
533.6.013.412:
533.6.013.423:
533.6.011.35:
533.6.055

FREE-FLIGHT MEASUREMENTS OF THE DYNAMIC LONGITUDINAL-STABILITY
CHARACTERISTICS OF A WIND TUNNEL INTERFERENCE MODEL (M = 0.92 TO 1.35).
Greenwood, G.H. November, 1961.

The dynamic longitudinal-stability characteristics of a standard
wind tunnel interference model have been investigated in free flight
over a Mach number range of 0.92 to 1.35.

Measurements of lift-curve slope and manoeuvre margin were
obtained, and are compared with results from transonic-tunnel tests under
low blockage conditions.

(Over)

A.R.C. C.P. No. 648

533.6.071.33/.4:
533.6.013.412:
533.6.013.423:
533.6.011.35:
533.6.055

FREE-FLIGHT MEASUREMENTS OF THE DYNAMIC LONGITUDINAL-STABILITY
CHARACTERISTICS OF A WIND TUNNEL INTERFERENCE MODEL (M = 0.92 TO 1.35).
Greenwood, G.H. November, 1961.

The dynamic longitudinal-stability characteristics of a standard
wind tunnel interference model have been investigated in free flight
over a Mach number range of 0.92 to 1.35.

Measurements of lift-curve slope and manoeuvre margin were
obtained, and are compared with results from transonic-tunnel tests under
low blockage conditions.

(Over)

The analysis was extended to obtain damping derivatives to allow comparison to be made with possible future dynamic tests in wind tunnels on the standard shape.

The analysis was extended to obtain damping derivatives to allow comparison to be made with possible future dynamic tests in wind tunnels on the standard shape.

The analysis was extended to obtain damping derivatives to allow comparison to be made with possible future dynamic tests in wind tunnels on the standard shape.

© *Crown Copyright 1963*

Published by
HER MAJESTY'S STATIONERY OFFICE

To be purchased from
York House, Kingsway, London W.C.2
423 Oxford Street, London W.1
13A Castle Street, Edinburgh 2
109 St. Mary Street, Cardiff
39 King Street, Manchester 2
50 Fairfax Street, Bristol 1
35 Smallbrook, Ringway, Birmingham 5
80 Chichester Street, Belfast 1
or through any bookseller

Printed in England