

C.P. No. 431
(18,877)
A.R.C. Technical Report

LIBRARY
ROYAL AIRCRAFT ESTABLISHMENT
BEDFORD.

C.P. No. 431
(18,877)
A.R.C. Technical Report



MINISTRY OF SUPPLY

AERONAUTICAL RESEARCH COUNCIL

CURRENT PAPERS

The Effect of Axial Spacing
on the Surge Characteristics of
Two Mismatched Axial Compressor
Stages

by

R. C. Turner

LONDON: HER MAJESTY'S STATIONERY OFFICE

1959

Price 4s. 6d. net

The effect of axial spacing on the surge characteristics of two mismatched axial compressor stages

- by -

R. C. Turner

SUMMARY

This Report describes an investigation into two of the major factors governing the surge of multistage axial compressors - the mismatching of the stages and the spacing between them. The purpose is to contribute to a fundamental understanding of surging.

Two highly mismatched stages were tested at five interstage spacings over a wide range of flow coefficient. The results were compared with those of separate tests on each stage. It was found that there was considerable mutual interference as regards the surge behaviour, and the aerodynamic characteristics generally were also affected. In particular, at the lower spacings, the second stage considerably delayed the surge of the first.

These results have important implications, in the understanding of the mismatched operation of a single multistage compressor and also the operation of two compressors in series, as in a double compound engine.

CONTENTS

	<u>Page</u>
1.0 Introduction	4
2.0 Description of apparatus	5
2.1 The compressor	5
2.2 Instrumentation	5
3.0 Test technique	6
3.1 General	6
3.2 Blading arrangements	6
4.0 Test results	7
4.1 General	7
4.2 Characteristics	8
4.3 Variation of surge flow coefficients	9
5.0 Discussion	10
5.1 The rotating stall cell	10
5.2 Discontinuities	11
5.3 Implications of the results	11
6.0 Conclusions	11
Notation	13
References	14
Appendix - Blade design details	15

ILLUSTRATIONS

<u>Fig. No.</u>	<u>Title</u>
1	Assembly of compressor
2	Leading dimensions of test rig
3	Arrangement of stages for each test
4	Characteristics - Tests 'A' and 'B'
5	Characteristics - Test 'C'
6	Characteristics - Test 'D'
7	Characteristics - Test 'E'
8	Characteristics - Test 'F'
9	Characteristics - Test 'G'
10	Characteristics of Stage 1
11	Characteristics of Stage 2
12	Characteristics of Stages 1 and 2 in series
13	V_a/U at surge and un surge related to interstage spacing
14	Stall cell propagation

1.0 Introduction

Consider a conventional multistage axial flow compressor operating in a sub-design mismatched condition. If the flow is reduced while the speed is kept constant, the first stages will eventually begin to act inefficiently, probably producing comparatively slow pulsations of pressure and flow, which can be detected by suitable instruments. The final stages however, will still be acting efficiently. In conventional terms, the first stages are said to be "stalled", this condition arising from the low flow coefficients in these stages, and being analogous to the high loss operation of a cascade at high incidences. Further reduction of flow will result in a major discontinuity in the overall characteristics of the compressor, accompanied by considerable rise in noise level. This is usually described as the "surge" of the whole compressor.

At this point, a difficulty of definition arises. If a single stage is operated at a gradually reducing flow coefficient, it may or may not produce a major discontinuity in its aerodynamic characteristics; it may or may not give a sudden change in noise level; it may or may not produce fluctuations in the flow; but it will at some point begin to perform inefficiently. According to the conventional definitions noted above, the operation could be described as "stalled" or "surged", depending on the degree of these phenomena and the preconceptions of the observer.

In the author's opinion, "stall" is best confined to its particular use in the description of cascade operation, while "surge" should be used to cover any abnormal operation of a stage or series of stages, where the abnormal operation is distinguishable from normal operation by one or more of several important characteristics; it may or may not be oscillatory in nature. This definition of "surge" is used in Reference 1, and will be used in the remainder of this Report.

Returning to the mismatched operation of a compressor, it seemed highly probable that the surge of the whole compressor was a function of the mutual interaction between the surged and unsurged stages; that the unsurged stages would modify the surge of the remaining stages; and that the axial spacing between the stages was an important determinant of these effects. Until now, however, there has been little or no information on this subject, on either the theoretical or the experimental sides. In the absence of any experimental background, the difficulties in the way of a theoretical approach are formidable, and the present tests were initiated as an essential step in the understanding of these phenomena.

Two stages with widely different aerodynamic characteristics were tested in the N.G.T.E. 106 compressor, separately and in series. In the latter case, the tests were performed with five axial spacings between the stages; the stages were highly mismatched, since in the 106 compressor the same flow coefficient is imposed on all stages.

It will be appreciated that the tests were an intentional exaggeration of the conditions prevailing in a conventional compressor. The mismatching between adjacent stages was much more severe and the axial spacing variation much larger than that usually encountered. While it is true that mismatching in a conventional compressor usually occurs by the imposition of different flow coefficients on similar stages, it is not thought that this is significant in assessing the value of the present tests.

2.0 Description of apparatus

2.1 The compressor

The 106 compressor is described in Reference 2. It is a low speed, multistage machine of constant annulus dimensions and a diameter ratio of 0.75. The blade height is 2.5 in. and the mean diameter is 17.5 in. At the running speed of 1500 rev/min, the mean blade speed is 114.5 ft/sec and the blade Reynolds number based on this speed is 0.65×10^5 . The blade chord is approximately 1.1 in. Any number of stages up to eight can be employed and the interstage spacing can be varied within limits.

In the present tests, the blades were of medium stagger free vortex design with 50 per cent reaction at the mean diameter. Design details of Stage 1 are given in Appendix I. For Stage 2, the staggers of the rotor and stator blades were numerically increased by 15° . When Stage 2 was tested alone, the inlet guide vanes were left at the design stagger and in the same relative axial position as for the single stage test of Stage 1.

Figure 1 shows the general arrangement of the compressor assembled with six stages, and Figure 2 shows the main dimensions of the associated ducting and throttle. Further details of the blading arrangements in these tests are given in Section 3.2.

2.2 Instrumentation

Total pressures

Two five-point pitot combs spaced 180° apart were installed after each stage and at the outlet end of the compressor. Figure 3 shows the axial position of the pitot combs for the various stage arrangements tested. The corresponding tubes in the two combs were connected together and to fluid manometer columns. The combs were yawed to give maximum readings (which occurred nearly simultaneously on all the tubes) at a flow coefficient slightly higher than that for which surge was first noted. The inlet total pressure was taken as atmospheric, an allowance being made for the pressure loss across the inlet gauze where this was required for exact assessment of the stage pressure rises.

Mass Flow

Four static tubes placed in the inlet annulus were connected to a manifold and thence to a Betz manometer. The readings had previously been calibrated for mass flow against a standard orifice in outlet ducting provided on a different test bed. On the present bed there was not sufficient ducting to allow the installation of a standard orifice; but the ducting before the throttle was reduced in diameter and the pitot-static difference in it was measured on another Betz manometer. This difference was plotted for each test against the inlet static depression; it was found that the relationship was linear so long as the compressor was unsurged; compressor surge was found to alter the relationship considerably, presumably by disturbing the inlet conditions. Surged flows were estimated by assuming the outlet pitot-static difference to be unaffected and using the linear relationship mentioned above.

Other measurements

The speed was measured by means of a Hasler hand tachometer; and the inlet temperature by a mercury-in-glass thermometer.

3.0 Test technique

3.1 General

It was found that reduction of the flow coefficient eventually produced audible pulsations, sometimes accompanied by discontinuities in the pressure rise coefficient. No other major abnormality in the flow was detected. The general definition of surge in Section 1.0 was therefore restricted to mean "operation with audible pulsations". In some tests, a rapid pulsation preceded a slower pulsation, which usually persisted down to zero flow. Surge was therefore divided into two categories - "rapid pulse" and "slow pulse", these providing practical criteria for test purposes. It was not possible to distinguish, in the two stage tests, between the surges of the individual stages; they were assumed to surge simultaneously. This assumption appears to be borne out by examination of the characteristics (Section 4.2).

The flow reading at the start of a discontinuity and a complete set of readings at its finish were always noted. All major changes of noise were noted, and two test runs were made with each blading arrangement.

3.2 Blading arrangements

A normal six stage assembly of the compressor is shown in Figure 1; this forms the basis of the blading arrangements. For all of the present tests, the inlet guide blades were left at their design stagger. For the first two tests, (designated 'A' and 'B') one stage only was tested, in the first stage position of Figure 1; first with the rotor and stator blades at their design stagger (Test 'A'); and secondly with the rotor and stator blades set at a stagger value 15° numerically above design (Test 'B'). For the remaining tests, the blades of Stage 1 were maintained at their design settings, while those of Stage 2 were set 15° higher, and were spaced successively in the positions corresponding to Stages 2 to 6 of the six stage build of Figure 1; these tests were designated 'C' to 'G' respectively. Figures 2 and 3 and the following table summarise these arrangements.

Test designation	Interstage spacing	Stagger Settings				
		Stage 1			Stage 2	
		I.G.	Rotor	Stator	Rotor	Stator
A	Single Stage	Design	Design	Design	-	-
B	Single Stage	Design	Design + 15	Design + 15	-	-
C	1.8 in.	Design	Design	Design	Design + 15	Design + 15
D	5.4 in.	Design	Design	Design	Design + 15	Design + 15
E	9.0 in.	Design	Design	Design	Design + 15	Design + 15
F	12.6 in.	Design	Design	Design	Design + 15	Design + 15
G	16.2 in.	Design	Design	Design	Design + 15	Design + 15

The interstage spacing is taken as the axial distance between the centre plane of Stage 1 stator blades and the centre plane of Stage 2 rotor blades.

4.0 Test results

4.1 General

The total pressure rise coefficient versus flow coefficient characteristics for each test are plotted in Figures 4 to 9. These characteristics include the pressure loss at inlet. Different symbols are used for each test run and those points taken at increasing flow coefficients are also indicated. The surge and unurge flow coefficients for each test are indicated at the bottom of the figures and the mean values for the two runs are also marked on the curves. Where a flow discontinuity exists at surge or unurge, the flow coefficients at its start and finish are indicated, the starting values being indicated by dotted lines and the finishing values by full lines.

Subjective evaluations of the noise omission are also indicated in Figures 4 to 9, the discontinuities being shown by shaded areas, for both increasing and decreasing flow coefficients. The rapid pulse was always rather difficult to hear, and was recognised only with practice; the frequency was estimated at about 10 c.p.s. (at 1500 rev/min). The slow pulse was estimated at about 4 c.p.s., and was less difficult to recognise, although it tended to vary considerably in intensity with flow coefficient; a fluctuation of the same frequency could sometimes be detected on the manometer columns. Both slow and rapid pulse frequencies seemed fairly constant both from test to test and with respect to flow coefficient. In Tests 'E', 'F', and 'G', for some ranges of flow coefficient, random fluctuations of noise intensity and quality were superimposed

on the slow pulse, with sympathetic variations in the manometer readings. In a typical case, successive peaks occurred at intervals of about five seconds.

In Figures 4 to 9, smooth curves are drawn through the test points. Generally, in the unsurged regions, there is less scatter of the points than in the surged regions. In Figures 10 to 12 the curves are grouped for each stage, and for the two stages in series, allowance being made, to facilitate comparison, for the pressure loss across the inlet of the compressor. Changes in detail of the shapes of the curves after the second (slow pulse) surge, especially towards zero flow, are of minor importance, not only because the present interest is mainly restricted to the actual points of surge and unurge, but also because the precise significance of the pitot comb readings in a pulsating flow is not known. Figures 10 and 11 also show the theoretical mean diameter characteristics of the stages, based on the methods of References 3 and 4, and using a work-done factor of 0.86. The theoretical stall points as defined in Reference 3, are also shown.

4.2 Characteristics

Test A, Figures 4 and 10

Surge is seen to occur well past the peak of the curve, and at a lower flow than the theoretical mean diameter stall. There are appreciable discontinuities at surge and unurge, the end of the unurge discontinuity being near the peak. No rapid pulse surge was observed in this test.

Test B, Figures 4 and 11

Here again, surge occurs past the peak of the curve, but at about the flow coefficient of the theoretical stall. This theoretical value is the mean of the mean diameter values for the rotor and stator blade rows; unlike the design condition of Test 'A', the rotor and stator blades are subjected to different theoretical mean diameter conditions because of the fact that the inlet guide blades were unchanged while the rotor and stator blades were restaggered by 15° . No rapid pulse surge was observed in this test.

Test 'C', Figures 5, 10, 11 and 12

The surge flow coefficient of Stage 1 is seen to be much reduced below its "single stage" value (Test 'A'), its value being in fact, that of Stage 2 when tested alone (Test 'D'). There are considerable discontinuities at surge and unurge, these resulting in "hysteresis" loops for both Stages 1 and 2. The characteristic of Stage 2 does not peak, but shows a rather sudden change of slope at $V_a/U = 0.45$. No rapid pulse surge was observed. At a flow coefficient of 0.12, the slow pulse disappeared and gave way to a smoother sound. There was no apparent corresponding change in the characteristics. No similar effect was noted in the succeeding tests, where the slow pulse continued down to zero flow.

Test 'D', Figures 6, 10, 11, and 12

This is the smallest spacing at which the rapid pulse surge was noted, occurring at a flow coefficient of about 0.45. Marked discontinuities are seen in the characteristics at both the rapid pulse and slow pulse surge

points, the latter being accompanied by a large drop in overall pressure rise.

Test 'E', Figures 7, 10, 11 and 12

There were no noticeable flow discontinuities at surge or unurge in this test, either for the rapid pulse or for the slow pulse conditions; the slow pulse surge occurred at the peaks of the overall and Stage 2 characteristics. There were, however, minor discontinuities (noticed as appreciable changes in flow for infinitesimal changes in throttle settings) unaccompanied by noticeable changes in noise. Slow random fluctuations of noise, as described in Section 4.1, were observed at flow coefficients below the slow pulse surge. The characteristic of Stage 2 is seen to exhibit a well defined peak (absent in Tests 'C' and 'D'). Figure 11 shows its value to be smaller than that of the corresponding single stage test (Test 'B'). This is probably partly due to phenomena connected with the rapid pulse surge; but it is to be expected that a second stage may have a lower work-done factor than a first stage.

Test 'F', Figures 8, 10, 11 and 12

Although there were no flow discontinuities noted during the test, there is seen to be a considerable scatter of points in the region of the slow pulse surge point, which occurs near the peak of the Stage 2 characteristic; in fact the curve for Stage 1 as drawn shows a "break" at this point. The slow random fluctuations of noise and pressure again occurred at low flow coefficients.

Test 'G', Figures 9, 10, 11 and 12

In this test, rapid pulse surge was absent; small discontinuities occurred at surge and unurge. The slow random fluctuations at low flows were again noted. The peak seen in the characteristic of Stage 2 in Test 'F' has become much flatter.

General remarks

Examination of Figures 4 to 12 shows that the characteristic of Stage 1 is affected comparatively little in general shape by the presence of Stage 2 at any spacing, while that of Stage 2 is greatly changed by the presence of Stage 1, and is sensitive to spacing. Even at the highest spacing (Test 'C'), the characteristics of both stages are different from their single stage conformations, and there is no evidence of independent operation; for instance, at the single stage surge flow coefficient of Stage 2, the Stage 2 characteristic in Test 'G' is quite continuous.

4.3 Variation of surge flow coefficients

In Figure 13, the flow coefficients at surge and unurge have been related to the interstage spacing for both the rapid pulse and slow pulse surges. Discontinuities are also indicated. Also shown are the corresponding flows in the two stages when tested individually (Tests 'A' and 'B'). The figure emphasises several points of considerable interest:-

- (a) At the lowest interstage spacing slow pulse surge (only) occurs at approximately the individual surge flow coefficient of the second stage. At the highest spacing it occurs at that of the first stage.

- (b) Between these two extremes there is a gradual variation of slow pulse surge flow coefficient; but the slow pulse surge is preceded by the rapid pulse surge, which for the higher spacings occurs at approximately the single stage value of the first stage.
- (c) The slow and rapid pulse surge flow coefficients vary in a similar manner to those of the surge coefficients.
- (d) At the two lower interstage spacings, there are considerable discontinuities in flow coefficients at the slow pulse surge and surge. These disappear at the next two higher spacings; small discontinuities reappear at the highest spacing.
- (e) Discontinuities at the rapid pulse surge and surge flow coefficients are exhibited for the lower spacings only.

5.0 Discussion

The feature of outstanding importance in these tests is the suppression of the first stage surge by the second stage at the lowest spacing. This result is of great significance, and has not previously been demonstrated with any certainty. It is necessary therefore to consider its mechanism in some detail. This is done in Sections 5.1, 5.2, and 5.3. Section 5.4 discusses discontinuities, and Section 5.5 the wider implications of the results.

5.1 The rotating stall cell

Work on other compressors using hot wire techniques suggests that the surge observed in the present tests was caused by one or more regions of stalled flow extending partially or fully across the annulus but limited in circumferential extent and rotating at a fraction of the compressor speed, in the same direction as that of the rotor. The usually accepted qualitative explanation is the "blockage" theory. Considering a row of blades operating at an incidence near to the stalling value, one or several adjacent blades are supposed to stall. The local pressure loss in the stalled region (or "stall cell") interacting with the flow field about the rest of the blading results in a local reduction of flow through the stall cell. The stream lines approaching the region thus diverge about it as they approach the blading, the divergence causing a local increase of incidence on one side of the region and a local decrease on the other. Thus on one side the blades tend to stall and on the other to unstall; the net result is that the stall cell travels circumferentially round the blade row at an approximately uniform rate. Figure 14 illustrates the effect diagrammatically and shows that the direction of rotation of a stall cell is relatively the same for both rotor and stator rows.

In practice, more than one stall cell may develop around the annulus, all rotating at the same speed. Quantitative theoretical approaches to the general problem (e.g. References 7 and 8) while attempting to predict the speed and other characteristics of propagation have not yet so far predicted the number of cells in an annulus.

In the present tests, the change from the "rapid pulse" to the "slow pulse" condition may have been due to a change in the number of stall cells, a change in their speed of rotation or a combination of both these factors. A detailed flow examination (e.g. by using hot wire techniques) would be necessary in order to determine which explanation is correct.

5.2 Discontinuities

Since a discontinuity occurs with zero change in the throttle setting, both the start and finish should lie on the throttle characteristic corresponding to that setting. In general, throttle characteristics are of the parabolic form $\frac{\Delta P}{\frac{1}{2}\rho U^2} = K \left(\frac{V_a}{U} \right)^2$ where K is the function of the throttle setting if the blade velocity U is constant, and may be plotted on the compressor characteristic sheet. Now, considering the overall characteristic of Figure 5, a line joining the extremities of the "Va/U decreasing" discontinuity will cut the "Va/U = 0" at a positive value of $\Delta P / \frac{1}{2}\rho U^2$; thus the extremities could not lie on a single parabola through the region. The probable explanation is that when rotating stall cells are present, the throttle characteristic (which includes all ducting losses) referred to the pressure rise as measured in these tests, has a different form to that for steady flow for the same throttle setting.

The minor discontinuities noted in Test 'E' are probably due to small sudden changes in stall cell pattern. The larger discontinuities shown at low spacings (Figure 13) suggest that the change of flow pattern is more abrupt than at the higher spacings. In Reference 11, it is stated that a surge discontinuity is associated with the sudden inception of root to tip stall cells, i.e. covering the whole annulus width while a change into the surged condition is due to the gradual spread of the stall cells across the annulus from (say) root to tip.

5.3 Implications of the results

Considering the sub-design mismatched condition of a conventional compressor, the present tests show that stall cell formation in the first stages will be considerably influenced by the later stages. This influence will depend on the distances between the first and the later stages, on the working point of each stage relative to its surge point (i.e. the degree of mismatching) and probably on the slopes of the individual stage characteristics. Extending the argument further, these same factors will govern the surge of the whole compressor, assuming that the latter is a function (at present unknown) of stall cell propagation through the compressor. A quantitative theoretical basis will of course be required for the purpose of predicting these effects accurately.

A point of importance in some aircraft applications is in the operation of two compressors in series, as in a double compound engine. The results strongly suggest that under some conditions of operation, the surge lines of the compressors may be considerably different to those obtained on individual rig tests, especially when the axial inter-compressor spacing is small.

6.0 Conclusions

Two medium stagger free vortex stages were tested singly and in series, the second being of identical blading to the first, but re-staggered to give a considerably lower surge point flow. The axial interstage spacing was varied from 1.6 chords to 14.7 chords in five equal increments.

It was found that at the lowest spacing surge occurred at the single stage surge point flow of Stage 2, the surge of Stage 1 being completely suppressed until this flow was reached. At the highest spacing, surge occurred at the single stage surge point flow of Stage 1. At intermediate spacings, there was a continuous change of surge point flow between these extremes; but in addition, the normal surge was preceded by a less noticeable surge, characterised by a more rapid pulsation and a smaller effect on the stage characteristics.

At all interstage spacings, the stage characteristics were distorted from the shapes found in single stage tests, the effect being greater on Stage 2 than on Stage 1. It is thought that the surges in those tests were due to the presence of rotating stall cells.

Although the direct practical use of these tests is limited, since the spacings used are larger than those normally encountered, it is thought that they are significant in the understanding of the surge of mismatched multistage compressors; in particular they serve to emphasise the importance of the later stages.

Finally, the tests have a bearing on the operation of two compressors in series, as in a double compound engine, and suggest that there may be mutual interference between the two, especially as regards the surge condition.

ACKNOWLEDGMENTS

Acknowledgment is made to Miss H. P. Hughes and to Mr. R. A. Burrows for their part in the testing and analysis involved in this investigation.

NOTATION

U	=	blade speed at mean diameter
V _a	=	axial velocity
ΔP	=	total pressure rise
ρ	=	density
c	=	blade chord
s	=	blade pitch
t	=	blade maximum thickness
α	=	air angle measured from the axial direction
β	=	blade angle measured from the axial direction
θ	=	blade camber

Suffices

1	before rotor blade row
2	after rotor blade row
3	before stator blade row
4	after stator blade row

REFERENCES

<u>No.</u>	<u>Author(s)</u>	<u>Title etc.</u>
1	A. G. Smith and P. J. Fletcher	Observations on the surging of various low speed fans and compressors. A.R.C. 17,139, July, 1954.
2	R. A. Jeffs	Description of the low speed com- pressor No. 106. P. J. Report No. R.1198. A.R.C. 6842, April, 1946.
3	A. R. Howell	Fluid dynamics of axial compressors. Proc. I. Mech. E. Vol. 153. W.E. Issue 12, 1945.
4	A. D. S. Carter	The low speed performance of related aerofoils in cascade. A.R.C. C.P. No.29, September, 1949.
5	T. Iura and W. A. Rannie	Experimental investigations of propa- gating stall in axial-flow compressors. A.S.M.E. Paper 53-SA-69, July, 1953.
6	M. D. Wood, J. H. Morlock and E. K. Armstrong	Experimental investigation of the stall flow of a single stage axial compressor. A.R.C. 17,328, November, 1954.
7	W. R. Sears	A theory of "rotating stall" in axial- flow compressors. Graduate School of Aeronautical Engineering, Cornell University, January, 1953.
8	F. E. Marble	Propagation of stall in a com- pressor blade row. Journal of the Aeronautical Sciences, Vol. 22, No.8, August, 1955.
9	M. C. Huppert, E. L. Costilow and R. E. Budinger	Investigation of a ten stage sub- sonic axial flow research compressor: III - investigation of rotating stall, blade vibration and surge at low and intermediate compressor speeds. N.A.C.A. Research Memorandum RME53C19, May, 1953.
10	H. Pearson and T. Bowmer	Surging of axial compressors. Aeronautical Quarterly, Vol.1, November, 1949.
11	M. C. Huppert and W. C. Benser	Some stalling and surge phenomena in axial compressors. Journal of the Aeronautical Sciences, Vol. 20, No.12, December, 1953.

APPENDIX

Blade design details

The blades were of free vortex design (design flow coefficient = 0.667; 50 per cent reaction at mean diameter), with details as below. The section was C4 on circular arc camber lines; the blade height was 2.5 in. and the mean radius 8.75 in.

The rotor has fifty-eight blades and the stator sixty so that with blades of 1.14, 1.10, and 1.06 in. at root, mean, and tip respectively, the details are as follows:-

<u>Rotor</u>			
r/r_m	0.874	1.0	1.14
β_1	39.2	46.5	50.6
β_2	-3.5	15.6	32.0
θ	42.7	30.9	18.6
s/c	0.726	0.862	1.020
t/c	0.12	0.10	0.08
α_2	5.5	23.4	37.8
<u>Stator</u>			
r/r_m	0.860	1.0	1.125
β_3	52.0	46.1	42.2
β_4	18.6	15.9	14.0
θ	33.4	30.2	28.2
s/c	0.744	0.833	0.905
t/c	0.10	0.11	0.12
α_4	26.7	23.4	21.1
<u>Inlet Guides</u>			
r/r_m	0.86	1.0	1.125
β_3	0	0	0
β_4	-31.6	-28.2	-25.9
θ	31.6	28.2	25.9
s/c	0.744	0.833	0.905
t/c	0.10	0.11	0.12
α_4	26.7	23.4	21.1

FIG. 1

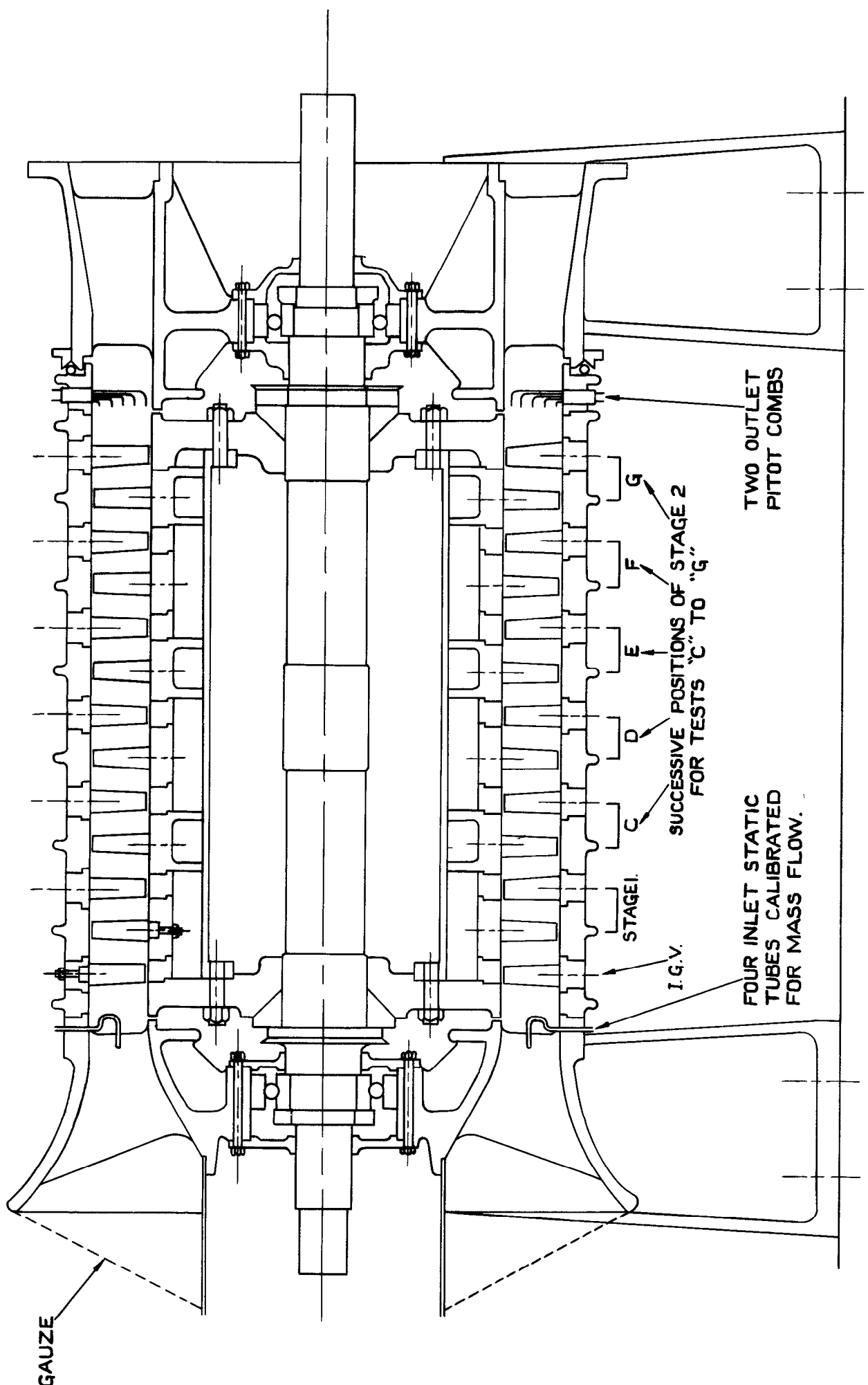

ASSEMBLY OF COMPRESSOR

FIG.2.

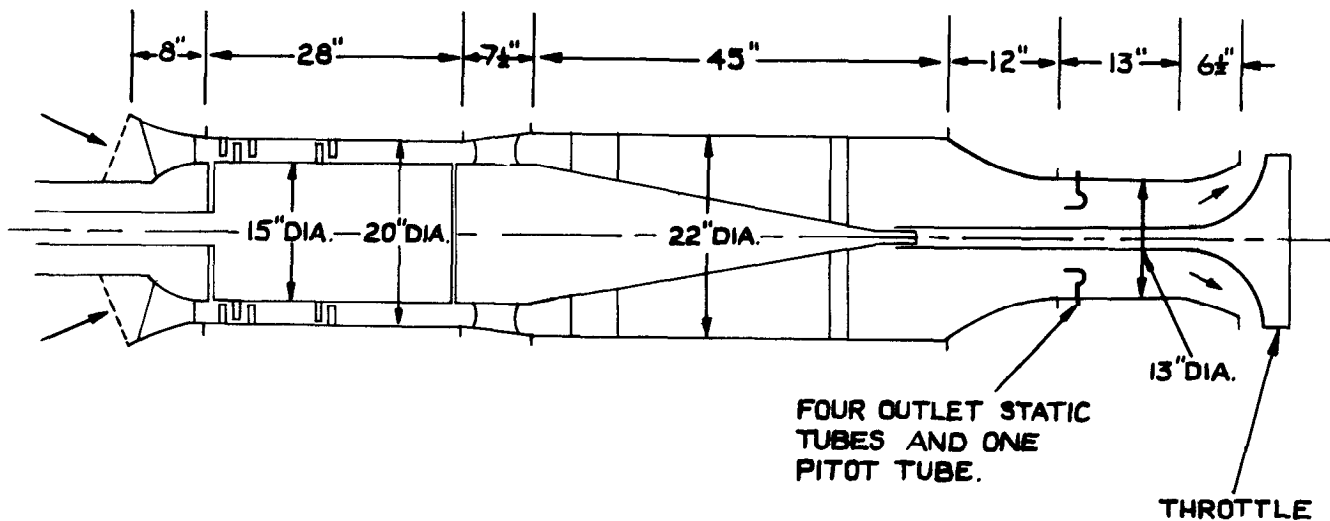

OVERALL DIMENSIONS OF ASSEMBLY

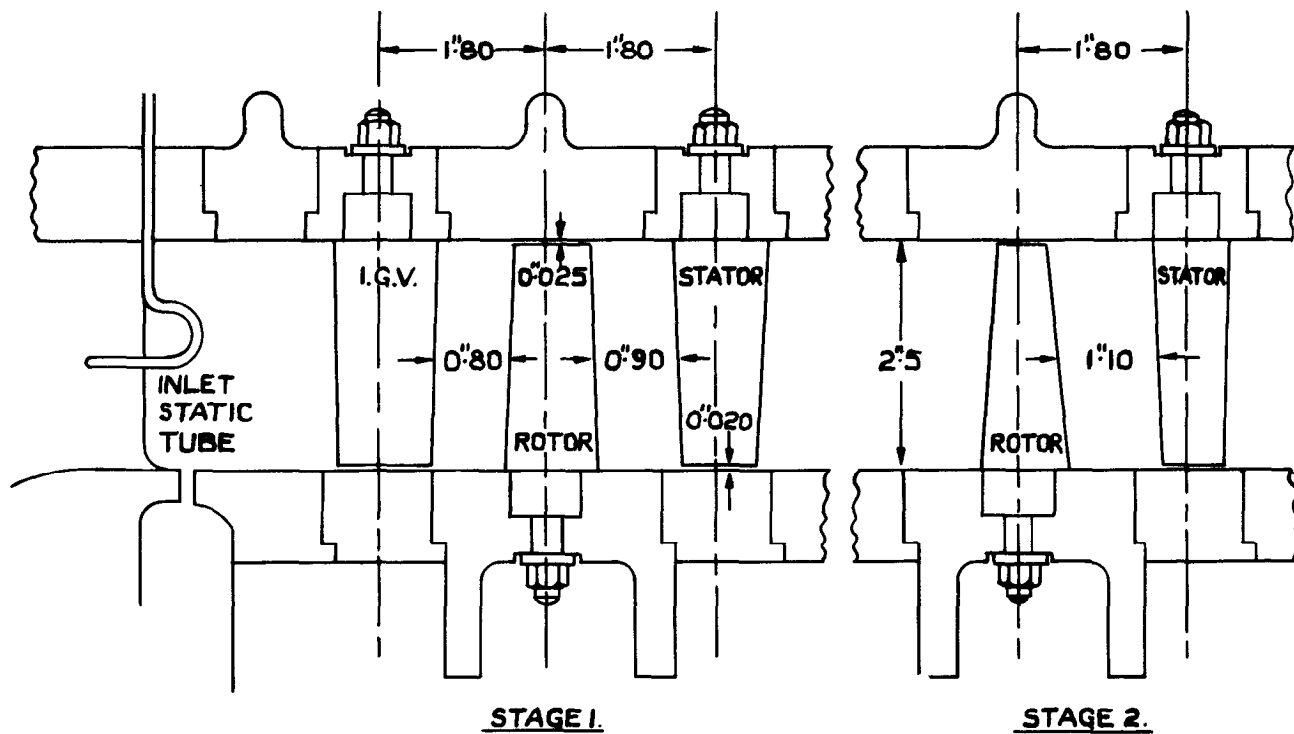

NOTE. STAGE 2 ROTOR AND STATOR BLADES ARE SIMILAR TO THOSE OF STAGE 1 BUT ARE INCREASED IN STAGGER BY 15°

BLADE SPACING — HALF X FULL SIZE

LEADING DIMENSIONS OF TEST RIG

FIG. 3.

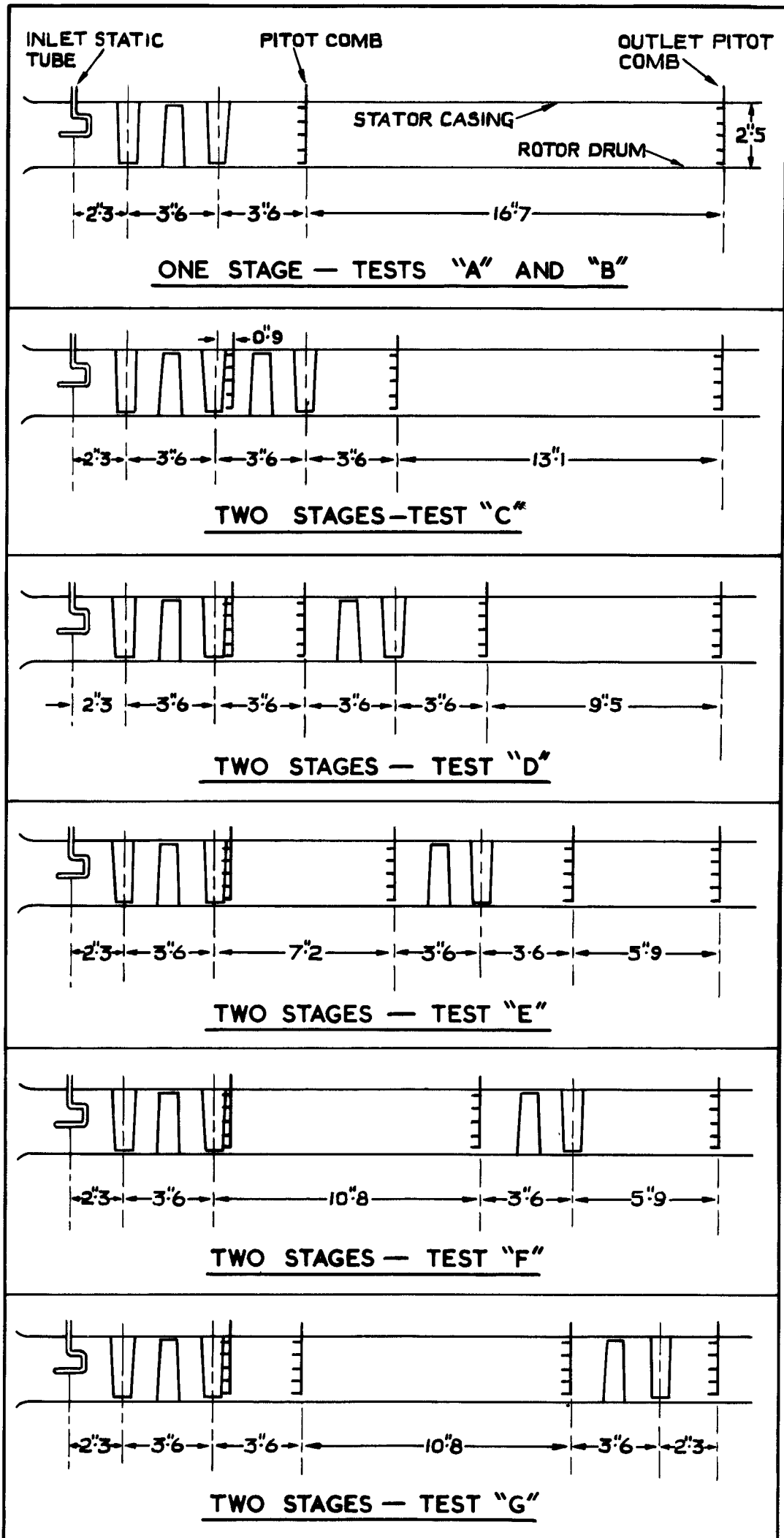

ARRANGEMENT OF STAGES FOR EACH TEST

FIG. 4.

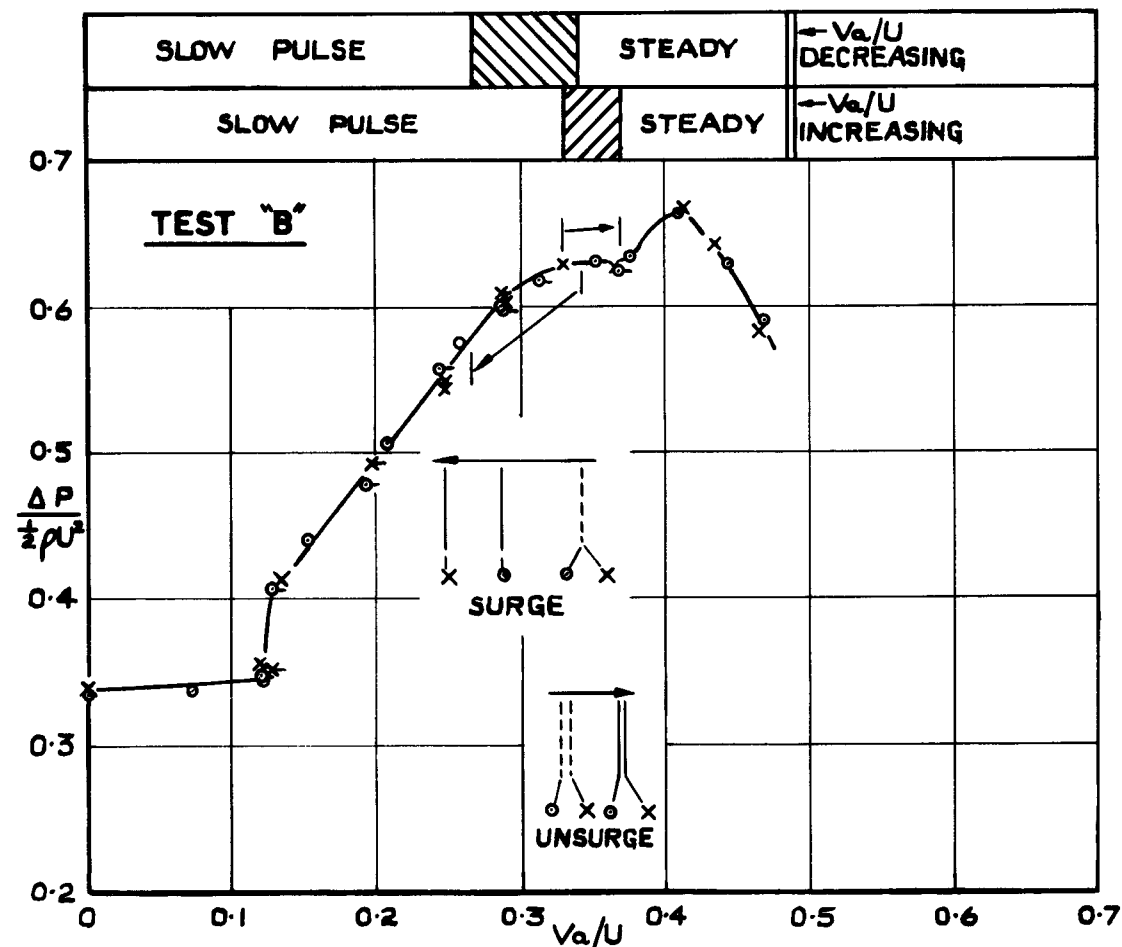
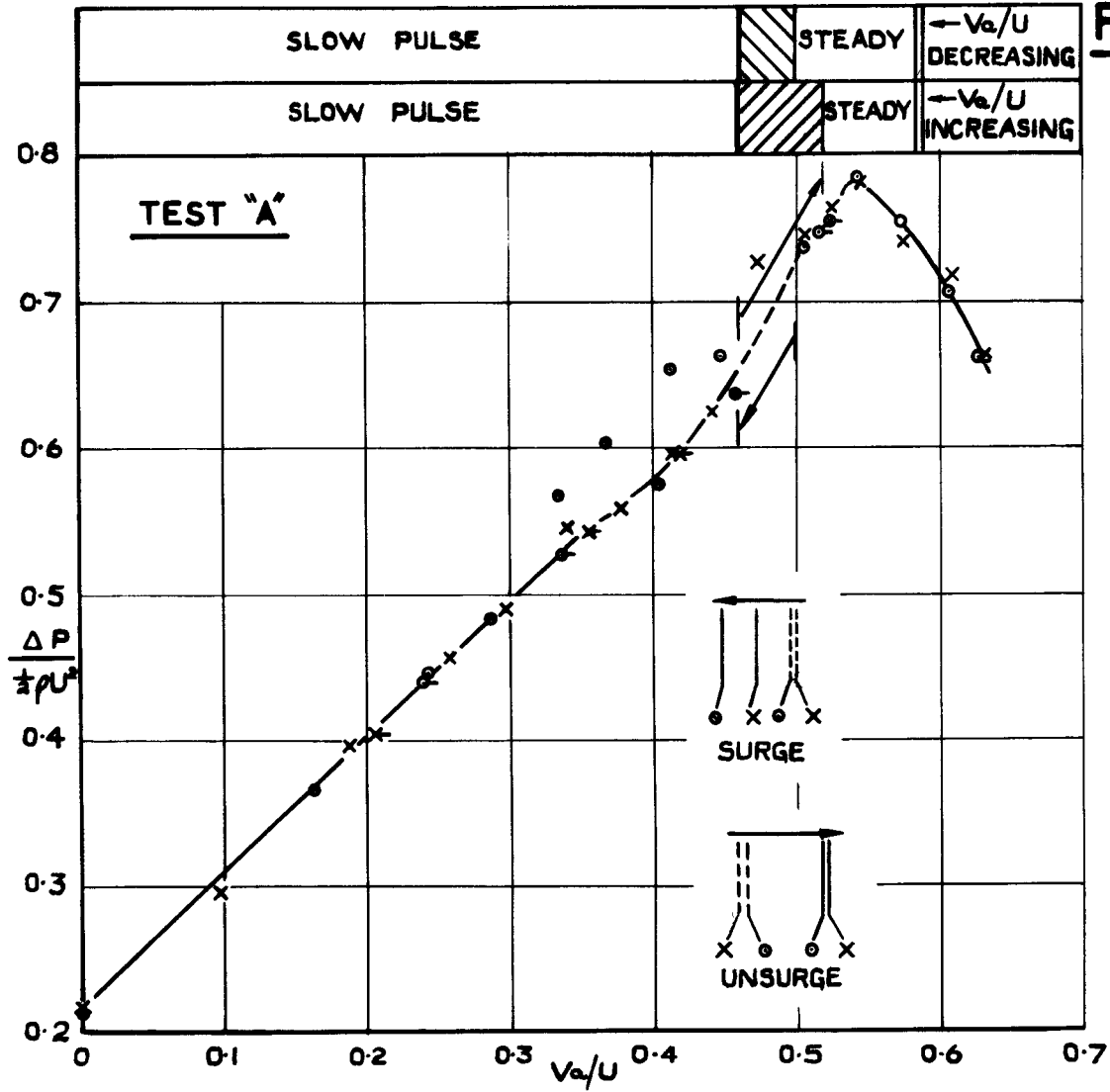

TEST RUNS DISTINGUISHED BY SYMBOLS
 TEST POINTS WITH INCREASING V_a/U SHOWN THUS: \otimes

CHARACTERISTICS — TESTS "A" AND "B"

FIG. 5.

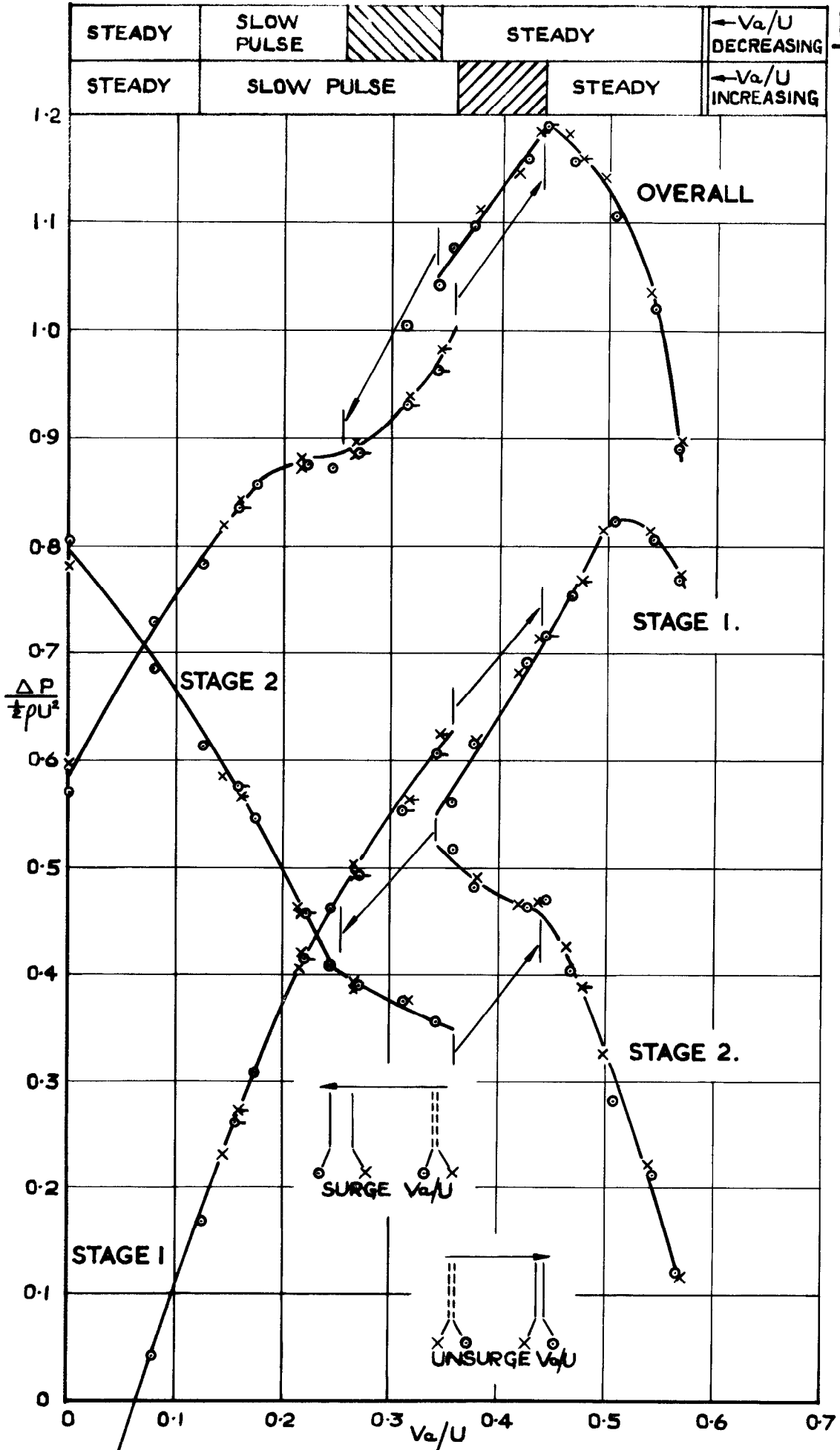

TEST RUNS DISTINGUISHED BY SYMBOLS
 TEST POINTS WITH INCREASING V_a/U SHOWN THUS: x
 INTERSTAGE SPACING = 1"8

CHARACTERISTICS — TEST "C"

FIG. 6.

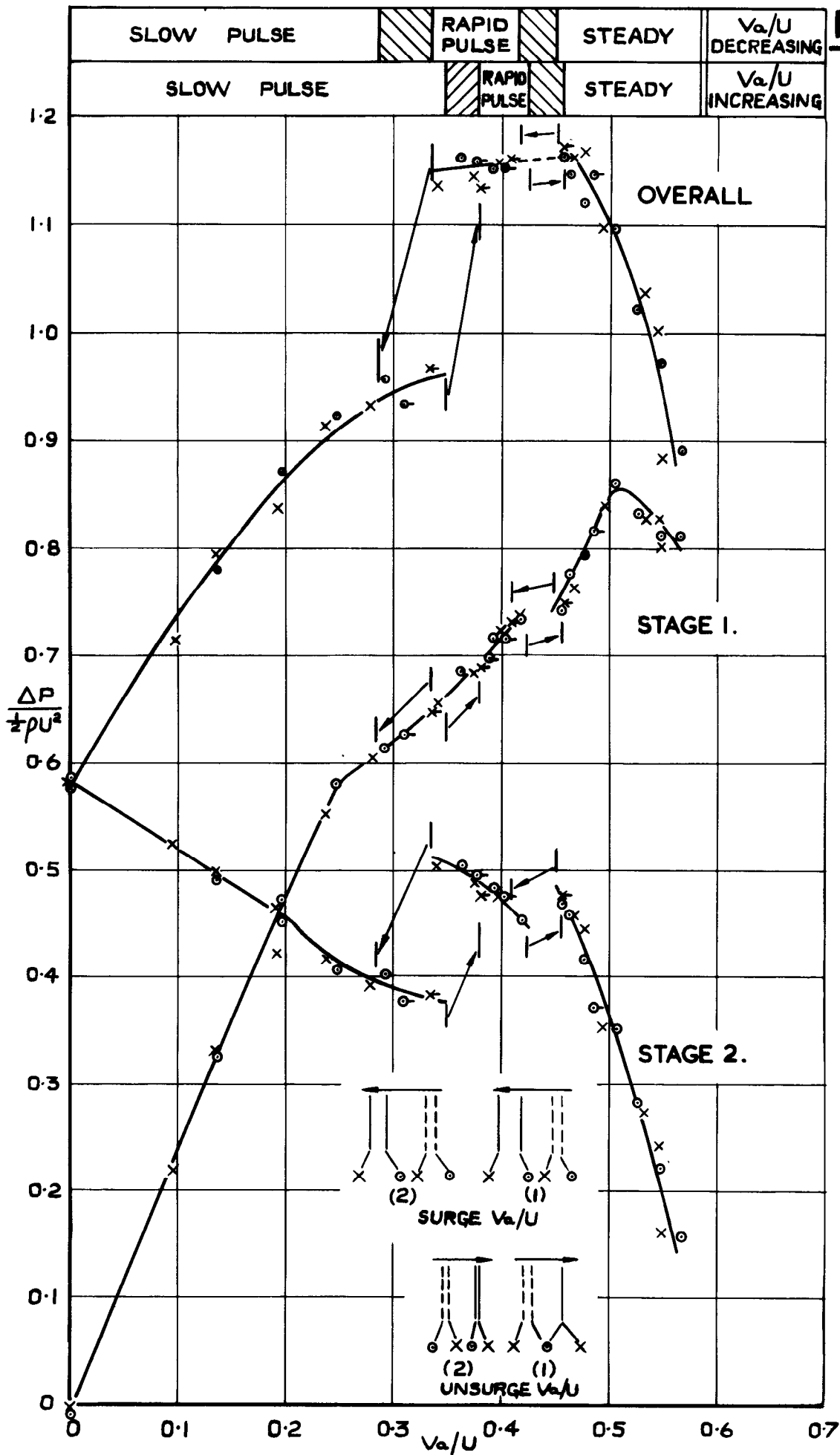

TEST RUNS DISTINGUISHED BY SYMBOLS
 TEST POINTS WITH INCREASING V_a/U SHOWN THUS: x
 INTERSTAGE SPACING = 5"4

CHARACTERISTICS — TEST "D"

FIG. 7.

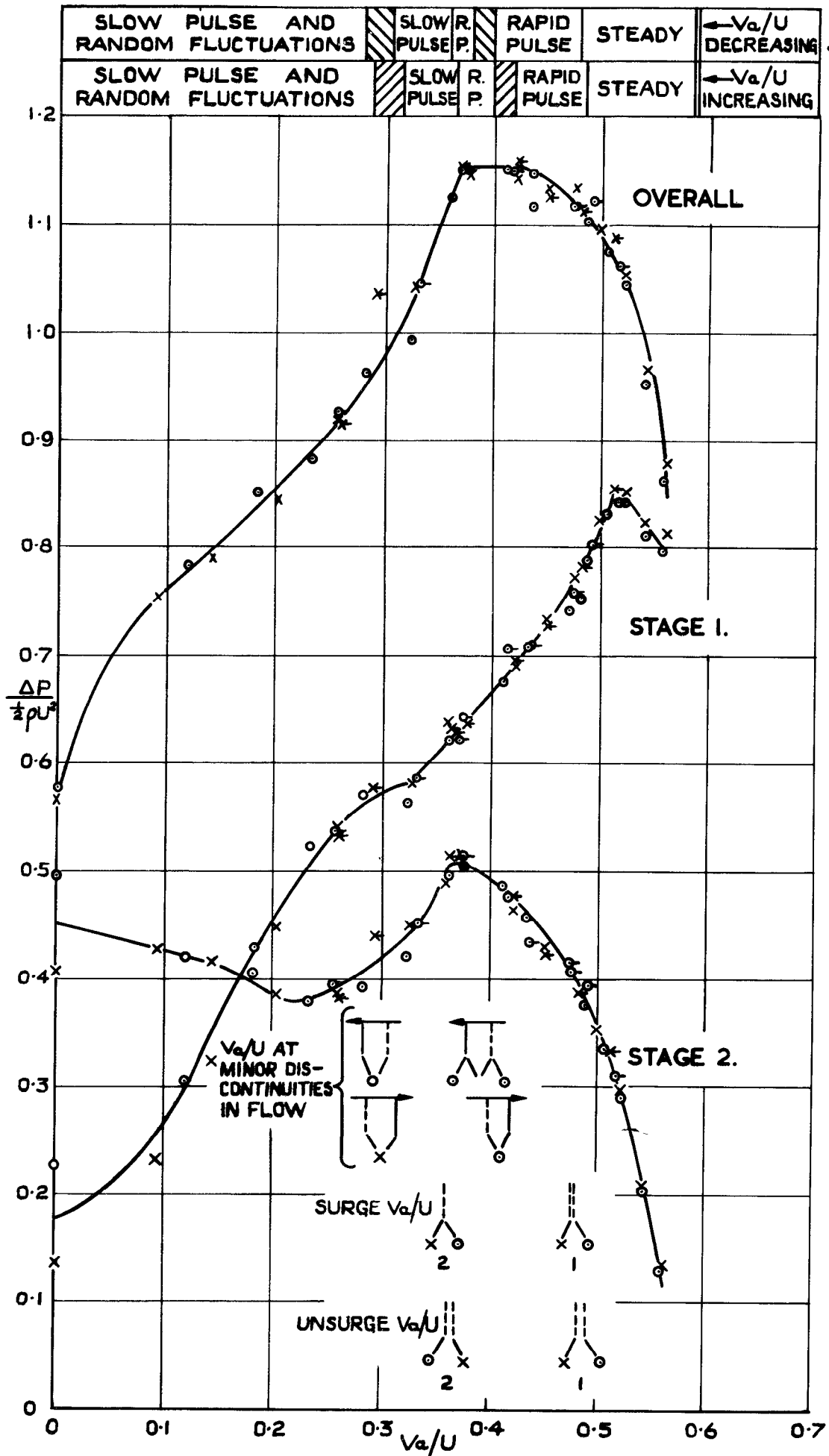

TEST RUNS DISTINGUISHED BY SYMBOLS
 TEST POINTS WITH INCREASING V_a/U SHOWN THUS: \circ
 INTERSTAGE SPACING = 9"0

CHARACTERISTICS — TEST "E"

FIG. 8.

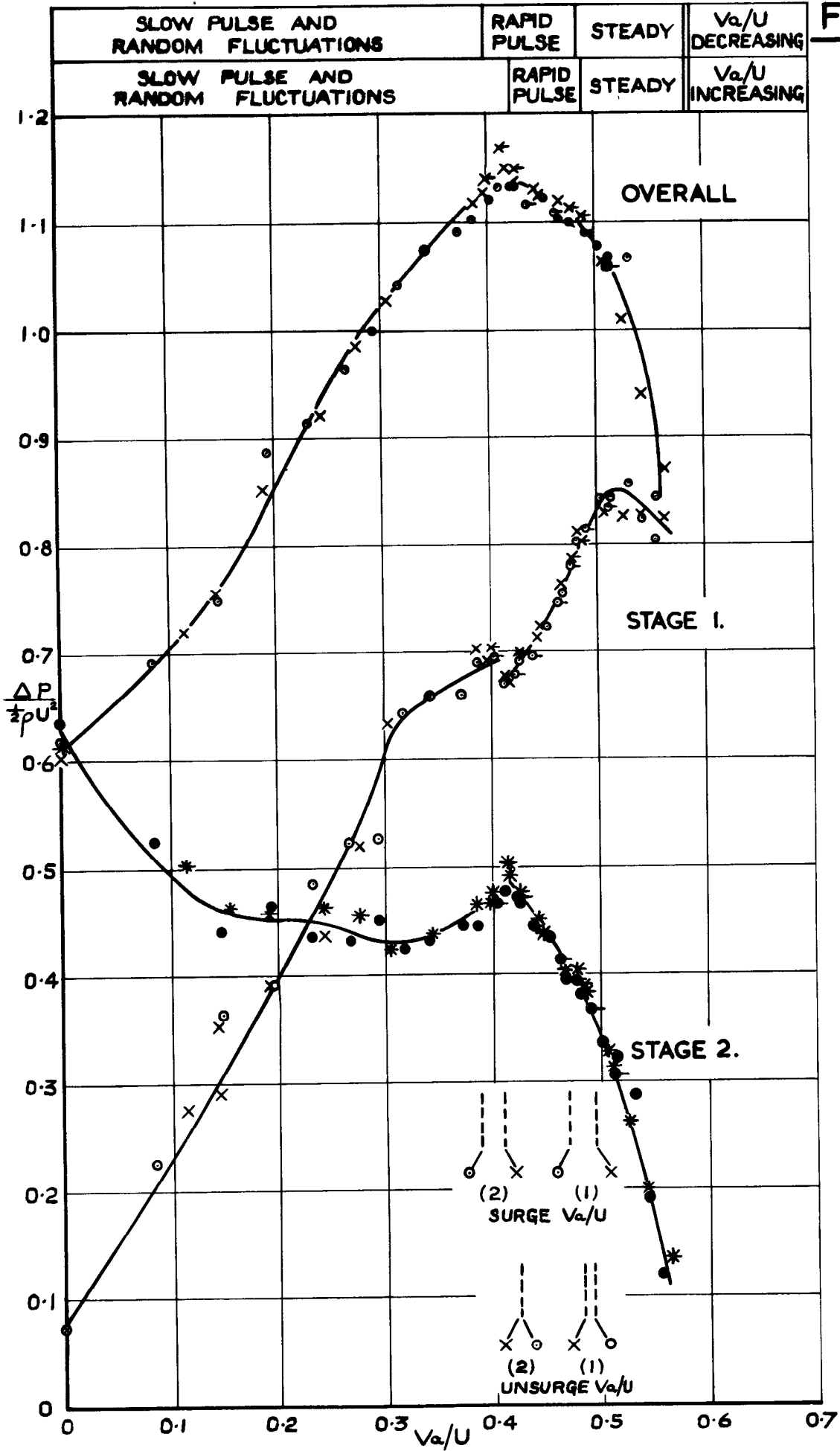

TEST RUNS DISTINGUISHED BY SYMBOLS
 TEST POINTS WITH INCREASING V_a/U SHOWN THUS: *
 INTERSTAGE SPACING = 12"6

CHARACTERISTICS—TEST "F"

FIG. 9.

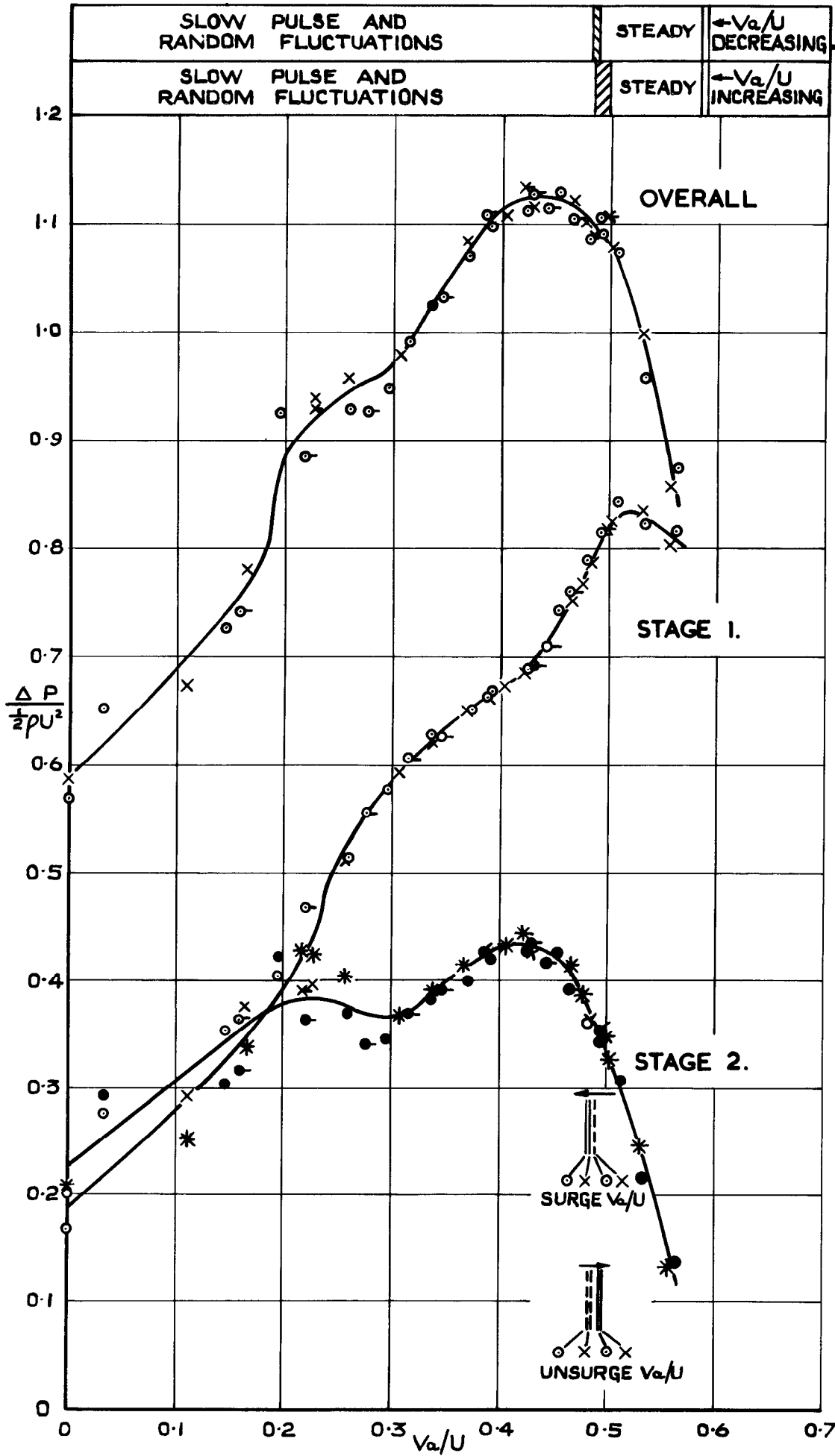

TEST RUNS DISTINGUISHED BY SYMBOLS
 TEST POINTS WITH INCREASING V_a/U SHOWN THUS: \otimes
 INTERSTAGE = SPACING 16"2

CHARACTERISTICS — TEST "G"

FIG. 10.

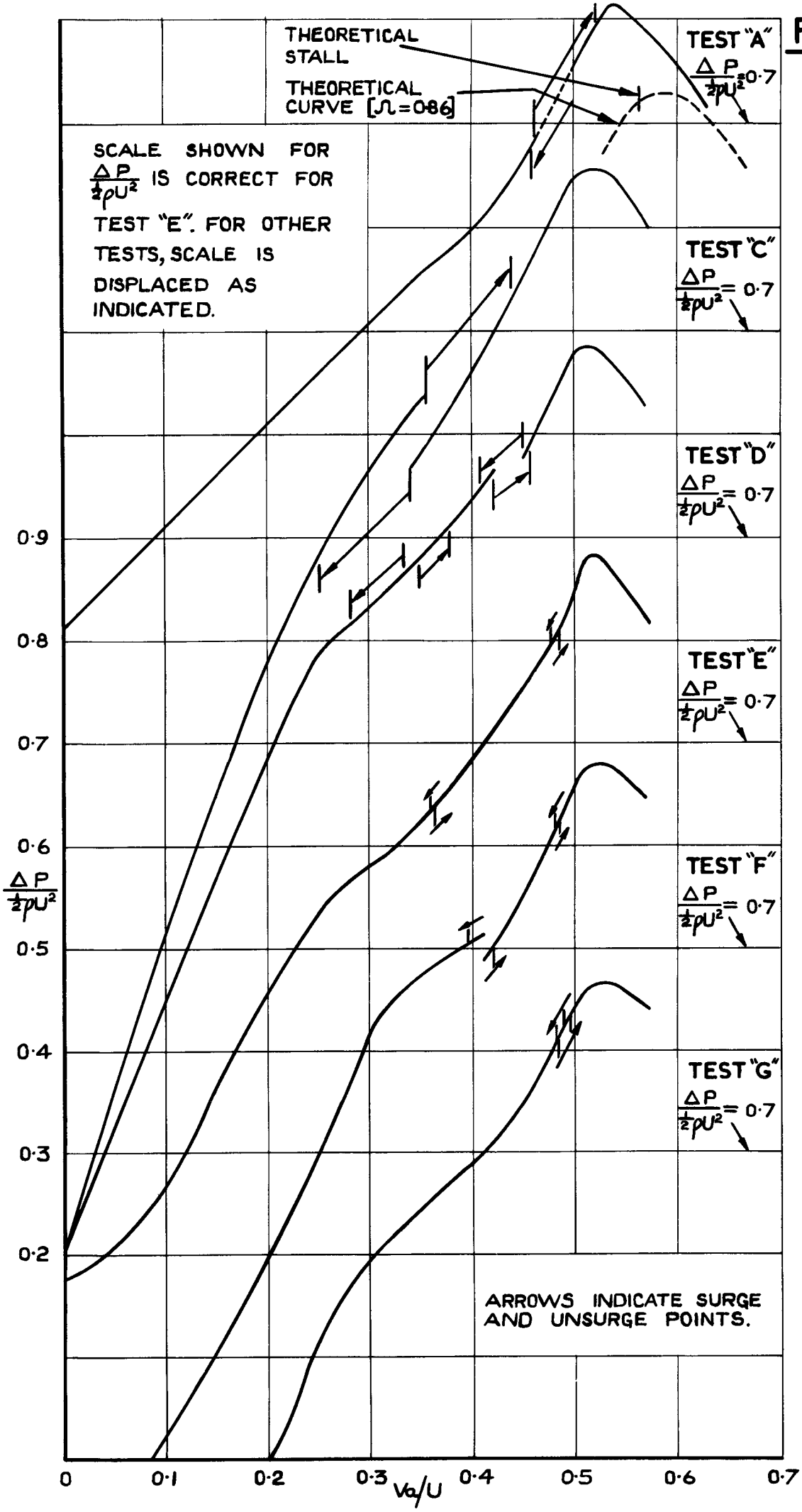

CHARACTERISTICS OF STAGE I

FIG. II.

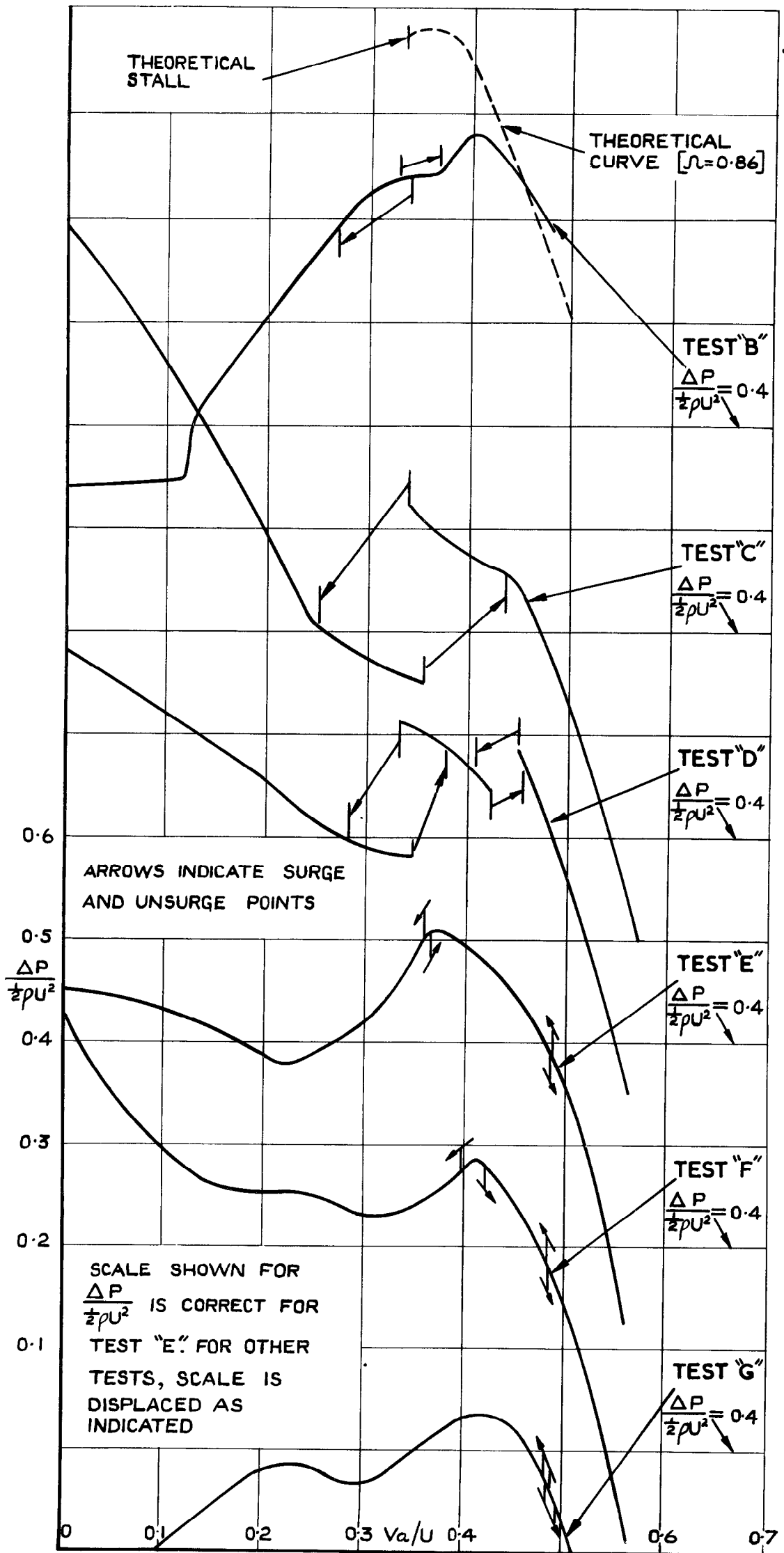

CHARACTERISTICS OF STAGE 2

FIG. 12.

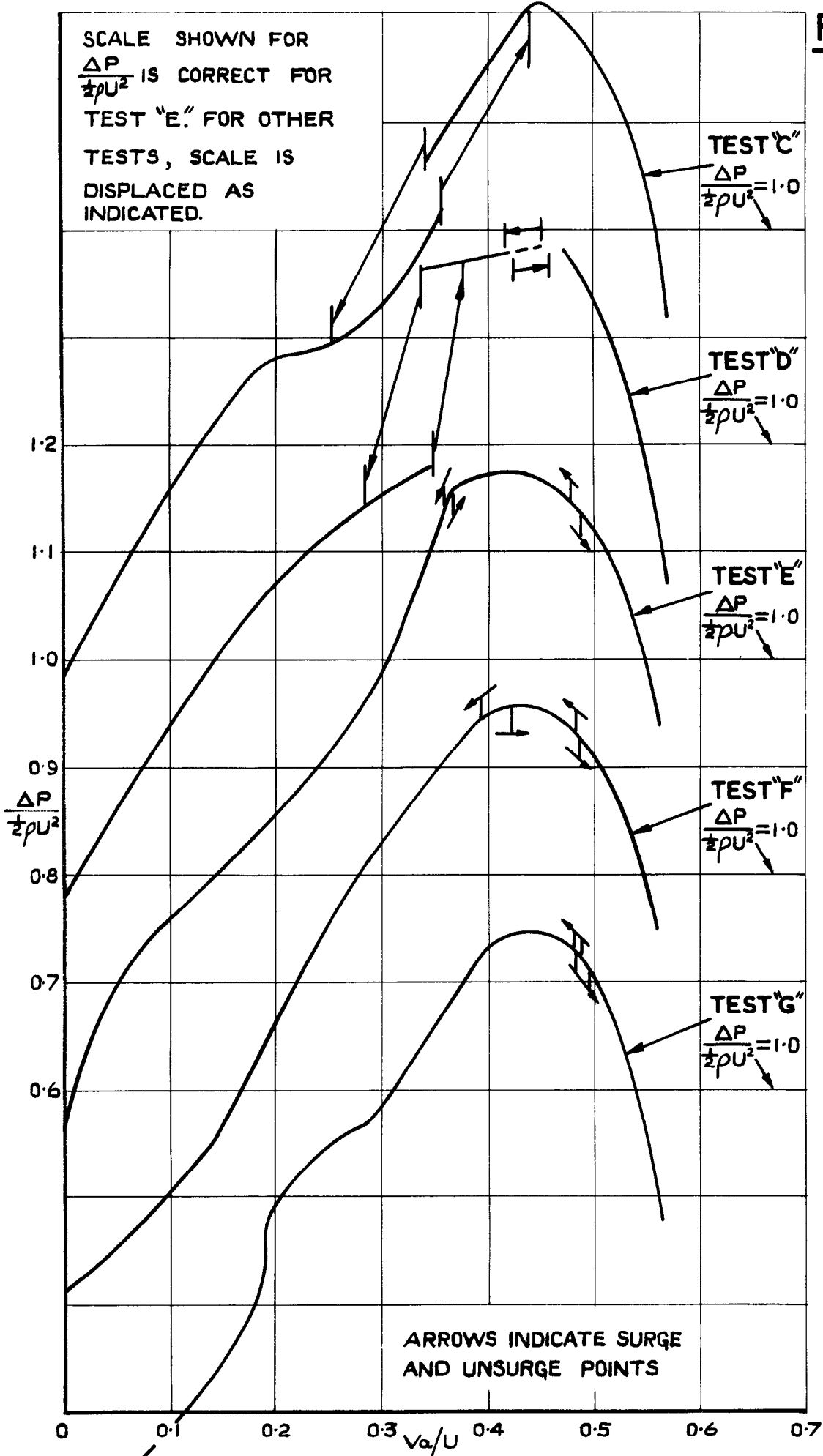

CHARACTERISTICS OF STAGES 1
AND 2 IN SERIES

V_a/U AT SURGE AND UNSURGE RELATED TO INTERSTAGE SPACING

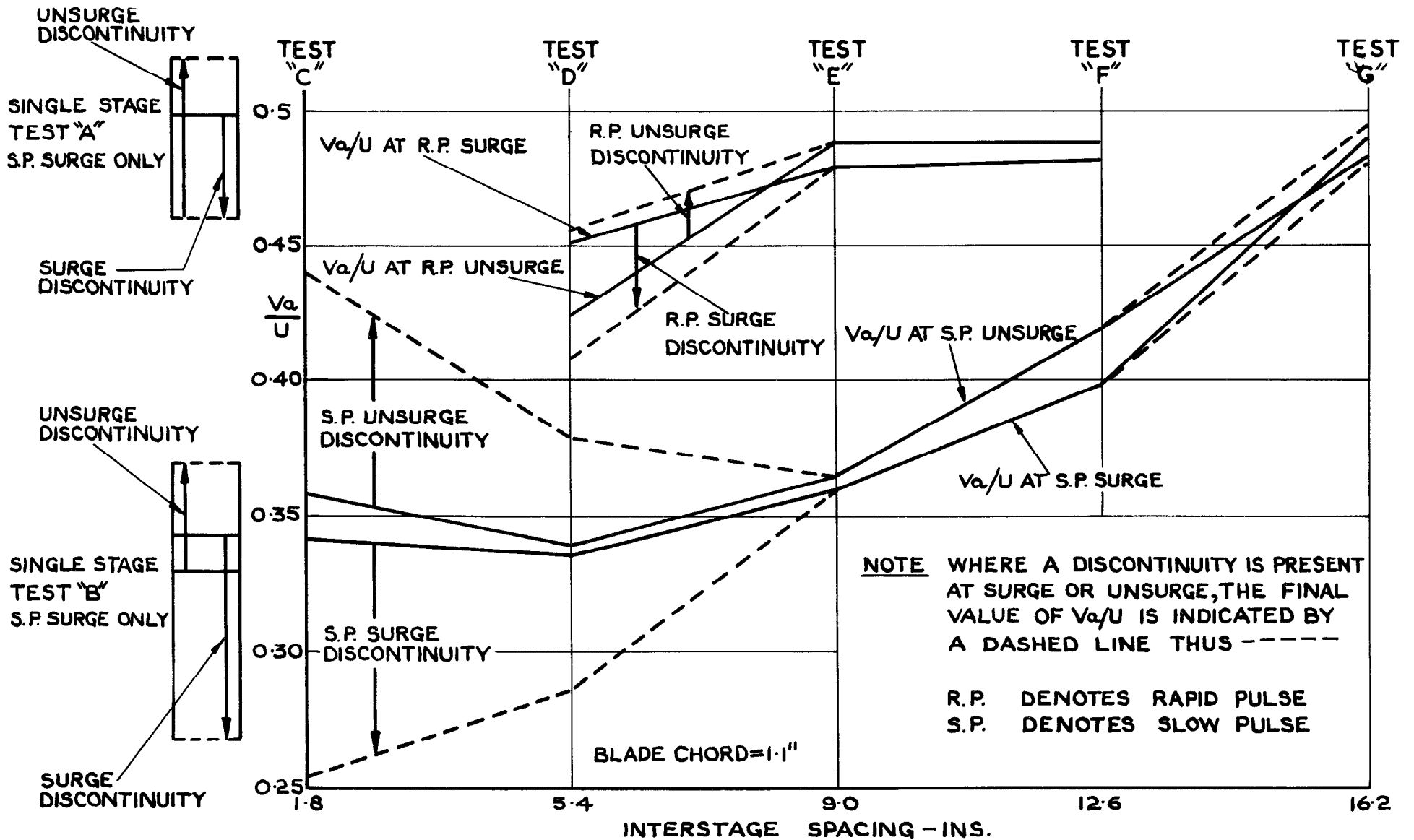

NOTE STAGE 1 HAS THE STAGGER SETTING OF TEST "A"
STAGE 2 HAS THE STAGGER SETTING OF TEST "B"

FIG. 13

FIG. 14.

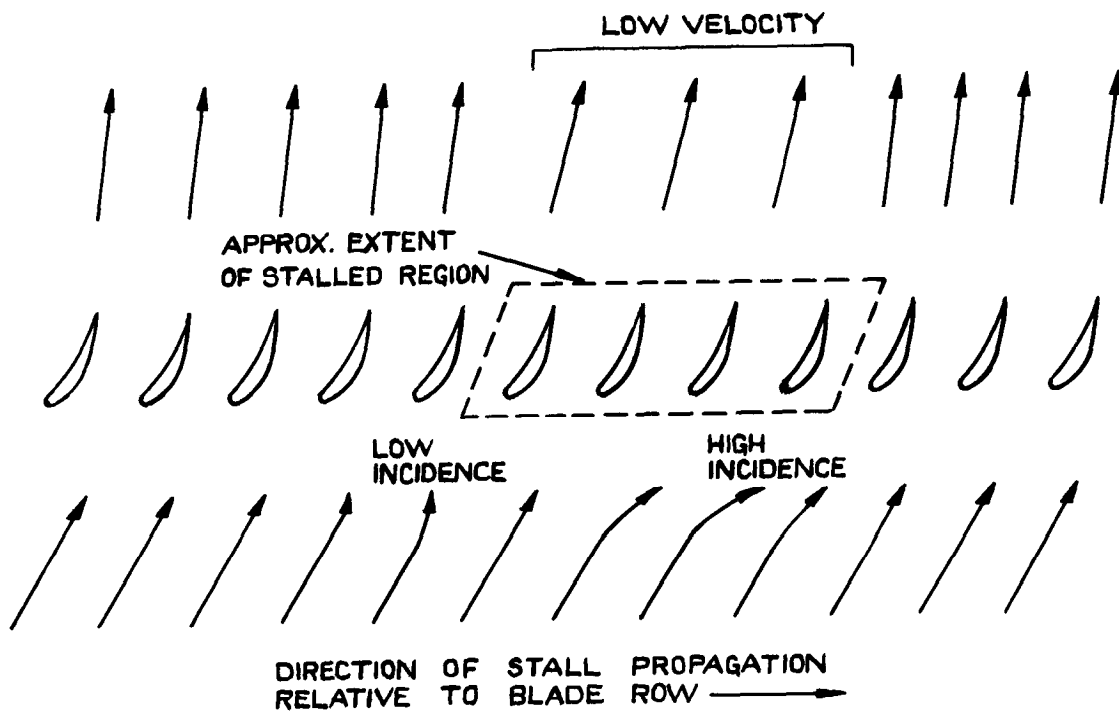

FLOW CONFIGURATION IN SINGLE ROW

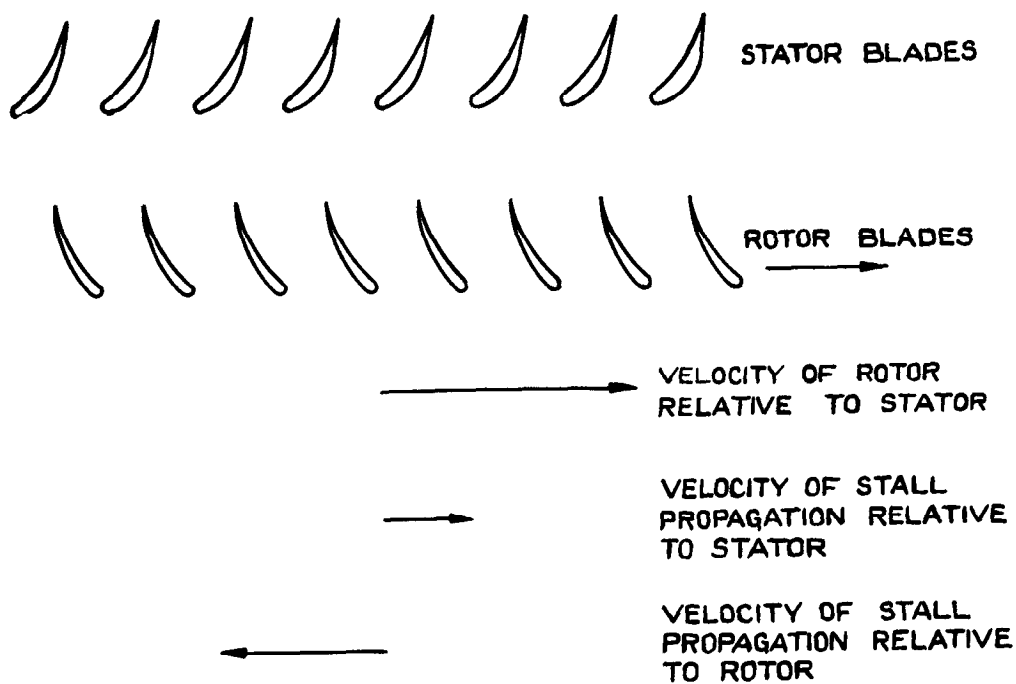

VELOCITY RELATIONSHIPS IN STAGE

STALL CELL PROPAGATION



C.P. No. 431

(18,877)

A.R.C. Technical Report

© *Crown copyright 1959*

Printed and published by
HER MAJESTY'S STATIONERY OFFICE

To be purchased from
York House, Kingsway, London W.C.2
423 Oxford Street, London W.1
13A Castle Street, Edinburgh 2
109 St Mary Street, Cardiff
39 King Street, Manchester 2
Tower Lane, Bristol 1
2 Edmund Street, Birmingham 3
80 Chichester Street, Belfast
or through any bookseller

Printed in Great Britain

S.O. Code No. 23-9011-31

C.P. No. 431