

LIBRARY COPY

R. & M. No. 2218

(8721)

A.R.C. Technical Report

NATIONAL AERONAUTICAL ESTABLISHMENT

LIBRARY



MINISTRY OF SUPPLY

AERONAUTICAL RESEARCH COUNCIL
REPORTS AND MEMORANDA

Tests of Contra-rotating Propellers of $2\frac{7}{8}$ -ft.
Diameter at Negative Pitch on a
"Typhoon" Aircraft Model

By

R. C. PANKHURST, PH.D., J. N. VEASEY, B.A., J. R. GREENING, B.Sc.
and Miss E. M. LOVE

of the Aerodynamics Division, N.P.L.

Crown Copyright Reserved.

LONDON: HIS MAJESTY'S STATIONERY OFFICE.

1948

Price 3s. od. net

LIBRARY

Tests of Contra-rotating Propellers of $2\frac{7}{8}$ -ft. Diameter at Negative Pitch on a "Typhoon" Aircraft Model

By

R. C. PANKHURST, PH.D., J. N. VEASEY, B.A., J. R. GREENING, B.Sc. and Miss E. M. LOVE
of the Aerodynamics Division, N.P.L.

Reports and Memoranda No. 2218

May, 1945

Summary.—The previous tests¹ of a pair of contra-rotating two-bladed propellers have been extended to the propeller "braking" condition by covering the range of pitch setting from 0 deg. to -30 deg. at the 0.7 radius. Measurements of overall thrust and individual torques were made up to an advance ratio (J) of 4.0, except that the 0 deg. settings were not tested beyond an advance ratio of 1.0 where the torque had already become negative.

LIST OF SYMBOLS

B	Back propeller. (The figure following indicates the number of blades)
c	Chord of blade element
C	Contra-rotating propellers. (The figure following indicates the number of blades)
D	Propeller diameter
D_M	Measured drag of wings and fuselage with propellers running
D_0	Drag of the complete aircraft with dummy spinners
F	Front propeller. (The figure following indicates the number of blades)
J	Advance ratio (V/nD)
k_Q	Torque coefficient ($Q/\rho n^2 D^5$)
k_S	Braking thrust coefficient ($S/\rho n^2 D^4$)
n	Rotational speed (r.p.s.)
N	Number of blades
Q	Torque
r	Radius at blade element
r_c	Fractional radius at blade element (r/R)
R	Tip radius
s	Solidity ($Nc/2\pi r$)
S	Braking thrust ($-T_M + D_M - D_0$)
S_C	Braking thrust coefficient ($S/\rho V^2 D^2$)
t	Thickness of blade element
T_M	Measured thrust (<i>i.e.</i> propeller thrust less the drag of spinners, suspension wires and exposed torque arms)
V	Forward speed
ϵ_0	Theoretical zero-lift angle
θ_0	Blade angle at radius r
θ	Blade angle at 0.7 radius
ρ	Air density

1. *Experimental Set-up.*—The apparatus used was that described in R. & M. 2216¹, with which measurements could be made of the overall thrust and of the individual torques of the contra-rotating propellers. In order to measure the negative thrusts a constant forward force was applied to the back of the motors through a horizontal strut by means of a weight suspended from the tunnel roof by a pair of wires inclined forwards at 45 deg. Details of the propellers are given in Table 1 and Figs. 1 and 2. They were two-bladers of 2 $\frac{7}{8}$ -ft. diameter; the total solidity at the 0.7 radius was 0.19 for the four blades.

2. *Range of Tests.*—The tests covered the range of pitch setting from 0 to -30 deg. at the 0.7 radius. The advance ratio (J) extended from tunnel "static" to 1.0 for the 0 deg. settings (*i.e.* well into the negative torque region) and to 4.0 for the negative pitch settings (for which the torque remained positive). The Reynolds number varied from 0.16 to 0.23×10^6 based on the blade chord at 0.7R, and from zero (tunnel "static") to 1.1×10^6 based on the wing mean chord.

The combinations of blade settings tested are set out in the following Table. Tests were also made on each propeller alone (*F 2* and *B 2*).

Contra-rotating (<i>C 2</i> \times 2)	0°/+2° 0°/0° 0°/-2°	-10°/-10° -10°/-12°	-20°/-20° -20°/-22°	-30°/-30° -30°/-32°
Front alone (<i>F 2</i>) ..	0°	-10°	-20°	-30°
Back alone (<i>B 2</i>) ..	0°	-10°	-20°	-30°

Wool tuft explorations of the general flow were made at the -30 deg. and the 0 deg. blade settings for both single and contra-rotating propellers.

3. *Results.*—The thrust measurements have been reduced to a braking force (S) analogous to the "propulsive thrust" normally used in the positive pitch region and defined by the equation

$$S = -T_M + D_M - D_o,$$

where T_M and D_M denote the measured thrust and the body drag respectively and D_o the drag of the body and dummy spinners in the absence of the propeller. The forms of coefficient which have been adopted are

$$k_s = S/\rho n^2 D^4$$

and

$$S_c = S/\rho V^2 D^2,$$

the former coefficient being the more convenient when $J < 1$ and the latter when $J > 1$.

Since

$$k_s = J^2 S_c,$$

the two forms are equal when $J = 1$.

No attempt was made to allow for tunnel interference.

The values of the braking thrust coefficients and of the usual torque coefficient k_0 are given in Tables 2 to 5, typical curves being shown plotted in Figs. 3 to 6, the thrusts of Fig. 5A being replotted on a larger scale in Fig. 5B for advance ratios less than 1.0. The braking thrust varies considerably with blade setting at low advance ratios, but varies little at high advance ratios.

The general nature of the flow as indicated by the wool tuft explorations in the airscrew "brake" condition is shown in Figs. 7 and 8.

At the blade setting of -30 deg. the flow through the propeller disc at tunnel "static" (Fig. 7A) is entirely in the direction from the trailing edge to the leading edge of the wing. At low advance ratios (Figs. 7B and 7C) the air at the tips flows towards the propeller disc from both sides and is presumably flung out radially. This condition might be referred to as a "vortex ring" state similar to that described in R. & M. 1014². As the advance ratio further increases, the flow through the propeller disc becomes entirely downstream (Fig. 7D), giving the "windmill brake" state².

At the 0 deg. blade setting the propeller develops a positive thrust at tunnel "static" (Fig. 8A), although the wool tufts suggest that the thrust grading is negative at the tips. The flow diverges markedly behind the propeller disc. As the advance ratio increases, the thrust becomes negative and the flow diverges much less.

At both blade settings the flow patterns for single and for contra-rotating propellers are closely similar. It should be emphasised that the flow indicated by the broken lines in Figs. 7 and 8 is somewhat speculative, but the positions shown for the wool tufts are those actually observed in the tunnel.

4. *Acknowledgement.*—The experimental work and the reduction of the observations were carried out with the assistance of Miss D. A. V. Phelps and Mr. P. J. W. Crockford.

REFERENCES

- | <i>No.</i> | <i>Author</i> | <i>Title, etc.</i> |
|------------|--|--|
| 1 | R. C. Pankhurst, J. N. Veasey, J. R. Greening and Miss E. M. Love. | Tests of Contra-rotating Propellers of 2½-ft. Diameter at Positive Pitch on a "Typhoon" Aircraft Model. R. & M. 2216. October, 1945. |
| 2 | C. N. H. Lock, H. Bateman and H. C. H. Townend. | An Extension of the Vortex Theory of Airscrews with Applications to Airscrews of Small Pitch and Including Experimental Results. R. & M. 1014. June, 1926. |
-

TABLE 1
Blade Data for 2 $\frac{7}{8}$ -ft Diameter Propellers. All Dimensions in Inches.

Front Propeller

Section	r	r_o	x/c	0	0.05	0.1	0.2	0.35	0.5	0.65	0.8	1.0	L.E.R.	T.E.R.	c	* ϵ_0°	† θ_0°	s/N	t/c
A	2.08	0.1207	U	0	+0.24	+0.33	+0.46	+0.53	+0.51	+0.43	+0.30	0	0.20	0.16	3.32	-1.33	73.15	0.2537	0.338
			L	0	-0.24	-0.34	-0.47	-0.58	-0.58	-0.50	-0.36	0							
B	3.00	0.1741	U	0	+0.25	+0.36	+0.50	+0.55	+0.52	+0.42	+0.30	0	0.19	0.13	3.54	-0.42	71.95	0.1875	0.313
			L	0	-0.21	-0.31	-0.44	-0.55	-0.55	-0.47	-0.31	0							
C	4.00	0.2321	U	0	+0.26	+0.38	-0.53	+0.58	+0.54	+0.42	+0.29	0	0.15	0.10	3.68	+1.50	71.55	0.1463	0.281
			L	0	-0.20	-0.29	-0.41	-0.46	-0.43	-0.35	-0.24	0							
D	6.75	0.3914	U	0.22	+0.50	+0.61	+0.71	+0.72	+0.66	+0.52	+0.35	0.04	0.08	0.05	3.84	7.40	63.15	0.0914	0.188
			L	0.22	0.06	0.02	0	0	0	0	0	0.04							
E	9.50	0.551	U	0.16	0.38	0.47	0.54	0.56	0.50	0.39	0.26	0.04	0.07	0.04	3.95	5.33	55.65	0.0662	0.142
			L	0.16	0.05	0.02	0	0	0	0	0	0.04							
F	12.25	0.710	U	0.12	0.29	0.36	0.41	0.42	0.38	0.30	0.19	0.02	0.05	0.02	3.60	4.46	49.60	0.0468	0.117
			L	0.12	0.04	0.02	0	0	0	0	0	0.02							
G	15.00	0.870	U	0.08	0.19	0.23	0.26	0.28	0.25	0.20	0.13	0.02	0.04	0.02	2.70	3.77	45.30	0.0286	0.102
			L	0.08	0.03	0.02	0	0	0	0	0	0.02							

Back Propeller (Where Different)

Section	r	r_o	x/c	0	0.05	0.1	0.2	0.35	0.5	0.65	0.8	1.0	L.E.R.	T.E.R.	c	ϵ_0°	θ_0°	s/N	t/c
B'	4.00	0.2319	U	0	+0.26	+0.37	+0.50	+0.55	+0.52	+0.42	+0.30	0	0.19	0.13	3.54	-0.41	71.95	0.1409	0.313
			L	0	-0.22	-0.31	-0.44	-0.54	-0.54	-0.46	-0.33	0							
C'	5.37	0.3115	U	0	+0.28	+0.41	+0.54	+0.58	+0.54	+0.43	+0.28	0	0.15	0.07	3.78	+3.02	69.65	0.1120	0.246
			L	0	-0.20	-0.26	-0.33	-0.35	-0.31	-0.24	-0.17	0							

*Calculated from the section shapes.

†Adjusted to be 50 deg. at 0.7 R.

Distance between front and back propellers = 4 in. (0.116D)

TABLE 2
 Faired Experimental Data at $\theta_F = 0$ deg.
 (Diameter $2\frac{7}{8}$ -ft.)

J	C 2 x 2						F2		B2		
	Mean* k_{QP}	0°/+2°		0°/0°		0°/-2°		0°		0°	
		k_{QB}	k_s	k_{QB}	k_s	k_{QB}	k_s	k_Q	k_s	k_Q	k_s
0.1	0.0019	0.0021	-0.041	0.0015	-0.030	0.0011	-0.022	0.0019	-0.021	0.0018	-0.020
0.2	0.0018	0.0018	-0.025	0.0012	-0.010	0.0008	+0.003	0.0018	-0.008	0.0016	-0.006
0.3	0.0016	0.0015	0.004	0.0009	+0.020	0.0006	0.033	0.0016	+0.015	0.0013	+0.019
0.4	0.0013	0.0010	0.040	+0.0004	0.054	0.0004	0.066	0.0012	0.040	0.0009	0.044
0.5	0.0007	0.0003	0.077	-0.0001	0.093	0.0003	0.104	0.0006	0.065	+0.0004	0.068
0.6	-0.0001	-0.0006	0.118	-0.0006	0.133	0.0002	0.146	+0.0001	0.090	-0.0002	0.093
0.7	-0.0006	-0.0014	0.163	-0.0009	0.177	+0.0001	0.190	-0.0010	0.117	-0.0009	0.118
0.8	-0.0014	-0.0020	0.209	-0.0011	0.224	-0.0001	0.237	-0.0020	0.144	-0.0017	0.143
0.9	-0.0023	-0.0027	0.258	-0.0017	0.274	-0.0005	0.287	-0.0031	0.170	-0.0025	0.167
1.0	-0.0033	-0.0034	0.306	-0.0024	0.325	—	—	-0.0044	0.197	-0.0036	0.192
1.1								-0.0057	0.225		
1.2								-0.0070	0.252		
1.3								-0.0085	0.279		

*From a single curve drawn through the k_{QP} 's for the three settings of the back propeller.

TABLE 3

Faired Experimental Data at $\theta_F = -10$ deg.
(Diameter $2\frac{7}{8}$ -ft.)

J	C 2 × 2							F2			B2		
	Mean* k_{QP}	-10°/-10°			-10°/-12°			-10°			-10°		
		k_{QB}	k_s	S_G	k_{QB}	k_s	S_G	k_Q	k_s	S_G	k_Q	k_s	S_G
0	0.0024	0.0033	0.040		0.0048	0.048		0.0036	0.019		0.0036	0.023	
0.1	0.0023	0.0029	0.057		0.0042	0.066		0.0036	0.032		0.0036	0.036	
0.2	0.0027	0.0028	0.080		0.0042	0.090		0.0039	0.047		0.0039	0.051	
0.3	0.0034	0.0030	0.104		0.0047	0.115		0.0047	0.066		0.0048	0.068	
0.4	0.0043	0.0033	0.136		0.0050	0.147		0.0055	0.088		0.0060	0.089	
0.5	0.0054	0.0039	0.172		0.0056	0.186		0.0063	0.117		0.0068	0.117	
0.6	0.0063	0.0044	0.220		0.0061	0.229		0.0070	0.151		0.0074	0.150	
0.7	0.0070	0.0051	0.269		0.0070	0.280		0.0073	0.186		0.0078	0.181	
0.8	0.0074	0.0059	0.319		0.0079	0.331		0.0073	0.216		0.0080	0.209	
0.9	0.0076	0.0068	0.371		0.0089	0.381		0.0072	0.246		0.0081	0.237	
1.0	0.0073	0.0078	0.424	0.424	0.0098	0.434	0.434	0.0071	0.273	0.273	0.0081	0.265	0.265
1.1	0.0071	0.0087	0.478	0.395	0.0105	0.491	0.406	0.0069	0.298	0.246	0.0080	0.292	0.241
1.2	0.0070	0.0090	0.532	0.369	0.0112	0.546	0.379	0.0066	0.323	0.224	0.0082	0.315	0.219
1.3	0.0068	0.0093	0.589	0.349	0.0119	0.600	0.355	0.0065	0.347	0.205	0.0084	0.336	0.199
1.4	0.0066	0.0094	0.647	0.330	0.0124	0.659	0.336	0.0064	0.370	0.189	0.0087	0.356	0.182
1.5	0.0066	0.0097	0.704	0.313	0.0130	0.717	0.319	0.0065	0.392	0.174	0.0090	0.374	0.166
1.6	0.0064	0.0098	0.765	0.299	0.0134	0.774	0.302	0.0066	0.414	0.162	0.0094	0.392	0.153
1.7	0.0064	0.0098	0.818	0.283	0.0140	0.826	0.286	0.0069	0.436	0.151	0.0098	0.408	0.141
1.8	0.0065	0.0099	0.862	0.266	0.0144	0.869	0.268	0.0072	0.457	0.141	0.0101	0.425	0.131
1.9	0.0065	0.0100	0.895	0.248	0.0150	0.903	0.250	0.0074	0.479	0.133	0.0105	0.443	0.123
2.0	0.0067	0.0106	0.928	0.232	0.0160	0.940	0.235	0.0077	0.501	0.125	0.0108	0.462	0.116
2.1	0.0069	0.0112	0.965	0.219	0.0169	0.974	0.221	0.0080	0.523	0.119	0.0112	0.481	0.109
2.2	0.0073	0.0119	1.002	0.207	0.0178	1.009	0.208	0.0082	0.544	0.112	0.0116	0.500	0.103
2.3	0.0082	0.0126	1.043	0.197	0.0187	1.048	0.198	0.0085	0.565	0.107	0.0120	0.518	0.098
2.4	0.0091	0.0133	1.088	0.189	0.0196	1.088	0.189	0.0088	0.587	0.102	0.0123	0.538	0.093
2.5	0.0099	0.0140	1.131	0.181	0.0203	1.131	0.181	0.0090	0.609	0.097	0.0127	0.557	0.089
2.6	0.0105	0.0147	1.177	0.174	0.0211	1.177	0.174	0.0093	0.630	0.093	0.0130	0.578	0.086
2.7	0.0112	0.0153	1.227	0.168	0.0220	1.227	0.168	0.0096	0.652	0.089	0.0135	0.598	0.082
2.8	0.0118	0.0161	1.279	0.163	0.0229	1.279	0.163	0.0099	0.674	0.085	0.0138	0.618	0.079
2.9	0.0123	0.0169	1.331	0.158	0.0237	1.331	0.158	0.0102	0.697	0.083	0.0143	0.639	0.076
3.0	0.0129	0.0174	1.385	0.154	0.0244	1.385	0.154	0.0105	0.719	0.080	0.0147	0.659	0.073
3.1	0.0133	0.0180	1.439	0.150	0.0251	1.439	0.150	0.0107	0.741	0.077	0.0150	0.681	0.071
3.2	0.0138	0.0184	1.496	0.146	0.0258	1.496	0.146	0.0110	0.763	0.075	0.0154	0.702	0.069
3.3	0.0141	0.0189	1.552	0.143	0.0265	1.552	0.143	0.0113	0.785	0.072	0.0158	0.723	0.066
3.4	0.0146	0.0192	1.608	0.139	0.0270	1.608	0.139	0.0116	0.807	0.070	0.0162	0.744	0.064
3.5	0.0150	0.0195	1.666	0.136	0.0277	1.666	0.136	0.0120	0.829	0.068	0.0166	0.764	0.062
3.6	0.0152	0.0199	1.723	0.133	0.0281	1.723	0.133	0.0123	0.851	0.066	0.0170	0.786	0.061
3.7	0.0156	0.0200	1.782	0.130	0.0287	1.782	0.130	0.0126	0.873	0.064	0.0174	0.807	0.059
3.8	0.0160	0.0202	1.841	0.127	0.0290	1.841	0.127	0.0129	0.895	0.062	0.0178	0.828	0.057
3.9	0.0162	0.0204	1.899	0.125	0.0293	1.899	0.125	0.0132	0.916	0.060	0.0182	0.849	0.056
4.0	0.0165	0.0206	1.959	0.122	0.0296	1.959	0.122	0.0136	0.938	0.059	0.0187	0.871	0.054

*From a single curve drawn through the k_{QP} 's for both settings of back propeller.

TABLE 4

Faired Experimental Data at $\theta_F = -20$ deg.
(Diameter $2\frac{7}{8}$ -ft.)

J	C 2 × 2								F2			B2		
	-20°/-20°				-20°/-22°				-20°			-20°		
	k_{QF}	k_{QB}	k_s	S_c	k_{QF}	k_{QB}	k_s	S_c	k_Q	k_s	S_c	k_Q	k_s	S_c
0	0.0104	0.0123	0.120		0.0104	0.0143	0.131		0.0120	0.068		0.0121	0.072	
0.1	0.0107	0.0117	0.121		0.0107	0.0141	0.130		0.0121	0.077		0.0122	0.079	
0.2	0.0112	0.0113	0.131		0.0112	0.0140	0.141		0.0123	0.089		0.0124	0.092	
0.3	0.0121	0.0113	0.155		0.0121	0.0140	0.163		0.0127	0.105		0.0130	0.109	
0.4	0.0134	0.0117	0.191		0.0134	0.0144	0.201		0.0144	0.126		0.0147	0.129	
0.5	0.0154	0.0123	0.230		0.0154	0.0149	0.242		0.0166	0.151		0.0171	0.153	
0.6	0.0172	0.0133	0.275		0.0172	0.0157	0.287		0.0189	0.179		0.0194	0.180	
0.7	0.0190	0.0148	0.322		0.0190	0.0169	0.335		0.0208	0.216		0.0214	0.216	
0.8	0.0204	0.0165	0.371		0.0204	0.0187	0.384		0.0225	0.252		0.0230	0.249	
0.9	0.0221	0.0188	0.423		0.0221	0.0208	0.438		0.0238	0.288		0.0244	0.283	
1.0	0.0237	0.0211	0.479	0.479	0.0237	0.0234	0.495	0.495	0.0246	0.319	0.319	0.0254	0.310	0.310
1.1	0.0250	0.0233	0.538	0.445	0.0250	0.0260	0.552	0.456	0.0251	0.344	0.284	0.0263	0.335	0.277
1.2	0.0262	0.0253	0.598	0.415	0.0262	0.0286	0.614	0.426	0.0256	0.367	0.255	0.0269	0.356	0.247
1.3	0.0273	0.0273	0.661	0.391	0.0273	0.0309	0.478	0.401	0.0264	0.389	0.230	0.0276	0.376	0.222
1.4	0.0283	0.0294	0.725	0.371	0.0283	0.0334	0.738	0.377	0.0273	0.408	0.208	0.0285	0.394	0.201
1.5	0.0292	0.0311	0.787	0.350	0.0292	0.0357	0.794	0.353	0.0283	0.427	0.190	0.0296	0.409	0.182
1.6	0.0300	0.0331	0.840	0.328	0.0300	0.0379	0.846	0.330	0.0295	0.447	0.175	0.0308	0.426	0.166
1.7	0.0307	0.0350	0.890	0.308	0.0307	0.0399	0.892	0.309	0.0307	0.466	0.161	0.0322	0.442	0.153
1.8	0.0314	0.0363	0.934	0.288	0.0314	0.0414	0.934	0.288	0.0319	0.483	0.150	0.0334	0.458	0.141
1.9	0.0325	0.0371	0.961	0.266	0.0325	0.0420	0.961	0.266	0.0330	0.506	0.140	0.0346	0.474	0.131
2.0	0.0339	0.0377	0.980	0.245	0.0339	0.0422	0.980	0.245	0.0341	0.526	0.132	0.0356	0.491	0.123
2.1	0.0351	0.0379	0.997	0.226	0.0351	0.0427	0.997	0.226	0.0351	0.547	0.124	0.0368	0.507	0.115
2.2	0.0363	0.0384	1.024	0.212	0.0363	0.0436	1.024	0.212	0.0362	0.567	0.117	0.0379	0.523	0.108
2.3	0.0377	0.0396	1.063	0.201	0.0377	0.0451	1.063	0.201	0.0373	0.587	0.111	0.0390	0.540	0.102
2.4	0.0388	0.0411	1.107	0.192	0.0388	0.0472	1.107	0.192	0.0384	0.607	0.105	0.0402	0.557	0.097
2.5	0.0399	0.0431	1.150	0.184	0.0401	0.0497	1.150	0.184	0.0394	0.628	0.100	0.0413	0.574	0.092
2.6	0.0412	0.0451	1.198	0.177	0.0416	0.0522	1.199	0.177	0.0405	0.649	0.096	0.0424	0.593	0.088
2.7	0.0426	0.0472	1.246	0.171	0.0432	0.0548	1.254	0.172	0.0416	0.669	0.092	0.0436	0.611	0.084
2.8	0.0441	0.0493	1.298	0.166	0.0450	0.0572	1.310	0.167	0.0427	0.691	0.088	0.0448	0.630	0.080
2.9	0.0458	0.0512	1.349	0.160	0.0467	0.0595	1.369	0.163	0.0438	0.712	0.085	0.0460	0.649	0.077
3.0	0.0475	0.0531	1.402	0.156	0.0487	0.0617	1.426	0.158	0.0449	0.733	0.081	0.0472	0.668	0.074
3.1	0.0495	0.0550	1.458	0.152	0.0504	0.0637	1.484	0.154	0.0460	0.754	0.078	0.0484	0.687	0.071
3.2	0.0512	0.0567	1.515	0.148	0.0524	0.0656	1.543	0.151	0.0471	0.777	0.076	0.0497	0.706	0.069
3.3	0.0532	0.0585	1.572	0.144	0.0546	0.0676	1.600	0.147	0.0482	0.799	0.073	0.0510	0.726	0.067
3.4	0.0552	0.0600	1.628	0.141	0.0566	0.0693	1.657	0.143	0.0494	0.822	0.071	0.0523	0.747	0.065
3.5	0.0572	0.0613	1.688	0.138	0.0587	0.0707	1.714	0.140	0.0504	0.846	0.069	0.0537	0.767	0.063
3.6	0.0595	0.0626	1.744	0.135	0.0606	0.0721	1.773	0.137	0.0517	0.870	0.067	0.0551	0.787	0.061
3.7	0.0615	0.0638	1.802	0.132	0.0628	0.0734	1.829	0.134	0.0530	0.895	0.065	0.0567	0.806	0.059
3.8	0.0638	0.0650	1.860	0.129	0.0649	0.0744	1.888	0.131	0.0545	0.922	0.064	0.0583	0.826	0.057
3.9	0.0660	0.0659	1.919	0.126	0.0669	0.0751	1.946	0.128	0.0558	0.950	0.062	0.0600	0.846	0.056
4.0	0.0683	0.0668	1.980	0.124	0.0690	0.0757	2.003	0.125	0.0574	0.981	0.061	0.0618	0.865	0.054

TABLE 5
Faired Experimental Data at $\theta_r = -30$ deg.
(Diameter $2\frac{7}{8}$ -ft.)

J	C 2 × 2								F2			B2		
	-30°/-30°				-30°/-32°				-30°			-30°		
	k_{QP}	k_{QB}	k_s	S_c	k_{QP}	k_{QB}	k_s	S_c	k_q	k_s	S_c	k_q	k_s	S_c
0	0.0248	0.0252	0.209		0.0251	0.0275	0.213		0.0236	0.098		0.0238	0.100	
0.1	0.0250	0.0245	0.210		0.0254	0.0269	0.213		0.0242	0.107		0.0246	0.110	
0.2	0.0257	0.0240	0.213		0.0262	0.0267	0.219		0.0251	0.120		0.0254	0.123	
0.3	0.0270	0.0239	0.223		0.0276	0.0268	0.228		0.0266	0.133		0.0271	0.137	
0.4	0.0287	0.0240	0.241		0.0292	0.0272	0.248		0.0285	0.150		0.0289	0.154	
0.5	0.0304	0.0243	0.270		0.0310	0.0281	0.276		0.0308	0.170		0.0312	0.175	
0.6	0.0328	0.0251	0.304		0.0333	0.0294	0.312		0.0334	0.194		0.0339	0.199	
0.7	0.0351	0.0269	0.347		0.0357	0.0313	0.356		0.0369	0.223		0.0374	0.232	
0.8	0.0376	0.0292	0.392		0.0384	0.0337	0.403		0.0408	0.272		0.0413	0.276	
0.9	0.0403	0.0321	0.444		0.0412	0.0361	0.459		0.0434	0.315		0.0438	0.306	
1.0	0.0432	0.0357	0.505	0.505	0.0444	0.0393	0.522	0.522	0.0451	0.346	0.346	0.0455	0.331	0.331
1.1	0.0457	0.0400	0.571	0.472	0.0470	0.0431	0.590	0.488	0.0466	0.369	0.305	0.0470	0.352	0.291
1.2	0.0477	0.0443	0.636	0.442	0.0493	0.0476	0.653	0.453	0.0479	0.389	0.270	0.0486	0.371	0.258
1.3	0.0493	0.0483	0.698	0.413	0.0507	0.0520	0.713	0.422	0.0495	0.408	0.241	0.0502	0.387	0.229
1.4	0.0505	0.0518	0.753	0.384	0.0517	0.0567	0.769	0.392	0.0509	0.427	0.218	0.0519	0.401	0.205
1.5	0.0520	0.0551	0.805	0.358	0.0525	0.0608	0.820	0.364	0.0526	0.445	0.198	0.0536	0.414	0.184
1.6	0.0534	0.0581	0.853	0.333	0.0536	0.0644	0.864	0.338	0.0543	0.462	0.180	0.0553	0.427	0.167
1.7	0.0552	0.0609	0.895	0.310	0.0552	0.0674	0.902	0.312	0.0559	0.479	0.166	0.0571	0.441	0.153
1.8	0.0574	0.0636	0.930	0.287	0.0574	0.0688	0.927	0.289	0.0575	0.495	0.153	0.0588	0.455	0.140
1.9	0.0600	0.0649	0.961	0.266	0.0600	0.0688	0.965	0.267	0.0593	0.511	0.142	0.0604	0.470	0.130
2.0	0.0628	0.0653	0.986	0.246	0.0628	0.0690	0.986	0.246	0.0610	0.527	0.132	0.0622	0.485	0.121
2.1	0.0654	0.0650	1.001	0.227	0.0654	0.0698	1.001	0.227	0.0626	0.544	0.123	0.0639	0.500	0.113
2.2	0.0678	0.0670	1.028	0.212	0.0678	0.0711	1.028	0.212	0.0644	0.559	0.115	0.0656	0.516	0.107
2.3	0.0699	0.0686	1.072	0.203	0.0699	0.0737	1.072	0.203	0.0660	0.576	0.109	0.0673	0.532	0.101
2.4	0.0720	0.0713	1.120	0.194	0.0720	0.0773	1.120	0.194	0.0677	0.594	0.103	0.0691	0.549	0.095
2.5	0.0743	0.0756	1.170	0.187	0.0743	0.0816	1.170	0.187	0.0696	0.613	0.098	0.0708	0.565	0.090
2.6	0.0769	0.0800	1.220	0.180	0.0769	0.0864	1.220	0.180	0.0713	0.632	0.093	0.0726	0.582	0.086
2.7	0.0793	0.0842	1.271	0.174	0.0793	0.0912	1.271	0.174	0.0730	0.652	0.089	0.0744	0.599	0.082
2.8	0.0819	0.0880	1.320	0.168	0.0819	0.0956	1.320	0.168	0.0748	0.672	0.086	0.0762	0.617	0.079
2.9	0.0846	0.0918	1.371	0.163	0.0846	0.1000	1.371	0.163	0.0766	0.693	0.082	0.0781	0.633	0.075
3.0	0.0874	0.0952	1.422	0.158	0.0874	0.1038	1.422	0.158	0.0785	0.714	0.079	0.0800	0.650	0.072
3.1	0.0905	0.0988	1.473	0.153	0.0905	0.1076	1.473	0.153	0.0804	0.735	0.076	0.0819	0.668	0.070
3.2	0.0939	0.1018	1.524	0.149	0.0939	0.1110	1.524	0.149	0.0824	0.757	0.074	0.0840	0.685	0.067
3.3	0.0973	0.1050	1.576	0.145	0.0973	0.1143	1.576	0.145	0.0845	0.779	0.072	0.0861	0.702	0.064
3.4	0.1006	0.1080	1.627	0.141	0.1006	0.1172	1.627	0.141	0.0866	0.801	0.069	0.0883	0.720	0.062
3.5	0.1043	0.1106	1.678	0.137	0.1043	0.1198	1.678	0.137	0.0888	0.823	0.067	0.0906	0.737	0.060
3.6	0.1080	0.1133	1.730	0.133	0.1080	0.1223	1.730	0.133	0.0912	0.846	0.065	0.0929	0.754	0.058
3.7	0.1116	0.1156	1.781	0.130	0.1116	0.1245	1.781	0.130	0.0936	0.868	0.063	0.0955	0.772	0.056
3.8	0.1153	0.1178	1.831	0.127	0.1153	0.1264	1.831	0.127	0.0962	0.891	0.062	0.0982	0.790	0.055
3.9	0.1193	0.1197	1.883	0.124	0.1193	0.1281	1.883	0.124	0.0991	0.913	0.060	0.1012	0.807	0.053
4.0	0.1231	0.1212	1.935	0.121	0.1231	0.1296	1.935	0.121	0.1024	0.936	0.058	0.1048	0.825	0.052

(50952)

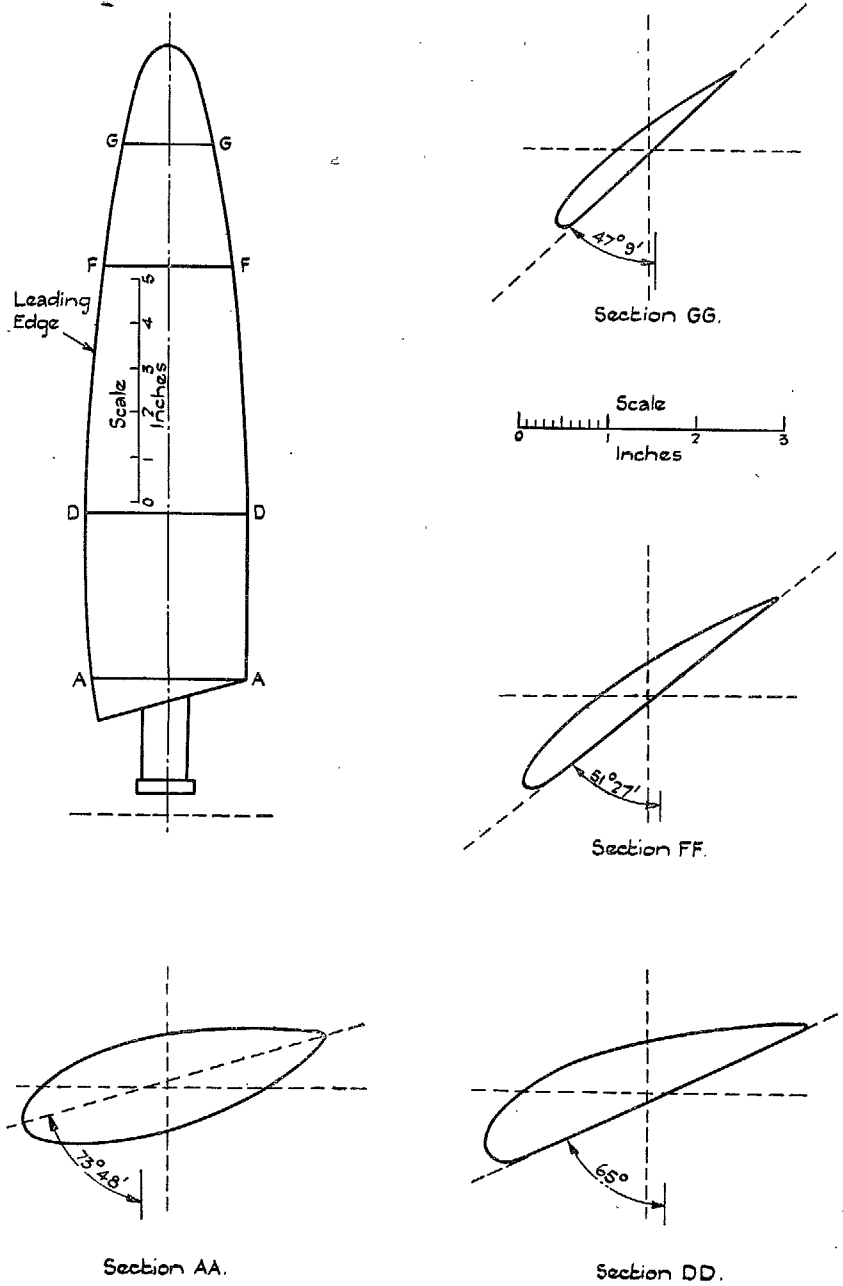

FIG. 1. Front Propeller ($2\frac{7}{8}$ -ft. Diameter). Blade Shape

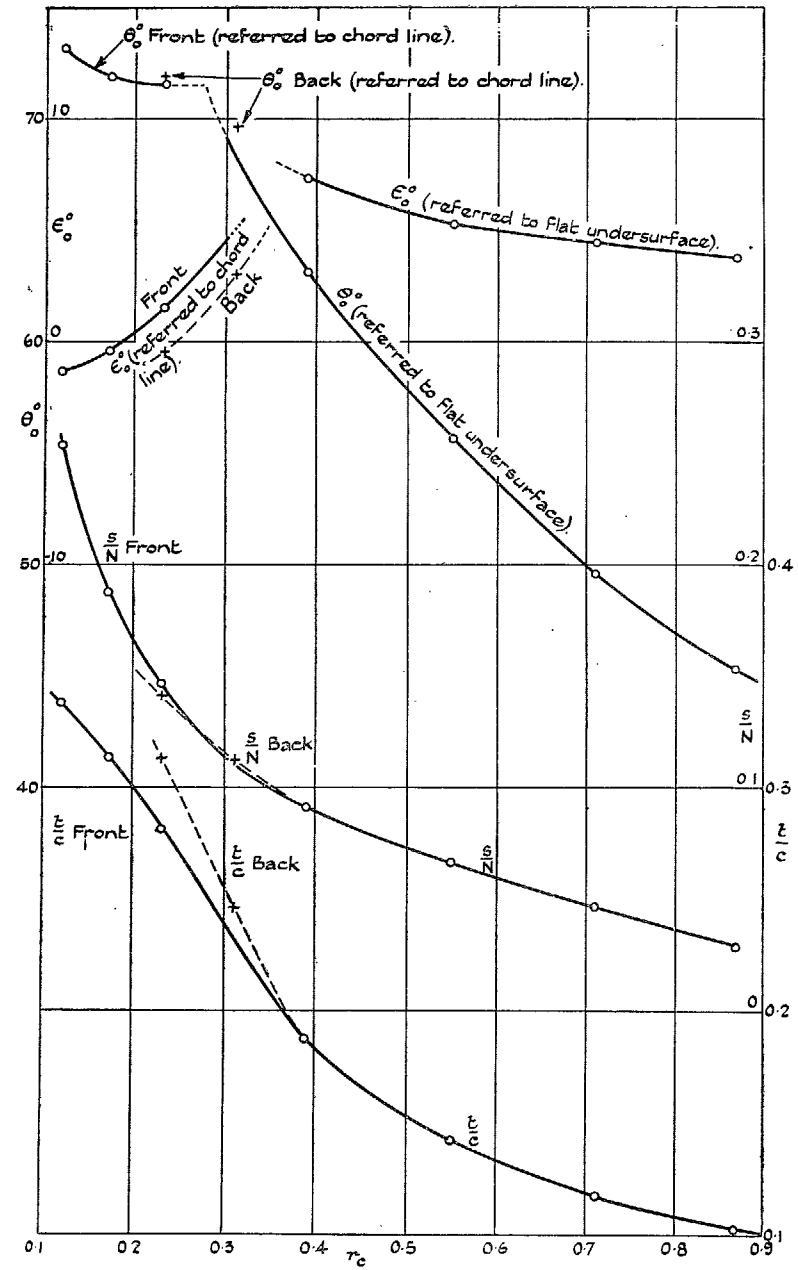

FIG. 2. Blade Data: θ_0 deg., ϵ_0 deg., s/N and t/c against r/c .

11

6

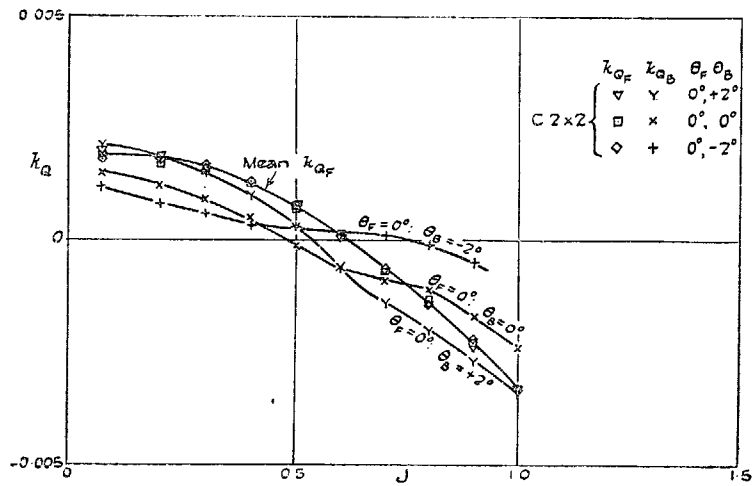

FIG. 3A. Torque Coefficients for Contra-rotating Propellers: $\theta_F = 0$ deg. (C 2 x 2: Diameter $2\frac{7}{8}$ -ft.)

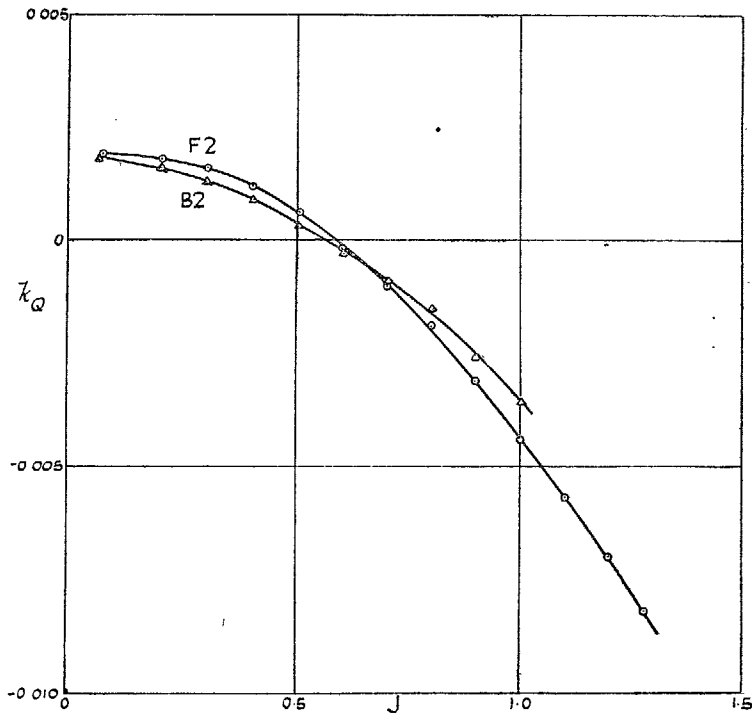

FIG. 3B. Torque Coefficients for Each Propeller Alone: $\theta = 0$ deg. (F2, B2: Diameter $2\frac{7}{8}$ -ft.)

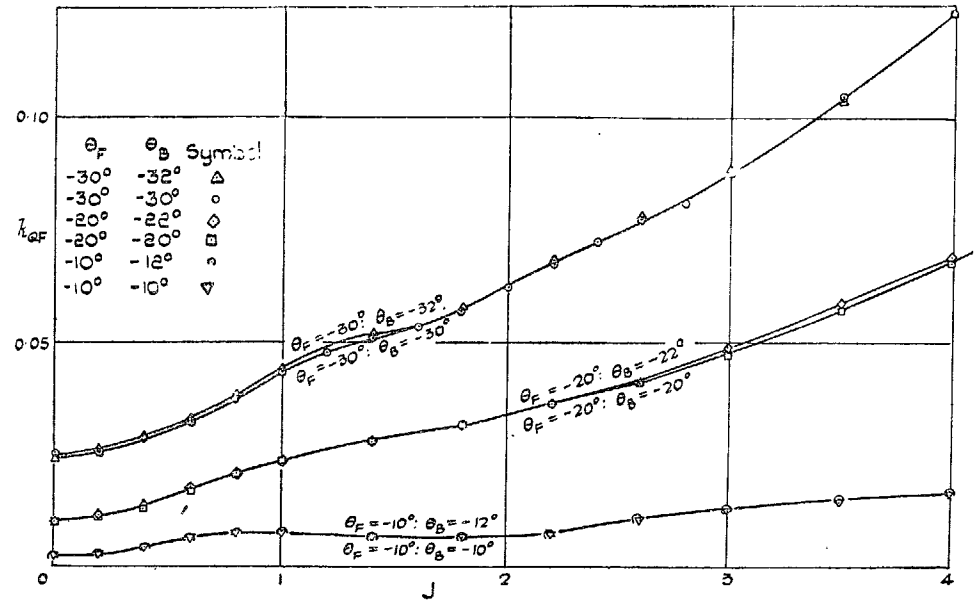

FIG. 4A. Torque Coefficients for Front Propeller of Contra-rotating Pair, at Various Blade Settings. (C 2 x 2: Diameter $2\frac{7}{8}$ -ft.)

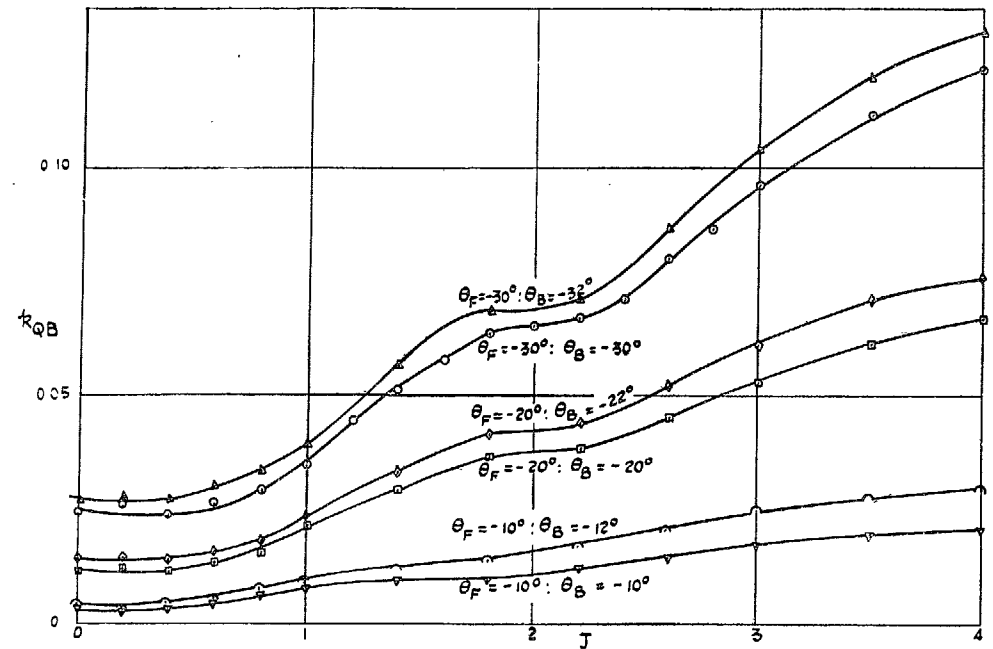

FIG. 4B. Torque Coefficients for Back Propeller of Contra-rotating Pair at Various Blade Settings. (C 2 x 2: Diameter $2\frac{7}{8}$ -ft.)

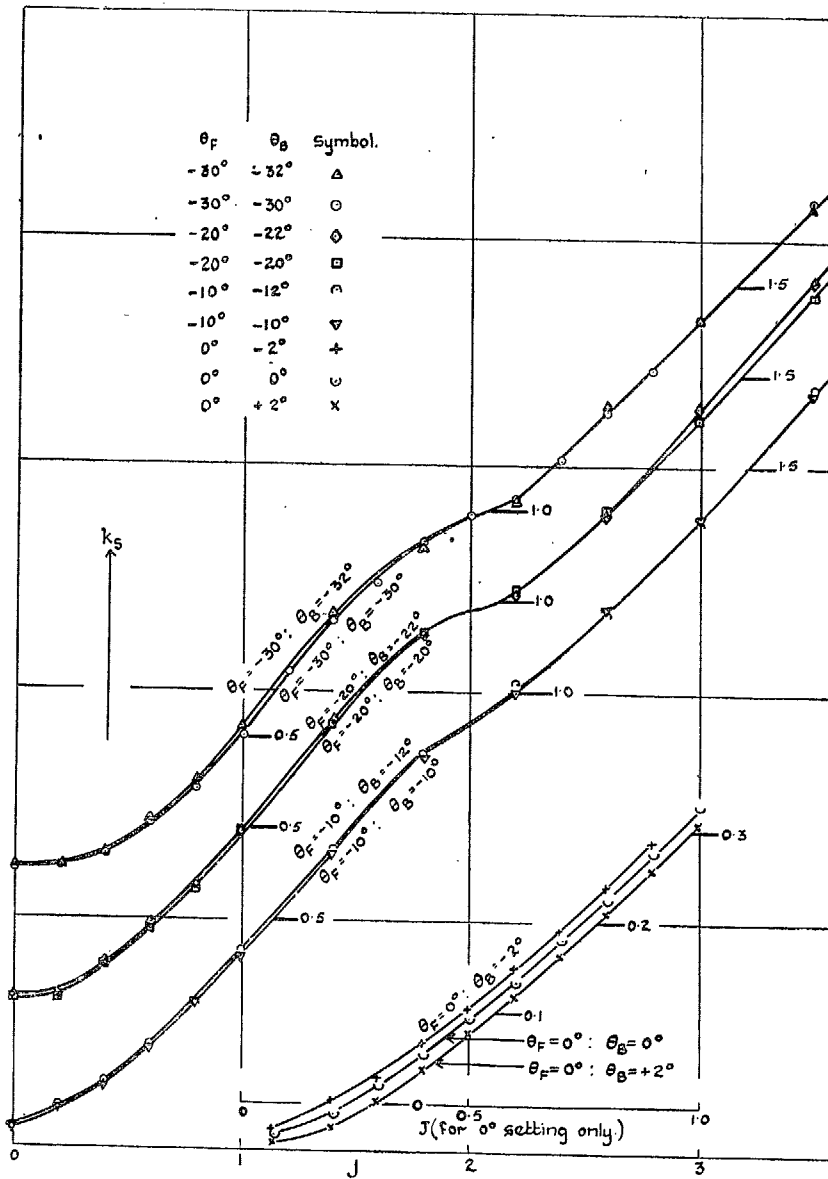

FIG. 5A. Braking Thrust Coefficient (k_s) for Contra-rotating Propellers at Various Blade Settings. (C 2 x 2 : Diameter 2 $\frac{7}{8}$ -ft.)

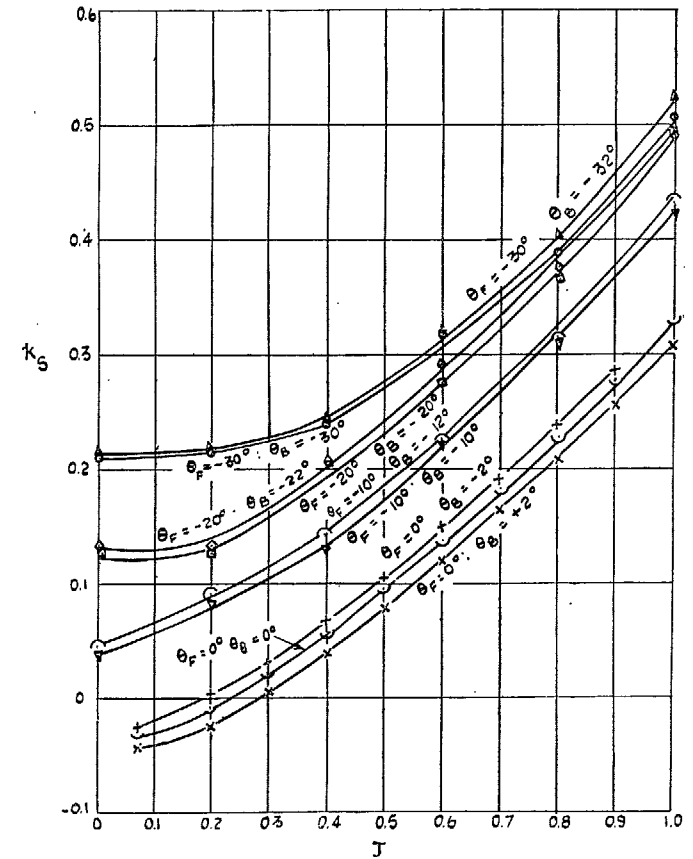

FIG. 5B. Braking Thrust Coefficient (k_s) for Contra-rotating Propellers at Various Blade Settings. (C 2 x 2 : Diameter 2 $\frac{7}{8}$ -ft.)

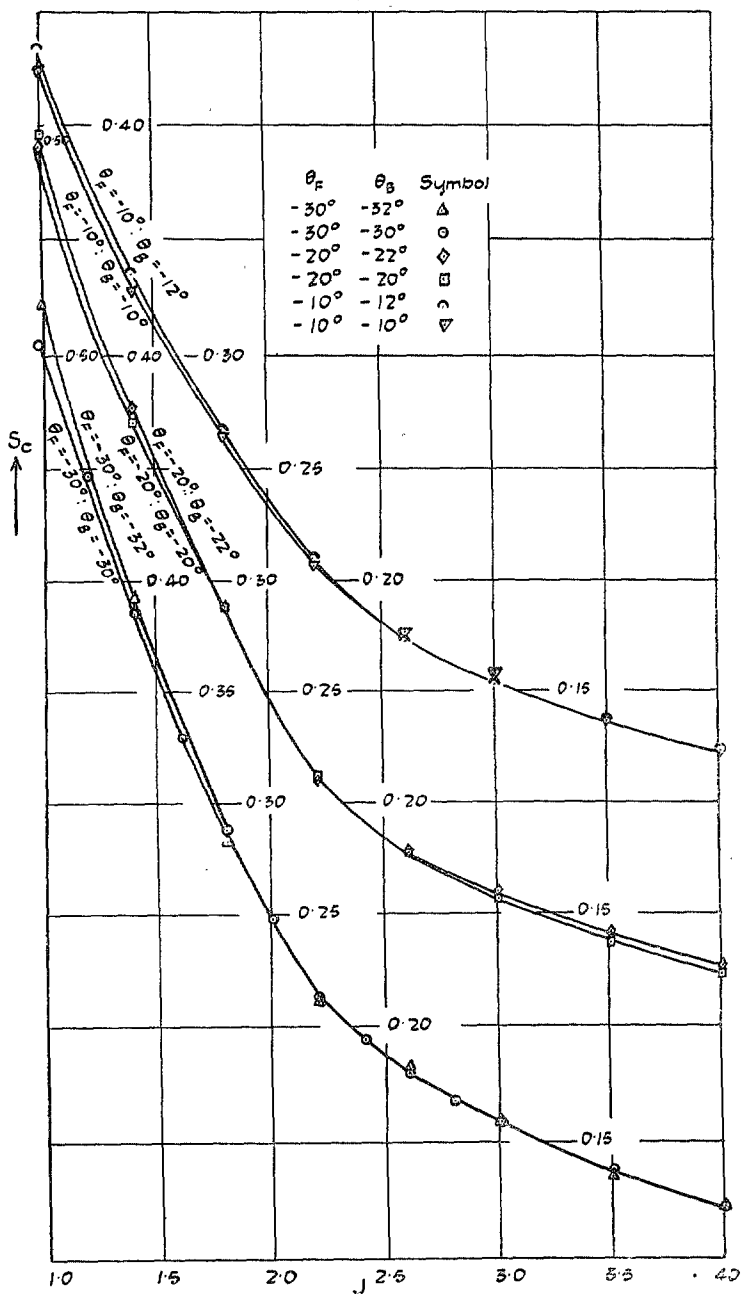

FIG. 6. Braking Thrust Coefficients (S_0) for Contra-rotating Propellers at Various Blade Settings. (C 2 x 2: Diameter $2\frac{7}{8}$ -ft.)

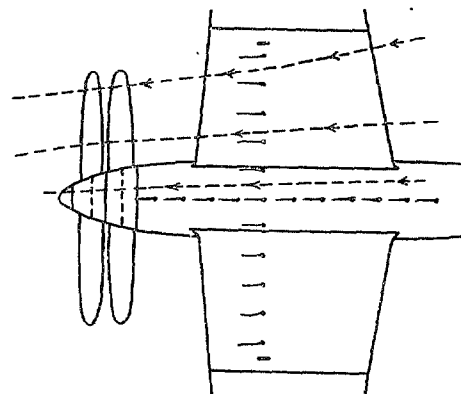
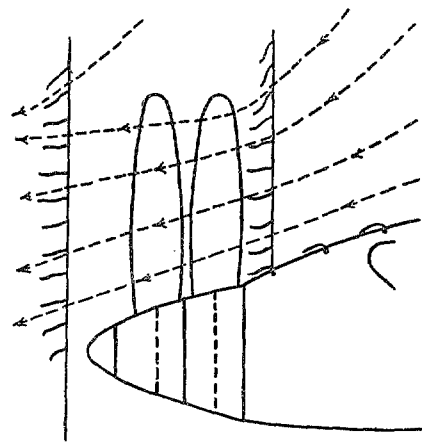

FIG. 7A. $J = 0$. Wool Tuft Explorations at Setting $-30^\circ / -30^\circ$. (C 2 x 2: Diameter $2\frac{7}{8}$ -ft.)

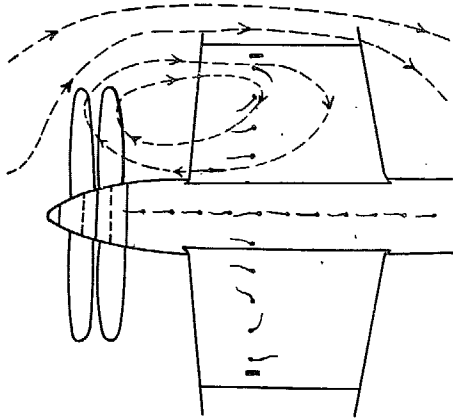
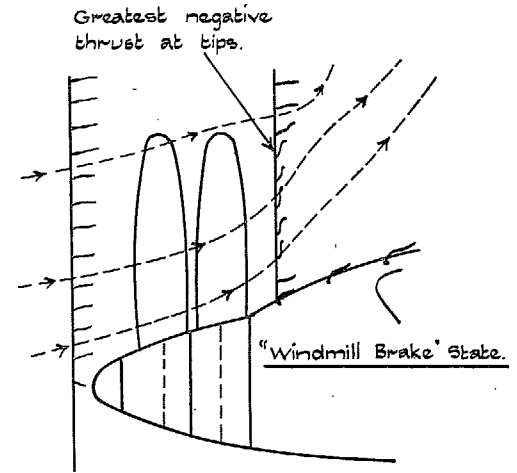
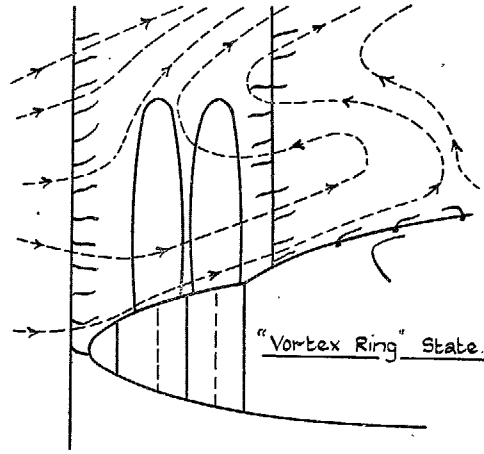
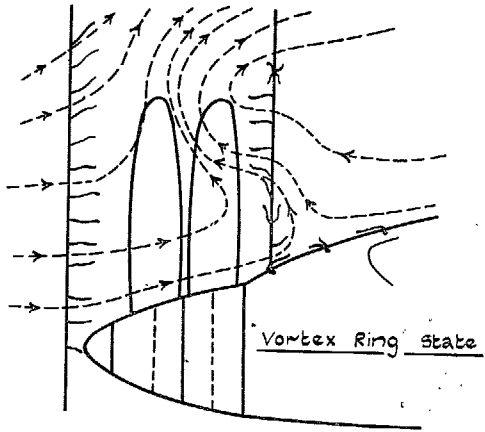

FIG. 7B. $J = 0.7$, $V = 25$ ft./sec.

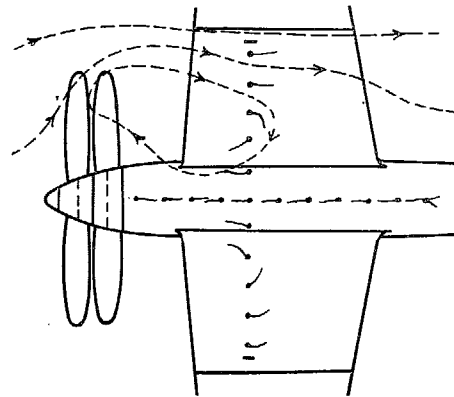

FIG. 7C. $J = 1.0$, $V = 30$ ft./sec.
Wool Tuft Explorations at Setting $-30^\circ/-30^\circ$.
(C 2 x 2: Diameter $2\frac{7}{8}$ -ft.)

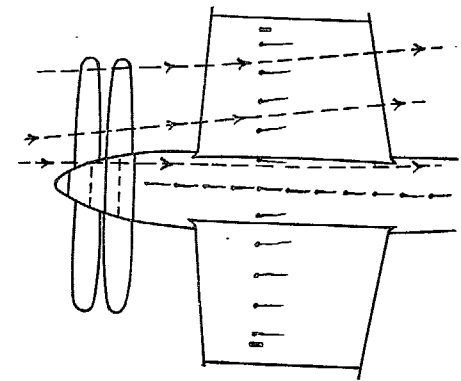

FIG. 7D. $J = 1.4$, $V = 45$ ft./sec.

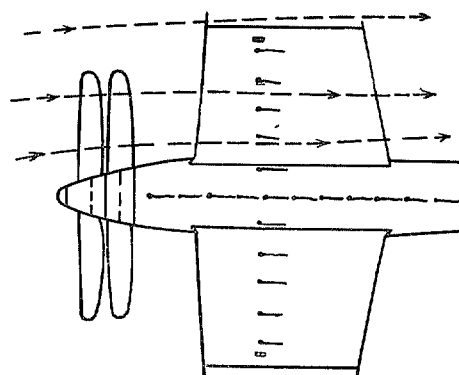
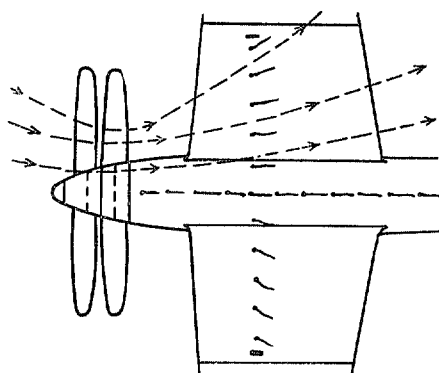
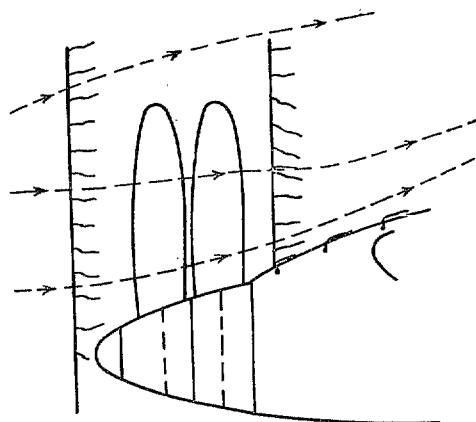
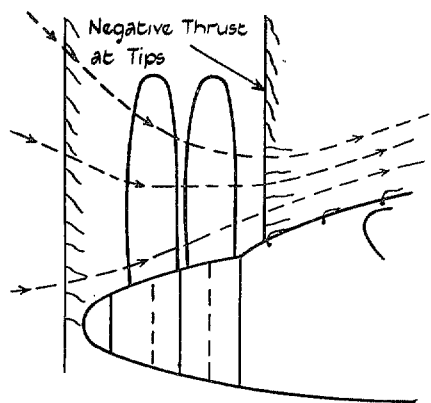

FIG. 8A. $J = 0$.

FIG. 8B. $J = 0.5, V = 25$ ft./sec.

Wool Tuft Explorations at Setting $0^\circ/2^\circ$.

(C 2 x 2: Diameter $2\frac{7}{8}$ -ft.)

Publications of the Aeronautical Research Committee

TECHNICAL REPORTS OF THE AERONAUTICAL RESEARCH COMMITTEE—

- 1934-35 Vol. I. Aerodynamics. 40s. (40s. 8d.)
Vol. II. Seaplanes, Structures, Engines, Materias, etc.
40s. (40s. 8d.)
- 1935-36 Vol. I. Aerodynamics. 30s. (30s. 7d.)
Vol. II. Structures, Flutter, Engines, Seaplanes, etc.
30s. (30s. 7d.)
- 1936 Vol. I. Aerodynamics General, Performance,
Airscrews, Flutter and Spinning.
40s. (40s. 9d.)
Vol. II. Stability and Control, Structures, Seaplanes,
Engines, etc. 50s. (50s. 10d.)
- 1937 Vol. I. Aerodynamics General, Performance,
Airscrews, Flutter and Spinning.
40s. (40s. 9d.)
Vol. II. Stability and Control, Structures, Seaplanes
Engines, etc. 60s. (61s.)

ANNUAL REPORTS OF THE AERONAUTICAL RESEARCH COMMITTEE—

- 1933-34 1s. 6d. (1s. 8d.)
1934-35 1s. 6d. (1s. 8d.)
April 1, 1935 to December 31, 1936. 4s. (4s. 4d.)
1937 2s. (2s. 2d.)
1938 1s. 6d. (1s. 8d.)

INDEXES TO THE TECHNICAL REPORTS OF THE ADVISORY COMMITTEE ON AERONAUTICS—

- December 1, 1936 — June 30, 1939
Reports & Memoranda No. 1850. 1s. 3d. (1s. 5d.)
July 1, 1939 — June 30, 1945
Reports & Memoranda No. 1950. 1s. (1s. 2d.)

Prices in brackets include postage.

Obtainable from

His Majesty's Stationery Office

London W.C.2: York House, Kingsway
[Post Orders—P.O. Box No. 569, London, S.E.1.]

Edinburgh 2: 13A Castle Street
Cardiff: 1 St. Andrew's Crescent

Manchester 2: 39-41 King Street
Bristol 1: Tower Lane

Belfast: 80 Chichester Street
or through any bookseller.