

N.A.E.

NATIONAL AERONAUTICAL ESTABLISHMENT
LIBRARY

R. & M. No. 2597
(11,159)
A.R.C. Technical Report



MINISTRY OF SUPPLY

AERONAUTICAL RESEARCH COUNCIL
REPORTS AND MEMORANDA

An Examination of the Technique of
the Measurement of the Longitudinal
Manoeuvring Characteristics of an
Aeroplane, and a Proposal for a
Standardised Method

By

D. J. Lyons, B.Sc. (Eng.)

Crown Copyright Reserved

LONDON: HER MAJESTY'S STATIONERY OFFICE

1952

SIX SHILLINGS NET

An Examination of the Technique of the Measurement of the Longitudinal Manoeuvring Characteristics of an Aeroplane, and a Proposal for a Standardised Method

By

D. J. Lyons, B.Sc. (Eng.)

COMMUNICATED BY THE PRINCIPAL DIRECTOR OF SCIENTIFIC RESEARCH (AIR)
MINISTRY OF SUPPLY

*Reports and Memoranda No. 2597**

September, 1947

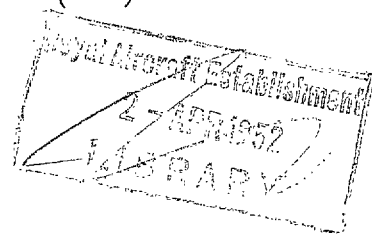

Summary.—It is demonstrated in this report that the 'steady stick force per g ' as defined by Gates and Lyon in R. & M. 2027⁴ is the best criterion for the measurement of manoeuvrability of an aircraft because:—

(a) practically, it indicates the minimum stick force that has to be exerted by the pilot to break the aircraft, and (b) its value is obtainable in flight by a perfectly definite test procedure.

It is further concluded that some additional criterion may be necessary to ensure that unduly heavy forces are not encountered during sharp pull-outs.

A method of measuring the steady stick force per g , has been developed at the Royal Aircraft Establishment which it is suggested should be standardised for such tests throughout the country. The results of this method have been demonstrated on two aircraft, a Mosquito and a Lancaster.

1. *Introduction.*—The quantity, stick force per g , (and to a lesser extent the quantity 'elevator or stick movement per g ') has become generally accepted to be an important characteristic in determining or expressing the handling qualities of an aircraft in the pitching plane, and most comprehensive schedules of flight requirements such as Refs. 1, 2, 3, include a requirement as to the limits of the values of the stick force per g for the particular aircraft types considered. This natural drift towards a fuller understanding and measurement of the manoeuvring characteristics of the aircraft has been strengthened by a theoretical report by Gates and Lyon⁴. In this report, it is indicated that a knowledge of these manoeuvring characteristics is, perhaps, more essential than a knowledge of the static stability characteristics in assessing or predicting the handling qualities of an aircraft, though it is, of course, necessary to study all these characteristics to obtain a full understanding of the handling of the aircraft in the pitching plane.

When we come to examine the problem of the actual measurement of the manoeuvring characteristics in flight, however, we find the position not too satisfactory. In this country we have been measuring static margins and neutral points for some years. Since the flight technique and analysis is simple (at least at low and cruising speeds before distortion or compressibility effects become significant), and follows the theoretical treatment fairly exactly, little difficulty has been encountered. On the other hand, though scientific definitions of the manoeuvring characteristics have been outlined, it is impossible to make a practical measurement strictly along these lines, and, in addition, all attempts to obtain a rational and practical measurement of these characteristics require some considerable degree of skill on the part of the pilot.

* R.A.E. Report Aero 2223—15th January, 1948

These difficulties have led to a certain amount of confusion in the methods of measurement throughout the various research establishments and aircraft firms, some attempting to obtain measurements approximating to the scientific definitions, and others using methods which enable simpler flight techniques to be used. The unfortunate outcome of this, is that when the term stick force per g is used, it is not immediately apparent what exactly is meant, for if we crudely define stick force per g as the increment in force divided by the increment in g , the method of test and measurement may have a profound effect on its numerical value. This is obviously an unsatisfactory state of affairs, and this report has been prepared in order to view the whole problem, particularly from the practical angle. The various methods of measurement used are discussed, and a technique of measurement which has been developed at the Royal Aircraft Establishment is put forward as a suggested standard method, suitably adapted to routine or research tests. This suggested method has been demonstrated on two aircraft, a Lancaster and a Mosquito, and the results are presented and briefly discussed.

2. *The Scientific Definitions of the Steady Manoeuvring Characteristics in Pitch.*—Proposals for the establishment of criteria for the manoeuvring characteristics of an aircraft in pitch were outlined in Ref. 5 by Gates, and since then Gates and Lyon have set down more fully in R. & M. 2027⁴ the mathematical analysis of the longitudinal manoeuvring characteristics. In these reports it is suggested that the manoeuvrability of the aircraft should be assessed by the changes in elevator angle and stick force, when the pitching velocity is changed by an amount equivalent to an increase in the normal loading of the aircraft by '1g,' all other motions of the aircraft remaining unaltered. The six main quantities by which the manoeuvrability can then be expressed are:—

(a) *The stick force per g*—defined as the *steady* change in stick force to produce a *steady* increment of g in the normal acceleration of the aircraft, whilst the aircraft is moving in a vertical circle, with the normal component of the aircraft weight, the speed and the pressure height all remaining constant.

(b) *The elevator angle per g*—defined as the *steady* change in elevator angle to produce a *steady* increment at 1 g in the normal acceleration of the aircraft under the same conditions as (a).

(c) *The stick free manoeuvre point (h_m')*—defined as the C.G. position at which the stick force per g as defined in (a) becomes zero.

(d) *The elevator fixed manoeuvre point (h_m)*—defined as the C.G. position at which the elevator angle per g as defined in (b) becomes zero.

(e) *The stick free manoeuvre margin (H_m')*—defined as the distance between the stick free manoeuvre point and the C.G. in chord lengths.

(f) *The elevator fixed manoeuvre margin (H_m)*—defined as the distance between the elevator fixed manoeuvre point and the C.G. in chord lengths.

Bearing in mind the relationship between these six quantities, we will in the main hereafter in this report confine the discussion to the quantity stick force per g .

The definitions as they stand are not strictly practical since they all refer to a change in pitching velocity only, whereas in practice in a steady pull-out in a vertical circle there must be a change with time of both the direction of the gravity field and the airspeed, when the g on the aircraft is altered from unity. This was, of course, pointed out by Gates and Lyon, but they suggested that in practice the assumptions as to the pure pitching motion would be approximately valid, as long as the flight path did not depart too far from the horizontal, and that under this condition, the theoretical and practical values of the stick force per g would be equal.

3. *The Value of the Manoeuvrability Criteria as Measured in Steady Pull-outs and a Discussion of the Stick Force per 'g' in Other Steady and Unsteady Forms of Flight.*—First, quite obviously, the value of the stick force per g in a steady pull-out is a measure of

(a) the manual force the pilot has to exert to manoeuvre his aircraft when under a steady acceleration in a pull-out to the particular normal loading that is required of the type,

(b) the manual force the pilot has to exert in order to hold the value of the normal acceleration on the aircraft that is sufficient to break the wings in the same manoeuvre as (a), (this assumes linearity of the values of the hinge moment parameters over the ranges used in the pull-out.). This is generally true except at the lower end of the speed range when the stall is approached or reached and it is fairly clear that for any given type of aircraft (without any devices, such as g restrictors, fitted which make the g , stick force curve non-linear), it is possible to select a range of values for the stick force per g such that it is difficult for the pilot to break the aircraft during a steady pull-out, without making it completely impossible for him to manoeuvre the aircraft in such a manner as is required of the type¹. There are additional factors that must be brought into this selection, such as the blackout threshold of the pilot, and the relationship between the breaking g and the desirable manoeuvring g .

The problem of selecting the best range can be most difficult especially when the desirable manoeuvring g approaches the breaking g of the wings, as it may easily do on a large military aircraft. In these cases, it has been usual to base the selection mostly on considerations of safety, and this results in relatively heavy loads for normal manoeuvring.

It is evident, however, that these steady criteria, based on steady and established manoeuvres, will not generally bear any direct relationship to the characteristics during unsteady manoeuvring or in steady turning flight, etc. Let us examine briefly this relationship in three typical cases—

- (1) a rapid elevator movement of sinusoidal form,
- (2) the initiation of a pull-out,
- (3) steady turning flight with bank.

3.1. *A Rapid Elevator Movement of Sinusoidal Form.*—An analysis of the effects on the aircraft and stick forces of a rapid elevator movement of sinusoidal form has been given in Ref. 6, by Jones and Greenburg. They have evaluated, for a few spot values of B_1 , B_2 and weight moment in the elevator circuit, the change in normal acceleration and stick force for such a sinusoidal pulse of elevator angle on a typical fighter aeroplane. The wing loading of the fighter was 30 lb/sq ft, the μ_1 was 23 and the C.G. was at 3 different positions, such that the H_m varied from 0.06 to 0.12; flight speed was 400 m.p.h. E.A.S.

The form of elevator angle movement assumed was as depicted in the sketch below:—

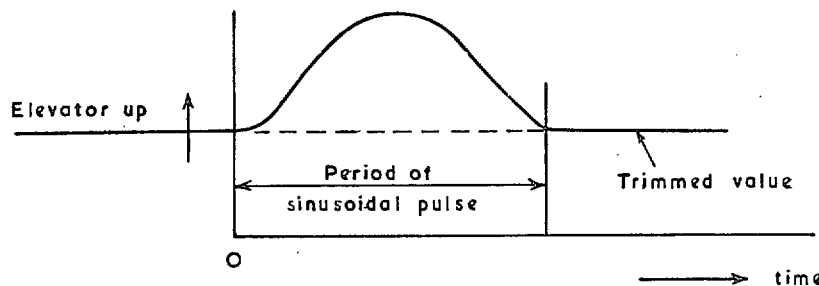

This work has been extended in the present report to cover, for this fighter type, the whole likely range of B_1 and B_2 values, and the results plotted in a different form. Here the difference between the peak stick force per g and the steady stick force per g has been evaluated for each case and plotted as a function of B_1 and B_2 (the peak stick force per g is defined as the maximum *pull* force exerted by the pilot on the control column during the whole manoeuvre until steady conditions are re-established divided by the maximum g recorded). The results of these calculations are shown in Figs. 1 to 5.

Also included in these figures are the lines of constant, steady stick force per g values, and the areas for which negative (*i.e.*, push) forces as well as positive (pull) forces occur during the complete manoeuvre. The figures are a little complicated, but can readily be understood if one realises that, given the constant conditions listed on the right-hand side of the figure, any two of the following quantities are sufficient to determine the remaining two—

- (a) B_1 ,
- (b) B_2 ,
- (c) steady stick force per g ,
- (d) the difference between the peak stick force per g and the steady stick force per g .

Thus each position on the figure represents a unique value of all four quantities. The area of each figure in which we are interested practically will be determined by the value of the *steady* stick force per g , say for this particular aircraft broadly between -10 lb per g and $+30$ lb per g .

Examination of these figures will show that:—

(a) Even for the extremely rapid elevator movement of period 1 second, without inertia weight the peak stick force per g is never lower (for the cases considered) than the steady stick force per g by more than 1 lb, and even with an extremely large inertia weight, equivalent to 15 lb per g , this figure is only increased to $2\frac{1}{2}$ lb. Without inertia weight, smaller peak stick forces per g than the steady stick force per g will only occur also so long as

- (i) the period of the sinusoidal pulse is small, *i.e.*, < 2 sec, at 400 m.p.h. E.A.S.,
- (ii) the B_2 is small, and B_1 is positive, *i.e.*, roughly, $-B_1/B_2 > 1.0$.

This last condition represents a very large stability gain on freeing the stick, at least $0.07\bar{c}$; and as requirements are now being framed to limit this gain to $0.05\bar{c}$, this condition is therefore unlikely to be encountered, especially with large tail volumes. The inertia weight considered is, of course, extremely large for a fighter type.

(b) The effect of a large reduction in H_m ($\Delta H_m = 0.06$) is either very small or in the direction to make peak stick force per g still larger than the steady stick force per g (*i.e.*, for the same B_1, B_2 values).

(c) For a practical control, *i.e.*, $-B_2 > 0.05$, inertia weight effect not greater than 6 lb per g , and the steady stick force per g not greater than 20 lb, even with fast elevator movement the peak stick force per g is not likely to be less than the steady stick force per g by more than $\frac{1}{2}$ lb per g , and it will, in general, be higher, possibly by up to 10 lb per g .

It is important to note here that as the period of the elevator pulse tends to zero, the peak stick force per g tends to infinity; this is clear, for with an infinitely fast pulse of finite magnitude there will be no aircraft response, and therefore no increase in normal acceleration, but there will be a large peak force mainly from the elevator damping (ignoring elevator inertia as we have been doing).

.Now in some cases, we have shown that, dealing with relatively large periods of the elevator pulse (*i.e.*, ≥ 1 sec), the peak stick force can decrease as the period of the pulse is reduced. For these cases, therefore, a minimum value of the peak stick force per g will occur at some small finite value (*i.e.*, < 1 sec) of the pulse period. This is shown experimentally in Ref. 7.

Next it can be inferred from a study of the basic equations of motion that

(a) if the product of the speed and duration of the elevator motion is held constant the shape of the individual stick force and g curves is unaltered, and the resultant peak stick force per g curves are unaltered in shape and magnitude.

(b) the effect of alteration in the maximum elevator angle for a given period of elevator pulse on the peak stick force per g curves is zero.

To illustrate the effect of size of the aircraft, some additional calculations have been made of the effect of reducing μ_1 to 12 keeping geometrical similarity, except that elevator area and chord were reduced to a practical size for the larger aircraft. This size of aircraft considered is roughly that of the Lancaster. The methods used in the calculations were the same as those given in Ref. 6 and the results are given in Fig. 6 for the following conditions

- (i) an $H_m = 0.12$,
- (ii) a period of the sinusoidal pulse of elevator angle of 2 sec,
- (iii) a forward aircraft speed of 200 m.p.h. E.A.S.

This case represents a relatively fast application compared with the cases considered for the fighter type, but nevertheless it is a very practical case for the heavy aircraft. It will be seen from this figure that no practical B_1 and B_2 values will give lower peak stick forces per g than the corresponding steady stick forces per g , but the peak stick force per g may be much larger than the steady stick force per g by up to 100 lb per g in quite practical cases.

It is considered that these cases are sufficient to show that during a sinusoidal pulse of elevator angle

(i) the peak stick force per g will, in general, be higher than the steady stick force per g by very considerable amounts, though as the time of the manoeuvre increases the difference will get smaller,

(ii) for a certain range of the period of the manoeuvre, depending upon the value of B_1 and B_2 , size speed, etc., it is just possible that the peak stick forces per g may be lower than the steady stick forces per g , though by a very small amount in any cases which are liable to occur in practice. This effect is unlikely to occur often, however, for the conditions necessary, *i.e.*, a large negative B_1/B_2 or a large inertia weight are not acceptable due to other considerations. An attempt to improve the stability by means of the inertia weight is perhaps the likeliest cause of the occurrence. A recent report, Ref. 7, on this point suggests moreover that a smaller stick force per g in rapid manoeuvres than in the steady manoeuvre is in itself objectionable and is being prohibited in recent American requirements.

3.2. *The Initiation of a Pull-out.*—If a pilot wishes to change the longitudinal direction of the flight path of an aircraft, not in a sudden pull-up of short duration as discussed in the last sub-paragraph, but in a more or less steady manoeuvre, then the 'pull-out' or 'push-in' can, in general, be divided into three sections:—

- (a) entry and settling down,
- (b) the steady manoeuvre until the approximate change of flight path angle desired is obtained,
- (c) the exit and settling down to the steady flight at the new angle of the flight path.

The section (b) is covered by the steady manoeuvring characteristics already discussed as long as the flight path is approximately horizontal (for other conditions *see* section 4.2, where this is discussed); sections (a) and (c) are identical for our purpose, both being transitional stages from one state of steady normal acceleration to another, so we will confine the argument to one, (a), namely the initiation of the pull-out.

Now the pilot's actual stick movements during the entry are somewhat problematical, and it is evident that they must vary from one pilot to another and from one pull-out to another, but, provided he is not using violent movements as considered in the last sub-section, it is thought that a reasonable approximation to an average entry can be obtained by assuming that

the pilot moves his controls in such a manner that the angular acceleration of the aircraft is constant until such time as the desired g is approached. (There will, of course, be periods at the beginning and end of the initiation during which the angular acceleration, \dot{q} , is being built up or reduced.) The value of \dot{q} will depend upon the wish of the pilot for a slow or fast entry.

It can be shown that, ignoring elevator inertia effects and aero-dynamic damping of the elevator, the stick force at any time during the initiation will be approximately equal to

$$- m_e \frac{B_2}{A_2 \bar{v}} \frac{W}{S} \cdot S_\eta c_\eta \left(n H_m' + \frac{i_b l^2}{g \bar{c}} \dot{q} \right).$$

The first term in the expression represents the value of the stick force in a steady pull-out, at the instantaneous value of ng reached at the time considered. The second term is dependent on the geometry of the aeroplane, the value of B_2 and the \dot{q} only. Now it is evident that as the value of $H_m' \rightarrow 0$, the pilots force during the initiation of the pull-out will only consist of the second term, and as the pilot reaches the desired value of n , he will have to reduce the value of \dot{q} to zero and so his stick force will return to zero (or the trimmed value); thus a peak in the stick force will occur during the initiation. In practice, this peak will even occur with small negative values of H_m' , as appreciable elevator movement is needed to commence the pull-out before the pull stick force due to the negative H_m' provides the force necessary to produce a reasonable \dot{q} . Now let us consider the case when the value of H_m' is such that the first term is of the same order as the second term or much larger. The actual stick force will be larger than the steady stick force at the instantaneous value of n by the value of the second term, but as the pilot approaches the desired value of n , he is now able to hold a constant stick force and let the increase in the stick force due to the rise of n in the first term gradually reduce the second term and so reduce the value of \dot{q} gradually to zero, equilibrium being obtained at the desired value of n . Therefore, there is no need for a peak to occur in the stick force in these conditions, unless the pilot sharply reverses the control as the desired value of n is reached.

We might expect therefore in practice that

(a) the peak stick force measured during a pull-out of this nature with any possible H_m' values will always be greater than the steady stick force per g ,

(b) with large H_m' values the difference between the peak and steady stick force per g will be small or negligible,

(c) with small H_m' values the difference will increase, the difference depending approximately, other than on geometry, on the value of B_2 and the maximum value of the pitching angular acceleration.

3.3. *Steady Turning Flight.*—An analysis of the stick forces during steady turning flight is given in R. & M. 2027^A; in this report it is shown that the increment in stick force from the straight flight to the steady turn at the same forward speed is given by:—

(Equation 108 of R. & M. 2027^A)

$$\Delta \bar{P} = - m_e \frac{W}{S} S_\eta c_\eta \frac{B_2 n}{A_2 \bar{v}} \left[H_m' + \frac{\bar{V} \bar{A}_1}{2\mu_1 \bar{n}} - \frac{l}{\bar{c}} \frac{C_{L\gamma_s}}{2\mu_1} (i_c - i_a) \left(1 + \frac{1}{n} \right) \right]$$

where $\Delta \bar{P}$ is the mean change in stick force, in left-hand and right-hand turns, due to an increase of ng in the normal acceleration.

Now the first term in this equation, *i.e.*,

$$- m_e \frac{W}{S} \cdot S_\eta c_\eta \frac{B_2 n}{A_2 \bar{v}} \cdot H_m'$$

is the change in steady stick force in a vertical circle due to ng change in the normal acceleration.

Therefore, the difference between the stick force per g in turning flight and the steady stick force per g is

$$- m_e \frac{W}{S} \cdot S_\eta c_\eta \frac{B_2}{A_2 \bar{v}} \left[\frac{\bar{V} \bar{A}_1}{2 \mu_1 \bar{n}} - \frac{l}{\bar{c}} \cdot \frac{C_{L\gamma_s}}{2\mu_1} (i_c - i_a) \left(1 + \frac{1}{\bar{n}} \right) \right]$$

Now the second term in this expression is usually small and vanishes for a level turn, *i.e.*, the expression becomes

$$- m_e \frac{W}{S} \cdot S_\eta c_\eta \frac{B_2}{A_2} \frac{\bar{a}_1}{2 \mu_1 \bar{n}} \text{ in level flight.}$$

In Fig. 7, the values of this quantity are plotted against the value of \bar{n} for a range of values of B_1 and B_2 for the fighter of Ref. 6, used in the previous calculations and a scale approximately applicable to the heavy aircraft of Fig. 6 is appended. It is seen that the stick force per g in the steady level turn is greater than that in the straight pull-out unless B_2 is small, *i.e.*, < 0.1 , and in addition B_1 is negative and large, *i.e.*, of the order -0.2 . In practice this combination is very unlikely to be used, because the large positive value of B_1/B_2 means that considerable stability will be lost on freeing the stick (probably between 0.2 and $0.5\bar{c}$). It will further be seen from Fig. 7 that the difference in the stick forces per g obtained by the two methods falls off rapidly as the total g on the turn is increased, but even at $4.0 g$, which probably represents the limits of accurate flying in the steady turn, this difference may amount to between 1 and 3 lb in a practical case for the fighter type considered, a very significant amount when one considers that the desirable stick force per g on a fighter may lie between 3 and 8 lb per g . On the heavy aircraft considered (about Lancaster size) on which it is unlikely that $2g$ will be exceeded in tests to determine the stick force per g , the difference may amount to up to 50 lb per g .

Fig. 7 also demonstrates how an aircraft may need a positive (pull) force to produce small normal accelerations in a turn, whilst on the other hand at large normal accelerations a push force is required to stop the turn from tightening up. For instance, if we consider a fighter say with a B_2 of -0.3 and a B_1 of 0, but with a stick force per g in the steady pull-out of -2 lb per g , it is evident that below approximately 4.5 normal g a pull force is required to trim, but above that figure a push force is required to prevent self tightening of the turn.

It is of interest to note that on tailless aircraft, by virtue of their lower m_q , the differences between the stick force per g in the turn and in steady pull-out are much smaller, and may even be ignored for a large range of geometry and aerodynamic characteristics. Each case should, however, be examined before assuming this simplification is justified.

Now, summarising the points of the last three sub-sections:—

(1) The peak stick force per g measured during the three types of manoeuvres discussed is only less than the steady stick force per g in a straight pull-out in very exceptional circumstances; for the sharp pull-out it only occurs when either the value of B_1/B_2 is very negative or a large inertia weight is fitted. For the steady turn it only occurs when the value of B_1/B_2 is large and positive. All these conditions are objectionable on other grounds but it is just possible that they may occasionally happen in practice. The difference between the steady stick force per g and the peak stick force per g will always be relatively small in these conditions and almost certainly within the experimental scatter.

(2) In the large majority of cases, the peak stick force per g will be larger than the steady stick force per g by up to 10 lb per g say for a fighter, and 100 lb per g for a heavy aircraft (Lancaster size).

It is argued from these considerations that the value of the steady stick force per g will, in general, indicate the least stick force, within experimental scatter, with which a certain normal acceleration, say the limiting g from structural considerations, can be obtained even in unsteady

conditions, and this is the best guide to the suitability of an aircraft from the safety aspect. It also appears possible that in certain cases, the large increase in the stick forces needed to produce a certain value of the normal acceleration in unsteady conditions or in a steady turn compared with that needed in the steady pull-out, may be objectionable to the pilot, and that a new requirement limiting this difference may be desirable.

4. *The Measurement of the Manoeuvring Characteristics of an Aircraft in Pitch.*—As pointed out in the previous sections, the main doubts which beset the flight test technicians and pilots when undertaking manoeuvrability tests of the aircraft in pitch are

(a) it is impossible to make a test which gives values of the manoeuvring characteristics *strictly* along the lines of the theoretical suggestions of R. & M. 2027⁴,

(b) the steady manoeuvring characteristics do not necessarily give an indication of the perhaps 'more real' behaviour of the aircraft in unsteady flight or turning flight,

(c) it is difficult to provide the pilot with a perfectly definite test procedure which will always give the same results (measurements in steady turning flight are an exception to this).

Because of these difficulties many test procedures have been contrived, some seeking to obtain a result in near agreement with the theoretical steady stick force per g , some taking the simplest technique from the piloting angle and some trying to obtain some measure of the 'real life' behaviour of the aircraft in dynamic flight. Now let us examine the pros and cons of the various methods which have been used in practice.

4.1. *Peak Stick Force per g Measurements During a Normal Vertical Pull-out.*—This method aims at achieving an estimate of the real life stick force per g in a normal manoeuvre. The pilot is asked to do a normal pull-out and the stick force per g is defined as the peak stick force during the pull-out/peak g during the pull-out, the peaks being conveniently obtained by maximum reading instruments.

The main faults with this method are as follows:—

(a) It is difficult to define a normal pull-out; it may either fall into the category of the sharp pull-up of section 3.1 or may be a manoeuvre such as dealt with in section 3.2, and, as has been discussed in these sections, the peak stick force per g may depend critically on the rapidity of the manoeuvre. Even if a definition was decided upon, the difficulties of pilots in attempting to follow the definition are obvious, as control rates of movement would have to be specified to get strictly repeatable answers.

(b) As pointed out in sections 3.1 and 3.2, the stick forces per g will very often not indicate the minimum stick force necessary to apply a given g to the aircraft. This will especially be true when the value of H_m' is low and the safety aspect of the aircraft may be critical; the danger of recording by this method in these conditions a stick force to reach the limiting g , which is much greater than the minimum, is obvious.

The one advantage of this method is that it could be used to find out if there was an unacceptable increase of the peak stick force per g with quick manoeuvres. It is apparent, however, that piloting difficulties would prove to be a serious obstacle to its use for this purpose, though extensive instrumentation would mitigate these difficulties.

4.2. *The Normal Method.*—This method is the straightforward one for attempting to obtain a measure of the steady stick force per g in a vertical pull-out corresponding approximately to the theoretical definition, the following technique being used:—

The aircraft is trimmed out at a chosen forward speed and then a pull-out is commenced slowly and steadily from this trimmed state; when the chosen g is reached, the pilot attempts to hold this value constant. The stick force and normal g are noted when the steady state has been reached, and the stick force per g obtained.

The main criticisms of this method are

(a) except at high speed it is difficult to hold a constant normal acceleration for an appreciable time, for the aircraft will tend to assume rapidly an extremely nose-up attitude with the speed falling off quickly, and the pilot is soon forced to release the normal acceleration by forward elevator movement,

(b) in general, by the time the steady g is reached the speed is beginning to fall off rapidly, and, if there is a large trim change with speed, this will appear as a direct error in the stick force per g measurements,

(c) if the attitude is becoming appreciably nose-up, the normal component of the weight is being reduced. Thus, if the steady normal g is being held by the pilot, it follows that the pitching velocity of the aircraft is being increased. The stick force to hold the steady g will, therefore, increase as the angle of climb increases, both due to the increasing pitching velocity and due to the angular acceleration of pitch. An analysis of this effect, following the lines of R. & M. 2027⁴ suggests that to obtain values of steady stick force per g within 5 per cent of the true value, the angle of climb should be less than 10 deg.

While this method is, therefore, quite useful at diving speeds the limitations at lower speed are such that its use is not recommended as a standard technique.

4.3. *Turning Flight Method.*—This method entails the measurement of the stick force change necessary to produce a given normal g , the g being obtained by putting the aircraft into a steady turn at the trimmed airspeed. The main advantage of this method is that the increased g state can be held for a considerable time without alteration of airspeed, until the pilot or auto-observer has satisfactorily recorded the necessary readings. This method is used extensively in America but also to a small extent in this country.

The main objections to this method are

(a) as discussed in section 3.3, the stick force per g measured by this method is not, in general, the least stick force per g that is measurable on the aircraft; and the stick force per g may vary considerably with the normal g used. Especially on large aircraft, it is only practical to use a maximum of 2 to $2\frac{1}{2}g$ during the tests, and the values of minimum stick force necessary to break the aircraft deduced from turning tests may grossly over-estimate those necessary during a vertical pull-out.

(b) at high values of the normal acceleration, it is difficult for the pilot to maintain a steady turn due to the sensitivity of the required normal acceleration to the angle of bank. Any sideslip arising from incorrect adjustment of the bank angle, will produce errors arising from (a) the pitching moment due to sideslip and (b) the contribution of the side force to the balance of forces, the latter being somewhat greater than it would be if the same sideslip angle were introduced during a straight pull-out.

It can be argued that the steady stick force per g can be obtained from measurements made in turning flight by evaluating the term representing the difference between them, namely:—

$$- m_e \frac{W}{S} S_\eta c_\eta \frac{B_2}{A_2} \frac{\bar{V}}{\bar{V}} \left[\frac{\bar{V} \bar{A}_1}{2\mu_1 \bar{n}} - \frac{l}{e} \frac{C_{L\gamma_s}}{2\mu_1} (i_c - i_a) \left(1 + \frac{1}{\bar{n}} \right) \right]$$

but this is really impractical due to the number of variables we need to know to evaluate this term, many of which can only be found sufficiently accurately by means of exhaustive flight tests.

Again, therefore, this method cannot be recommended for standard use, though checks can be made using this method to show if the stick force per g during the turn are unacceptably higher than the steady stick forces per g .

4.4. *The Suggested Standard Method.*—Because of the difficulties and objections recorded above, a method of test has been evolved at the R.A.E. which aims to

(a) set down a perfectly definite test procedure, which should enable a consistent answer to be produced for a given aircraft condition, and

(b) obtain a measure of the stick force per g which corresponds as closely as possible to the theoretical definition of the steady stick force per g in pure pitching motion. By so doing, in general, we obtain the value of the least stick force per g on the aircraft.

The flight procedure is as follows (*see Fig. 8*).

(1) *Low and Medium Speeds*

(a) Firstly the pilot holds the aircraft carefully, and approximately trimmed at the forward speed at which records are required, and when the normal acceleration is $1g$ and steady, both the g and the stick force are recorded.

(b) The speed is then decreased by easing the nose up gently without moving the trimmers or engine controls.

(c) When the speed has dropped sufficiently, the nose of the aircraft is pushed down rapidly to a definitely nose-down attitude, and then the pull-out is immediately commenced before too much speed is gained. The object is to get the aircraft moving with as constant a normal acceleration as possible *before the aircraft passes through a level fore-and-aft attitude, and with the speed steadily increasing until the trim speed is reached approximately as the aircraft reaches the fore-and-aft level.* The pilot should be asked to concentrate on keeping the normal acceleration constant not on keeping constant stick position or force.

(d) When the aircraft is approximately level fore and aft (say ± 5 deg) and the speed is approximately the same as the trimmed speed ($\pm 5 \rightarrow 10$ m.p.h.), a second record of normal acceleration and stick force is taken. This record should not be taken until the normal acceleration has become constant and it should remain constant for an appreciable time interval after recording has finished. The magnitude of this time interval or 'lag' time will depend on the aircraft inertia, etc., and can be determined from the records at forward C.G.'s by noting the time taken for appreciable response to occur after appreciable elevator control has been applied.

(e) Then in the usual manner

$$\text{stick force per } g = \frac{\text{change in stick force}}{\text{change in normal acceleration}}$$

Corrections may be applied to the trim condition by means of the trim curves, if available, to allow for the speed difference between trim and pull-out records.

(2) *High Speeds (diving when trimmed)*

The procedure is similar to (1) but instead of decreasing the speed before the pull-out it will be found necessary to increase the speed, for as the nose is pulled up to a level attitude the speed will be continually falling.

The method described above has been tried out at the R.A.E. on two aeroplanes, a Lancaster and a Mosquito. It was found that little practice on the part of the pilot was necessary before he was able to judge quite accurately the amount of speed increase or decrease required. For research purposes it is recommended that continuous records of normal acceleration, stick force, elevator angle and speed should be taken both at the trim and pull-out conditions, but for routine testing at establishments and aircraft firms it has been found sufficient to take single records during both the trim and the pull-out condition. Care must be exercised when relying on single records that the normal acceleration remains constant for an appreciable time after the record has been taken.

When analysing the continuous records of the pull-out to obtain the steady values of the stick force and elevator angles per g the following method was used:—

(i) The lag time between appreciable elevator movement and appreciable aircraft response was determined by examination of a considerable number of records. This was a fairly doubtful process because of the difficulty of determining from the experimental points the point at which appreciable movement occurred, due to the scatter and the presence of a certain amount of vibration, etc. It was, however, sufficient for our purpose to obtain a value well on the high side and, in fact, it is satisfactory to take a constant value, invariant with speed but covering the lowest speed condition. For example 1.0 sec was assumed for the Lancaster and 0.5 sec for the Mosquito.

(ii) Any records in which the normal acceleration was constant for less than the assumed lag time either at trim or pull-out were ignored.

(iii) The arithmetical mean values of the stick force, elevator angle and normal acceleration were obtained for the time that reasonably steady normal acceleration occurred, making allowance for the effect of lag. The following sketch illustrates this.

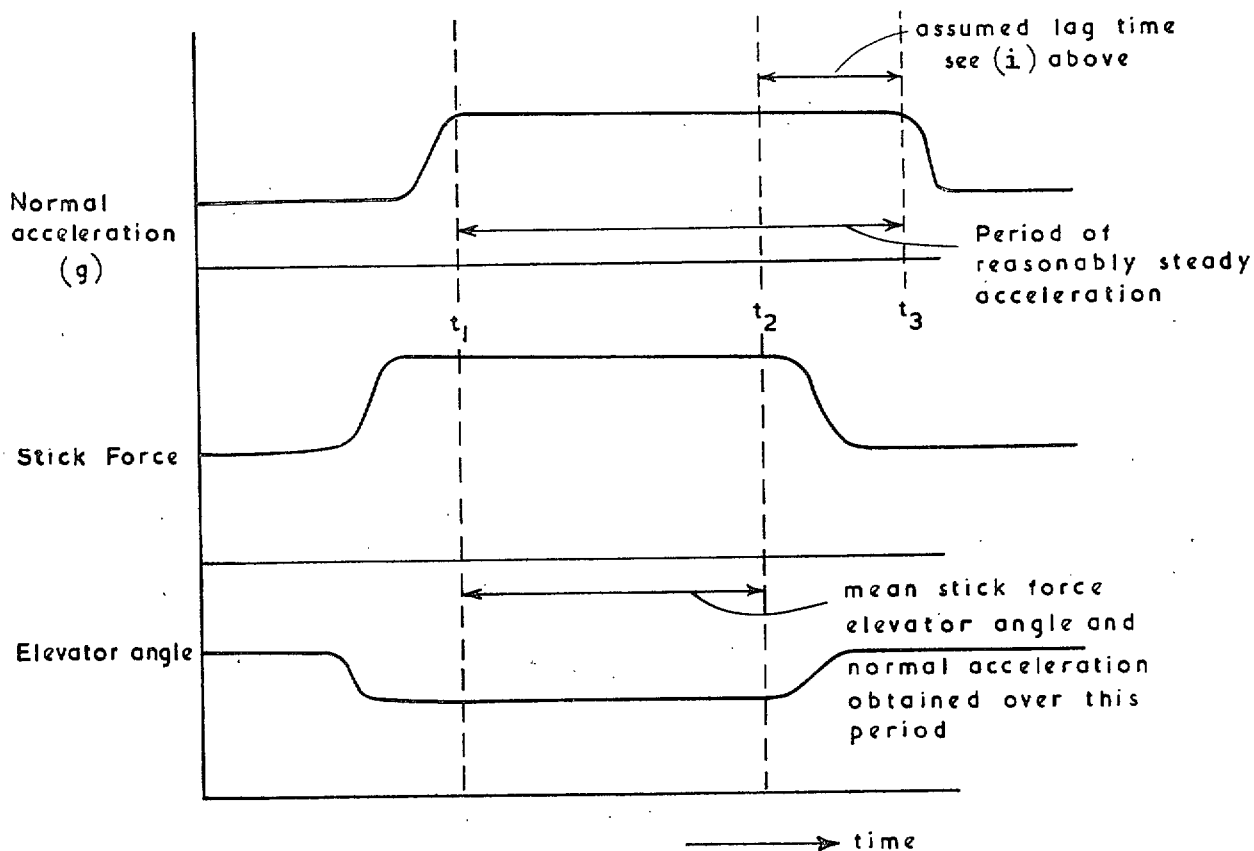

Thus, the normal acceleration is reasonably steady between t_1 and t_3 , but the mean values are only evaluated between times t_1 and t_2 , ($t_3 - t_2$ is the assumed lag time). As it is the acceleration which lags behind the control force and movements, it is not necessary to make an allowance for a lag at the beginning of the steady normal acceleration period.

It may be argued that this method is equivalent to the more simply expressed condition of obtaining constant stick force, normal acceleration and elevator angle, but in practice this is not so. For instance friction will mask the ideal shape of the stick force curves, the elevator angle movements may be so small at high speeds that it is not possible within the experimental

accuracy to say when the angle is steady, and alteration of the speed will cause the stick force and elevator angles to alter although they can be corrected to the first order by the trim curves as long as the normal acceleration remains constant.

Finally having obtained the values of stick force per g and elevator angle per g at 2 or more C.G. positions, the manoeuvre points can be obtained in the usual manner by plotting stick force and elevator angle per g and finding by interpolation or extrapolation the C.G. position at which stick force and elevator angle per g go to zero.

It is clear, therefore, that by using this method of measurement we obtain values of the stick force per g pertaining very closely to the theoretical definition. The actual conditions obtained in ideal circumstances using this method are:—

- (a) The same airspeed in both the initial ($1g$) state and the final increased normal acceleration state, though in the latter case the airspeed will generally be changing.
- (b) The rate of change of the gravity field, and thus the pitching acceleration can be zero.
- (c) The normal acceleration will be steady, so that the only necessary difference from the theoretical definition is the probable presence of a longitudinal acceleration in the increased g state; this would not be expected to affect the manoeuvrability characteristics materially.

5. *Flight Measurements Using the Suggested R.A.E. Method.*—5.1. *Lancaster.*—5.1.1. *Range of tests.*—The aeroplane used for the tests was a Lancaster III fitted with Merlin 28's. The tail-plane and elevator were normal except that the surface stiffness of the elevator had been increased by the insertion of two extra ribs between each of the existing ribs. This is a standard retrospective modification made to all Lancaster fabric covered elevators.

A considerable number of pull-outs were made at three C.G. positions, *viz.*, $0.239\bar{c}$, $0.292\bar{c}$ and $0.354\bar{c}$ and over a speed range from 150 to 360 m.p.h. Three C.G. positions were used to demonstrate, if possible, the linearity of the stick force and elevator angle per g with C.G. position. With the C.G. at $0.354\bar{c}$ (*i.e.*, 64.7 in. behind the datum), the aircraft is loaded well beyond the present aft limit of 60.6 in. behind the datum. This position was taken to obtain some measurements of the manoeuvring characteristics near to the manoeuvre points.

The stick forces were measured at the pilot's wheel and this may include friction (± 3 to 4 lb); the elevator angles were measured at the elevator near a hinge position and thus do not include circuit stretch. The accuracy of the stick force recorder is $\pm \frac{1}{2}$ lb and the elevator angle ± 0.1 deg.

Continuous records were taken both during trim and pull-out conditions by means of a ciné record of an automatic observer panel. The auto observer included:

- (a) Stick force indicator.
- (b) Elevator angle indicator.
- (c) Airspeed indicator.
- (d) Altimeter.
- (e) Pioneer visual accelerometer mounted normal to the body axis and approximately at the C.G. position.

Corrections to the values of stick force and elevator angle to allow for the usually negligible speed errors were obtained from some previously measured trim curves on the same aeroplane. To obtain the steady stick force per g , the continuous records were analysed by the method described in section 4.4.

General arrangements of the aeroplane and horizontal tail surfaces are given in Figs. 9, 10.

5.1.2. Results of tests

(a) *Time histories of the pull-outs.*—A few specimen records of pull-outs using the R.A.E. method are given in Figs. 13 to 16, Fig. 13 for the forward C.G. of $0.239\bar{c}$ (47.0 in.), Fig. 14 for the intermediate C.G. of $0.292\bar{c}$ (55.4 in.) and Figs. 15 to 16 for the aft C.G. of $0.354\bar{c}$ (64.7 in.). In each of these records the values of normal acceleration, stick force, elevator angle A.S.I. and the flight path angle to the horizontal are plotted against a time scale. The values of γ (flight path angle) have been deduced from altimeter and A.S.I. readings and are not very accurate; they will, however, provide a sufficiently accurate indication of the aeroplane attitude for our purpose.

There is nothing striking about the time history curves given in Figs. 13, 14, the only noteworthy features are the steadiness with which the pilot has held the normal acceleration and the small changes in A.S.I. over most of the pull-out record. It is clear, however, that the assumed lag time for the Lancaster of 1.0 sec (*see* section 4.4) covers well any lag between pilots action and the response of the aircraft in pitch.

With the extreme aft C.G. (*see* Figs. 15, 16) there are some interesting features. Here, as described in section 3.2 the C.G. is so near the manoeuvre point at very low speeds, that the stick forces needed to initiate the recovery and hold the angular acceleration which the pilots considered reasonably gentle, are much greater than the force necessary to hold the final steady normal acceleration. The records $C_2 \rightarrow C_4$ are good examples of this, C_3 being a very gentle initiation and C_2 and C_4 more rapid ones. The record C_1 shows a typical record obtained by a pilot on being instructed to do a gentle normal pull-out at 200 m.p.h. A.S.I., demonstrating well the time which elapses between the peak of the stick force and the peak on the normal acceleration curves, with no period at all in which steady conditions were obtained before the pilot had to ease the stick forward.

(b) *Stick force and elevator angle per g.*—The values of stick force and elevator angle per g for the Lancaster obtained from analysis of a considerable number of such records as those given in Figs. 13 to 16 are plotted in Figs. 17, 18 against speed and C_L for the three C.G. positions. The scatter of the points is reasonably good, taking into account the size of the aircraft and accuracy of instruments (including friction).

The points worth noting in regard to these curves are the appreciable rise in the stick force per g with speed, despite the increase of the surface stiffness of the elevator as compared with the more normal Lancasters at that time, the tendency of the elevator angle per g curves to flatten out at low C_L values instead of approaching the origin, and the drop off in stick force per g at low speeds. The first two phenomena can be explained by distortion of the tail surfaces such that A_2 tends to zero³, although a certain amount may still be due to a rise in B_2 with speed. The reason for the third phenomenon is obscure, for the alteration in H_n' previously measured will not account for $H_m' \rightarrow$ zero.

(c) *Manoeuvre points.*—The curves of stick force per g and elevator angle against C.G. position are given in Fig. 19 for four forward speeds. It will be seen that over the speed range 200 to 350 m.p.h. A.S.I., the curves are linear and the two groups intersect approximately on the abscissa, indicating that over this speed range the manoeuvre points are in a constant position and that within experimental accuracy the stick force per g and elevator angle per g are linearly dependent on the manoeuvre margin as indicated by theory. The mean position of the manoeuvre point stick free from 200 to 350 m.p.h. is at $0.407\bar{c}$ and stick fixed at $0.404\bar{c}$, at 150 m.p.h. there is evidence (*see* Fig. 17 (a)) that the manoeuvre point moves forward to $0.354\bar{c}$ though it would need completion of the curves at more forward C.G.'s to 150 m.p.h. A.S.I. to confirm this.

(d) *Peak stick forces per g.*—In Fig. 20, the values of the peak stick force per g (*i.e.*, peak stick force/peak normal g) have been plotted for the whole series of pull-outs made to establish

the value of the steady stick forces per g , and comparisons made with the mean curves of the steady stick force per g from Fig. 17(a). Here it is clearly shown that, following the arguments of section 3.2,

(a) when the steady stick force per g is high and the value of H_m' is high, the peak stick force per g agrees closely with the value of the steady stick force per g ,

(b) when the steady stick force per g is low and the value of H_m' is low, the peak stick force per g is very much in excess of the steady stick force per g ; up to approximately 25 lb per g has been measured.

5.2. *Mosquito*

5.2.1. *Range of tests.*—The aircraft used for these tests (Mosquito DZ 294) is a fighter Mk. II with normal fighter external shape. The elevator was the modified metal covered elevator and the tailsetting was -0.4 deg. No external petrol tanks were carried. General arrangements of the aircraft and horizontal tail surfaces are given in Figs. 11, 12.

The aircraft carried a similar instrumentation to that used for the Lancaster tests except that a more sensitive stick force indicator was used (accuracy $\pm \frac{1}{4}$ lb). A considerable number of pull-outs were made at two C.G. positions; *viz.*, $0.280\bar{c}$ and $0.335c$ over a speed range of 150 \rightarrow 450 m.p.h. A.S.I. at approximately 7,000 ft. A similar method of analysis of the continuous records to that used for the Lancaster was used here again.

5.2.2. *Results of tests.*

(a) *Time histories of pull-outs.*—Again a few specimen records of pull-outs are given in Figs. 21, 22, Fig. 21 for the forward C.G. of $0.280\bar{c}$ and Fig. 22 for the aft C.G. of $0.335\bar{c}$. There is nothing particularly worth noting about the records taken at the forward C.G., except that it is clear that the assumed lag times for the Mosquito of 0.5 sec (*see* section 4.4) amply covers the lags at all speeds. Once more, however, at aft C.G. it is apparent that much more force is needed on the control column to initiate the recovery than to hold the steady value of g later attained, the extent of the peaking of the stick force being dependent on the rate of growth of g . It is also worth noting that at the aft C.G. over most of the speed range a positive change of elevator angle was needed to hold the steady normal acceleration, indicating that at this C.G., the C.G. is behind the manoeuvre point stick fixed.

(b) *Stick force per g and elevator angle per g .*—Values of the stick force and elevator angle per g were deduced from the time history curves using the method as outlined in section 4.4. These values are plotted in Figs. 23, 24, against speed and C_L . The scatter of the points is small even when the mean stick force per g is as low as 2 to 3 lb. It is interesting to note the steady rise in stick force per g at high speeds despite the fact that the elevators are metal covered. This point is discussed very fully in R. & M. 2371⁸ which describes the measurement of aero-elastic distortion on the Mosquito aircraft.

(c) *Manoeuvre points.*—The values of the stick force and elevator angle per g are cross-plotted against C.G. positions in Figs. 25 (a) and (b) for a number of forward speeds, and the deduced values of the manoeuvre points stick fixed and free are given in Figs. 26 (a) and (b) plotted against the C_L value. It will be seen that at the aft C.G. at which measurements were taken (*i.e.*, $0.335\bar{c}$), there was a negative manoeuvre margin stick fixed over the majority of the speed range and only a small positive manoeuvre margin stick free of $0.01\bar{c}$ up to 250 m.p.h. We have thus been able to demonstrate in this case that by the R.A.E. method it is possible to obtain consistent manoeuvre measurements when the C.G. is behind a manoeuvre point.

(d) *Peak stick forces per g .*—In Fig. 27 the peak stick forces per g obtained during the pull-outs have been plotted in comparison with the measured steady stick forces per g , as for the Lancaster in Fig. 20. Again the same features can be seen, the steady stick force per g being up to about 8 lb per g less than the peak stick force per g mean curve.

6. *Conclusions.*—(i) It has been demonstrated that, for the majority of practical cases the theoretical definition of steady stick force per g in a vertical circle will indicate the lowest stick force for which a given normal acceleration can be reached in a number of assumed dynamic or turning conditions. In a few cases, it is possible to show that either in a turn or sharp pull-up the value of the peak stick force per g is lower than the steady stick force per g , but

(a) the difference between the two cases is very small and usually within experimental error of measurement,

and (b) the aerodynamic conditions are prohibitive on other grounds, *i.e.*, either too much stability gained or lost on freeing the stick.

(ii) A method of measurement which gives a value of the stick force per g very close to the theoretical definition has been suggested and demonstrated on two aircraft. The test procedure is definite and fairly straightforward, and consistent answers should be obtained using it. It is possible to use the method from the highest speeds down to very low climbing speeds, still with safety, and measurements behind the manoeuvre points are possible.

(iii) Therefore, as the various methods of measurement of stick force per g at present in use may readily give vastly different values of the stick force per g , it is suggested that the steady stick force per g should be regarded as the measurement required, and that the method of measurement suggested and demonstrated should be used as the standard method.

(iv) As the forces in an unsteady manoeuvre may be very much higher than those indicated by the steady stick force per g , consideration should be given to the necessity of providing an extra criterion to prevent too severe a divergence between the steady stick force per g and the peak stick force per g obtained during specific manoeuvres. A considerable amount of attention will need to be directed, however, to the pilots opinion of such divergences, and it is expected that considerable accurate testing will be necessary to obtain measurements sufficient to determine such a criterion numerically.

LIST OF SYMBOLS

\bar{A}_1	$= A_1 - A_2 B_1/B_2$
A_2	$= \partial C_{L_T} / \partial \eta_0$
B_1	$= \partial C_H / \partial \alpha_T$
B_2	$= C_H / \partial \eta_0$
\bar{c}	mean chord of wing = S/b
c_n	mean chord of elevator
C_H	elevator hinge moment / $\frac{1}{2} \rho V^2 S_n c_n$
C_L	lift of complete aircraft / $\frac{1}{2} \rho V^2 S$
g	acceleration due to gravity
h	distance of C.G. from leading edge of mean chord / \bar{c}
h_m	value of h for zero elevator travel per g
h_m'	„ „ „ „ „ stick force „
H_m	$= h_m - h$
H_m'	$= h_m' - h$

LIST OF SYMBOLS—*contd.*

$i_a ml^2$	moment of inertia of aircraft about x axis
$i_b ml^2$	" " " " " " " y "
$i_c ml^2$	" " " " " " " z "
m_e	gear ratio between stick and elevator (radians per ft)
$\bar{n}g$	total normal acceleration
ng	additional normal acceleration (relative to straight glide)
q	angular velocity about y axis
Q	stick force per g
S	wing area
S_η	elevator area
\bar{V}	tail volume = $S_T l/S \bar{c}$
$\bar{\bar{V}} = \bar{V}/(1 + F)$	
W	= all-up weight of aircraft
γ_s	angle of inclination of flight path to the horizontal in a spiral (positive on climb)
η_0	angle between elevator and tailplane chords
$\mu_1 = W/\rho g S l$	

For further definitions see R.A.E. Report No. Aero 1912.

REFERENCES

No.	Author	<i>Title, etc.</i>
1	—	Ministry of Aircraft Production—Design Requirements for Aeroplanes. Air Publication 970.
2	—	Stability and control Flight Test Methods—Army Air Forces—Air Technical Service Command Wright Field, Dayton, Ohio. A.A.F. Technical Report No. 5242.
3	—	Specification for Stability and Control Characteristics of Airplanes. Navy Dept. Report No. SR.119A (April, 1945).
4	Gates and Lyon	A Continuation of Longitudinal Stability and Control Analysis. Part I, General Theory. R. & M. 2027. February, 1944.
5	Gates	Proposal for an Elevator Manoeuvrability Criterion. A.R.C. 5981, June, 1942. (To be published).
6	Jones and Greenberg	Effect of Hinge-moment Parameters on Elevator Stick Forces in Rapid Manoeuvres. N.A.C.A. ARR. No. L4J12 (SR1 No. 853). November, 1944.
7	Phillips	An Investigation of Additional Requirements for Satisfactory Elevator Control Characteristics. N.A.C.A. Technical Note No. 1060, June, 1946.
8	Bisgood and Lyons	Interim Report on the Flight Measurement of Aero-elastic Distortion in Relation to its Effects on the Control and Longitudinal Stability of a Mosquito Aircraft. R. & M. 2371. March, 1946.

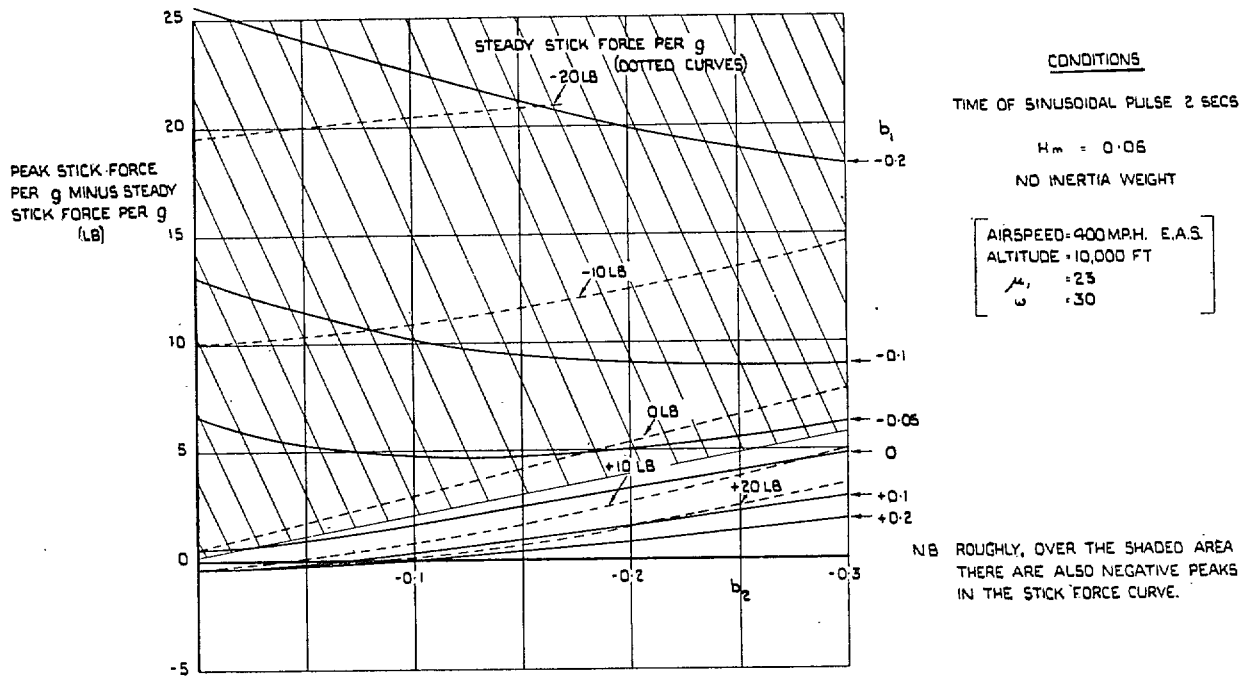

Fig. 1. Variation of the difference between the peak stick force per g measured during a sinusoidal pulse of elevator angle and the steady stick force per g for the aeroplane of Ref. 6.

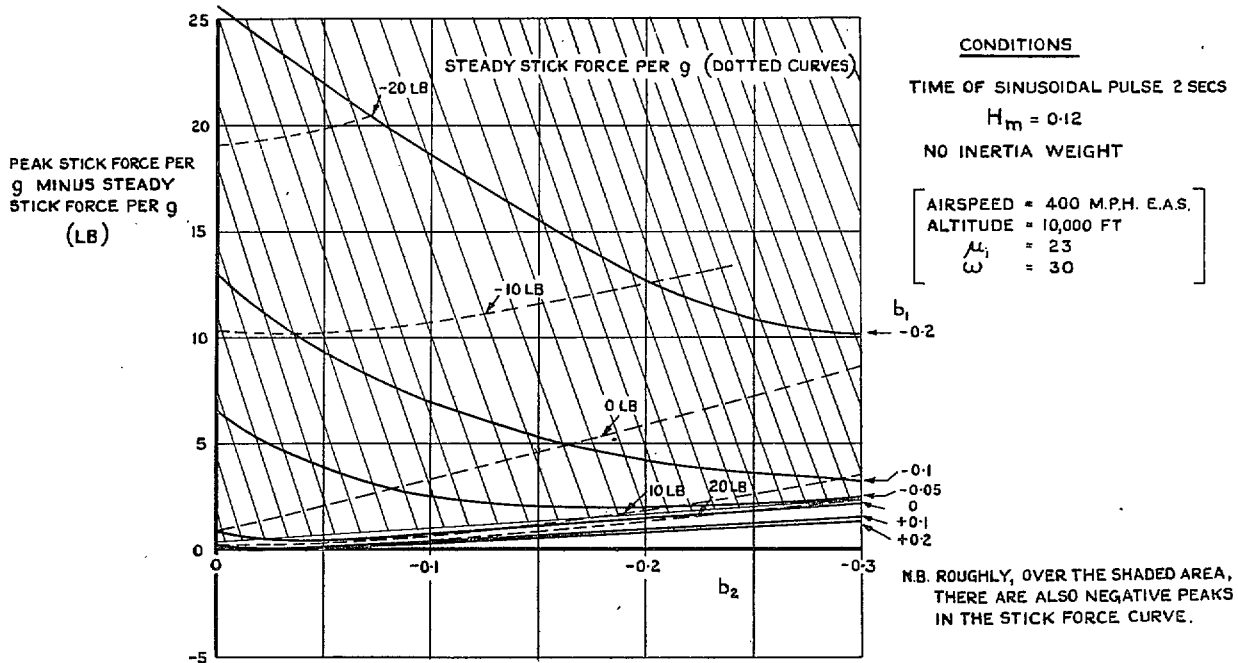

Fig. 2. Variation of the difference between the peak stick force per g measured during a sinusoidal pulse of elevator angle and the steady stick force per g for the aeroplane of Ref. 6.

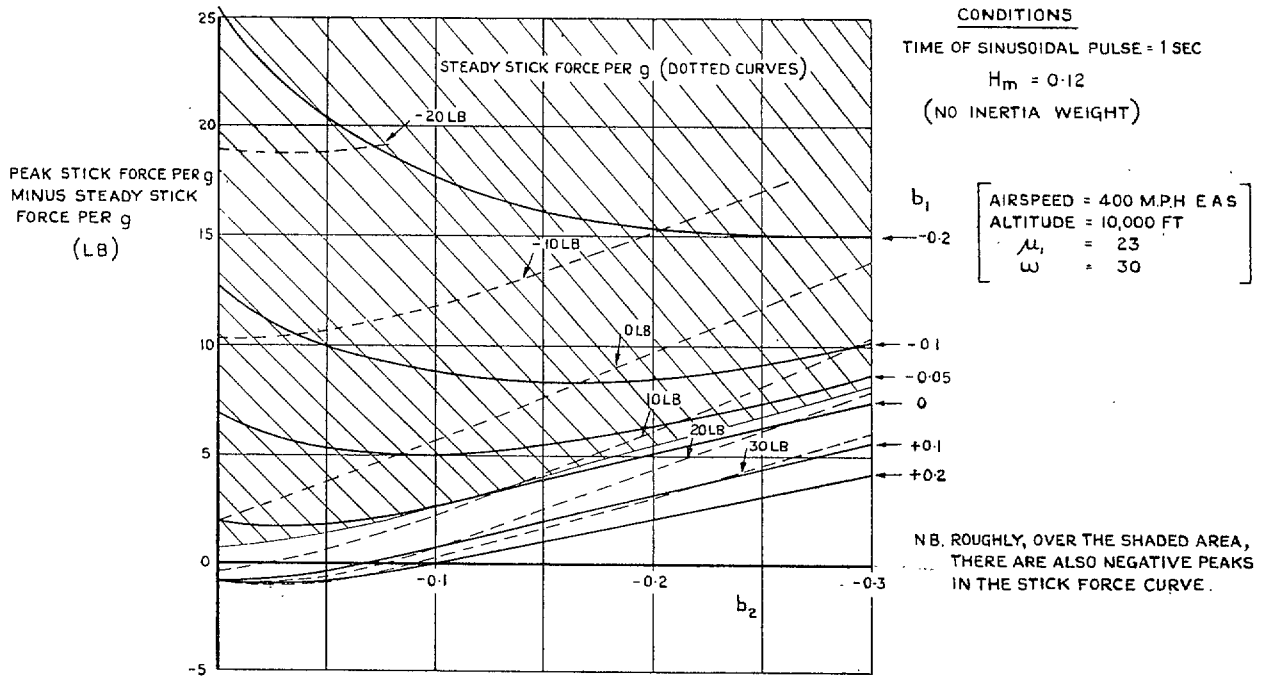

Fig. 3. Variation of the difference between the peak stick force per g measured during a sinusoidal pulse of elevator angle and the steady stick force per g for the aeroplane of Ref. 6.

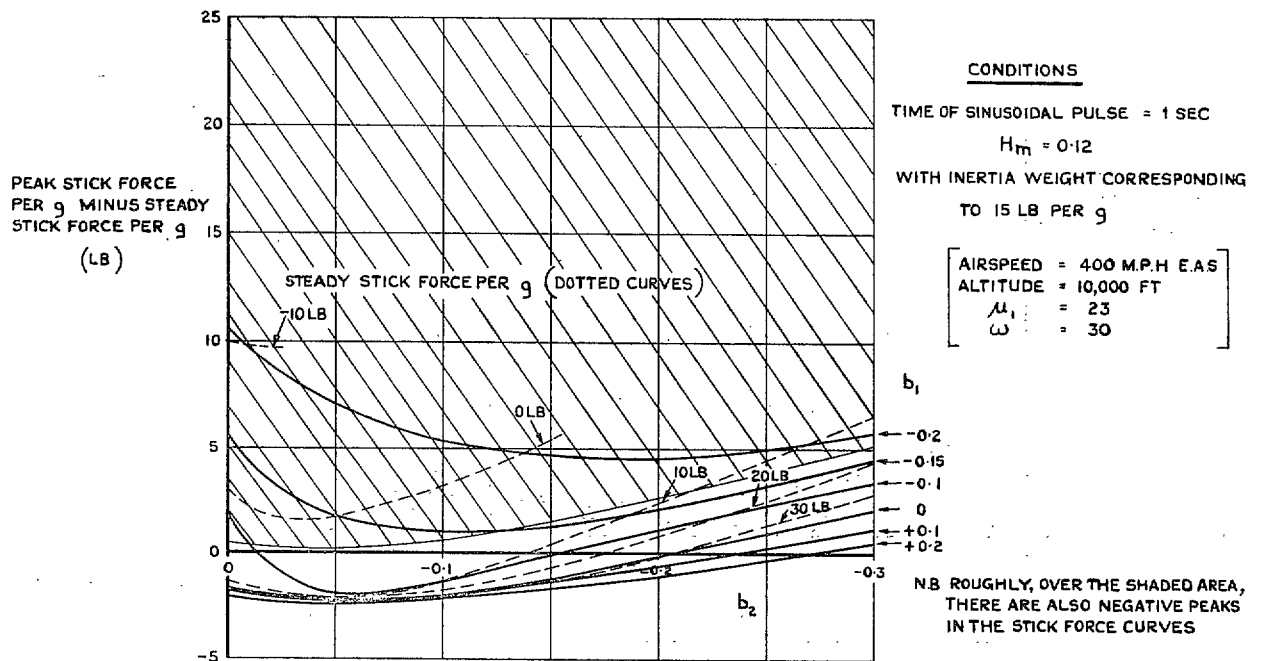

Fig. 4. Variation of the difference between the peak stick force per g measured during a sinusoidal pulse of elevator angle and the steady stick force per g for the aeroplane of Ref. 6.

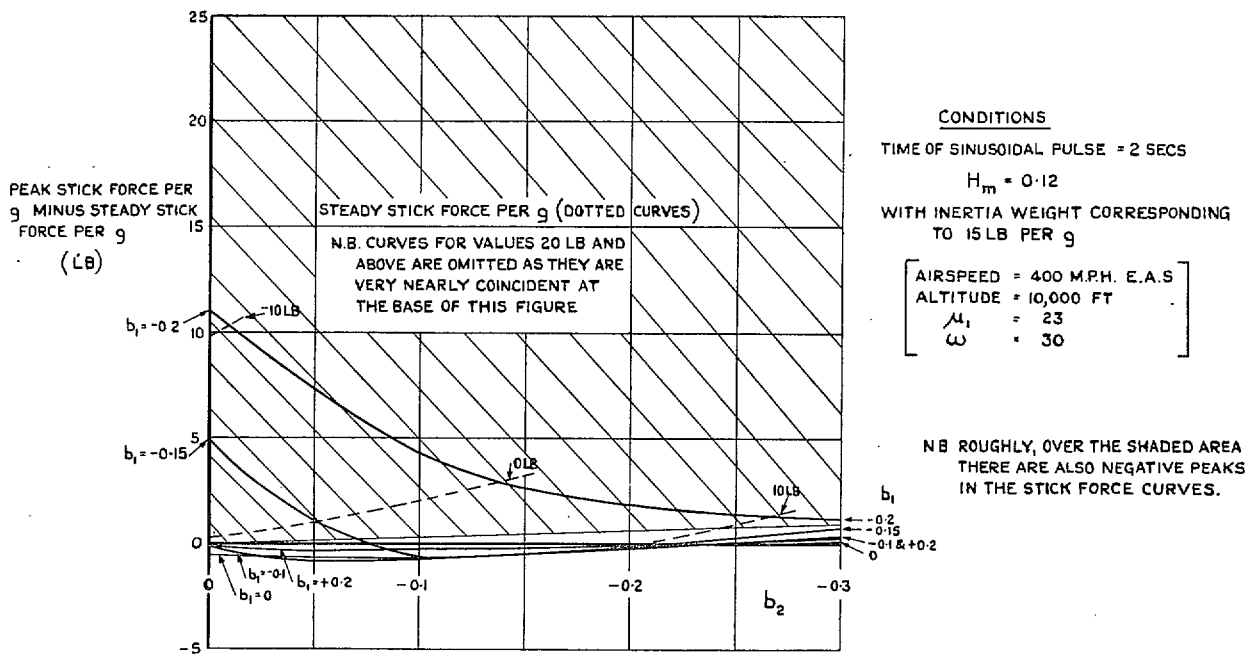

Fig. 5. Variation of the difference between the peak stick force per g measured during a sinusoidal pulse of elevator angle and the steady stick force per g for the aeroplane of Ref. 6.

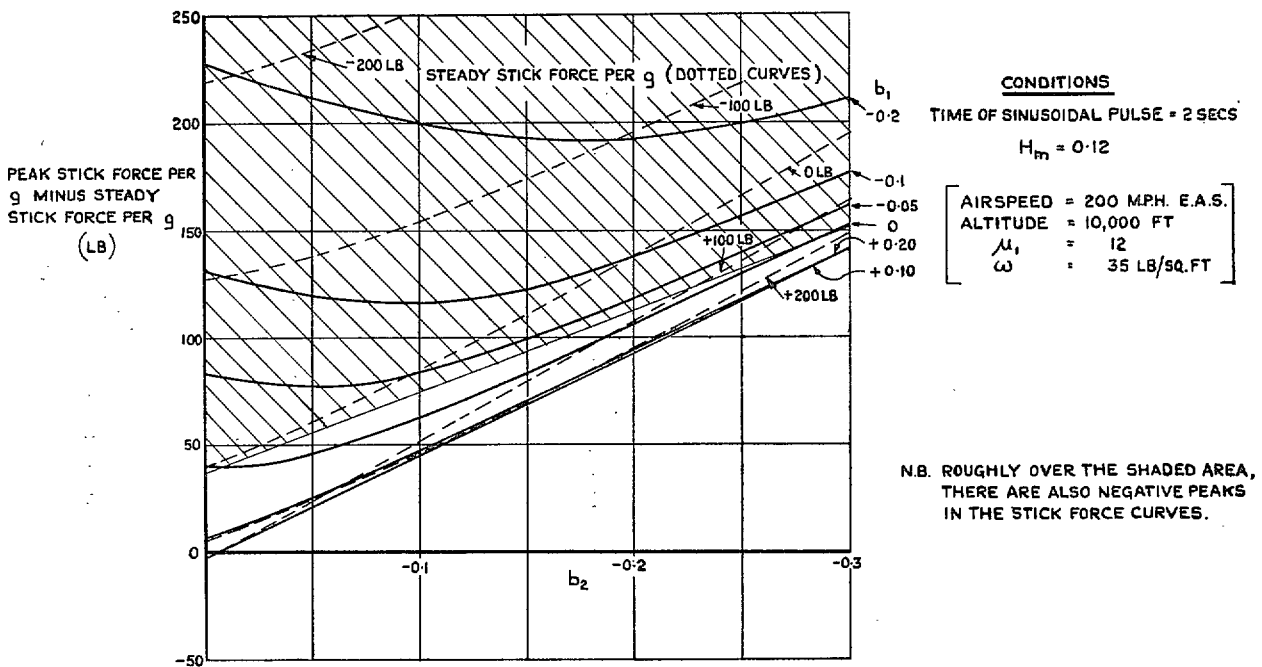

Fig. 6. Variation of the difference between the peak stick force per g measured during a sinusoidal pulse of elevator angle and the steady stick force per g for a heavy A/C ($\mu_1 = 12$).

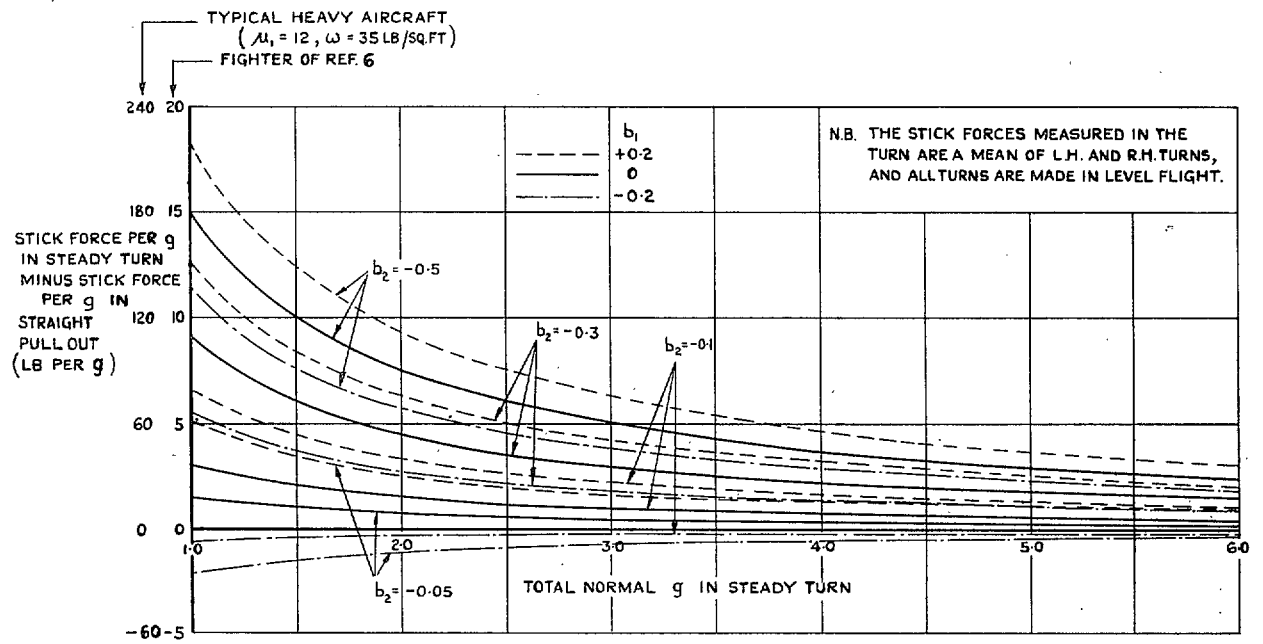

Fig. 7. Variation of the difference between the stick forces per g as measured in the steady turn and the straight pull-out with the normal acceleration in the steady turn.

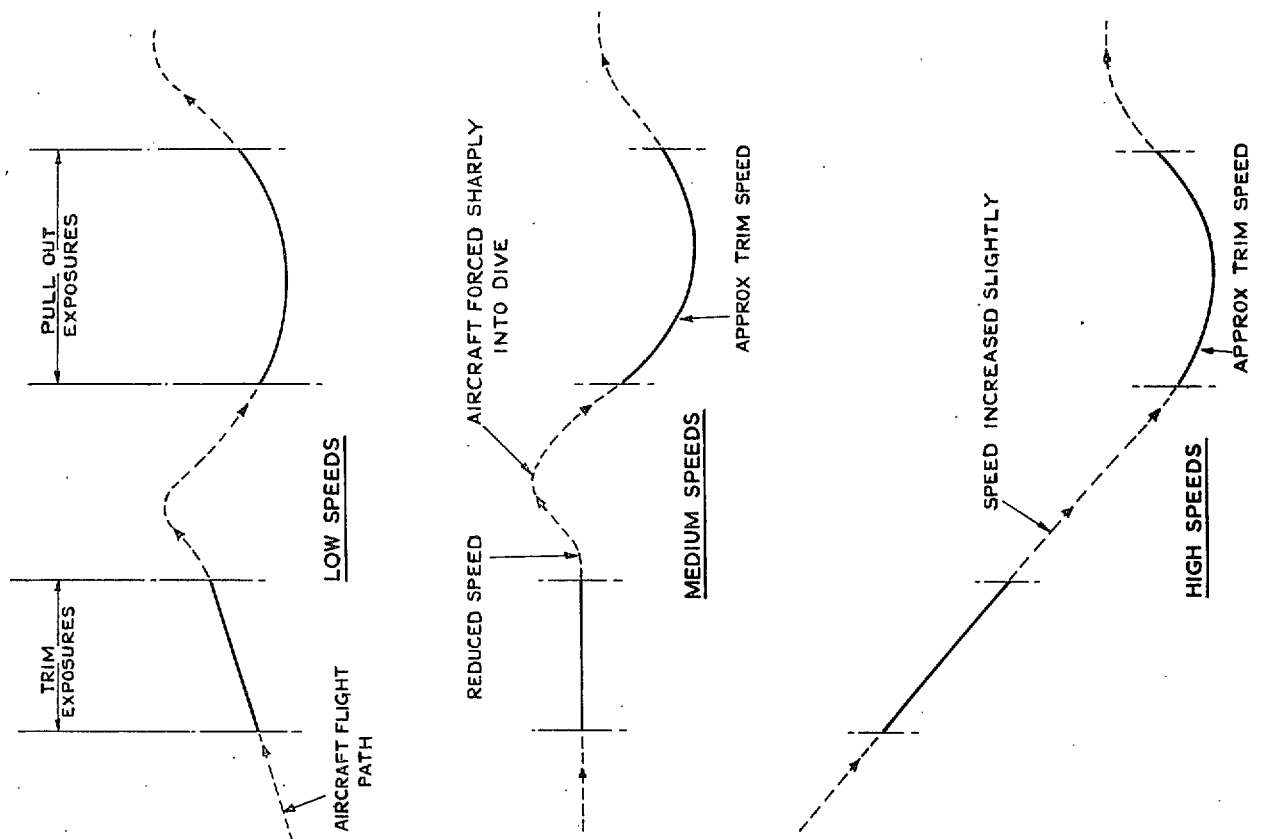
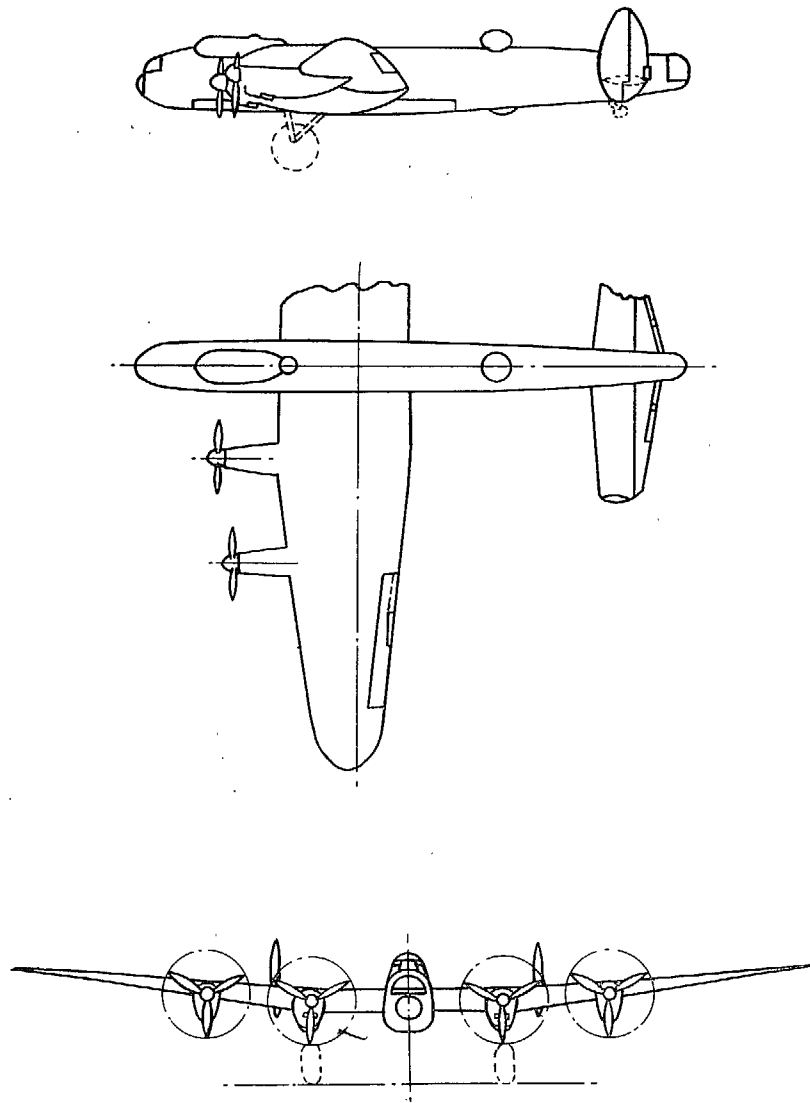

Fig. 8. Sketch illustrating pull-out technique.



0 50
SCALE :- FT

Fig. 9. General arrangement of Lancaster III ND 743.

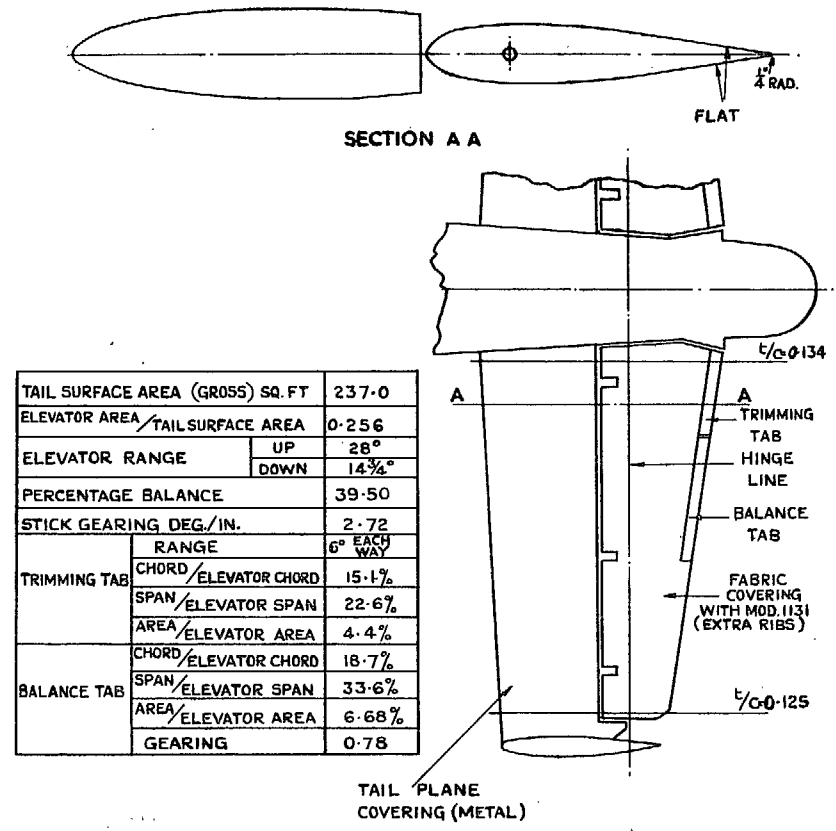

Fig. 10. Sketch of Lancaster tailplane.

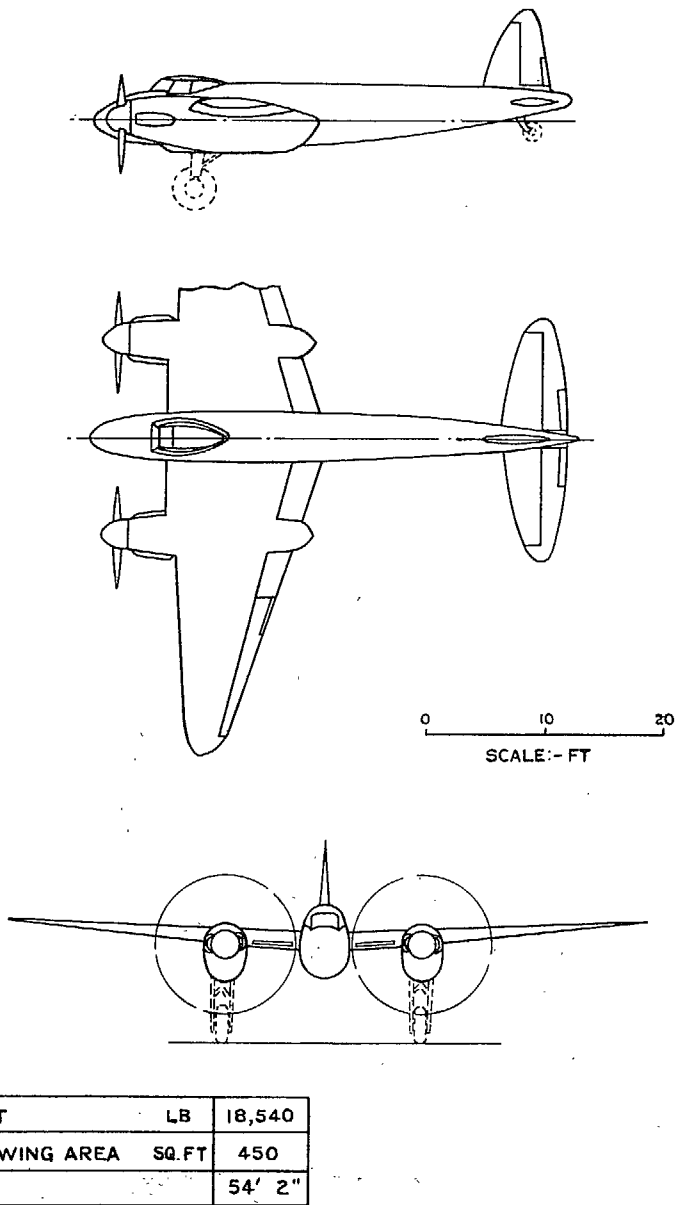

Fig. 11. General arrangement of Mosquito F Mk. II DZ 294.

TAIL SURFACE AREA (GROSS) SQ.FT	87.4
ELEVATOR AREA (LESS HORN)	TAIL SURFACE AREA 0.358
ELEVATOR ANGLES	UP 21.5°
	DOWN 12.5°
PERCENTAGE HORN BALANCE	6.9
STICK GEARING DEG/IN. (ELEVATOR NEUTRAL)	2.1
TAB GEARING	0.3
TAB TRIMMING ANGLES	± 7.5°
TAB CHORD / ELEVATOR CHORD	25.5%
TAB SPAN / ELEVATOR SPAN	38.3%
TAB AREA / ELEVATOR AREA	9.78%

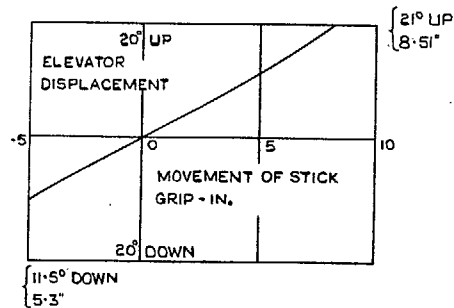
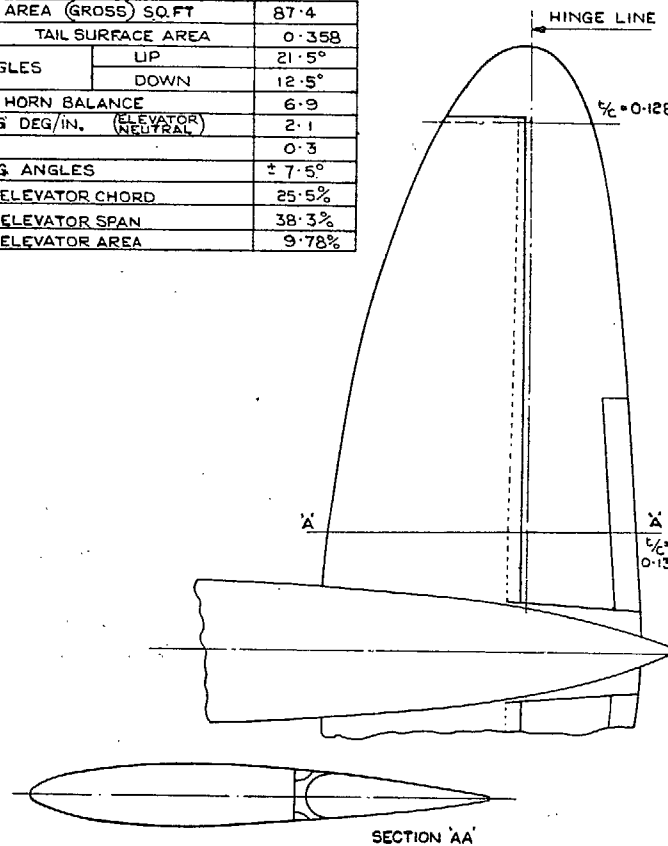

Fig. 12. Sketch of Mosquito tailplane.

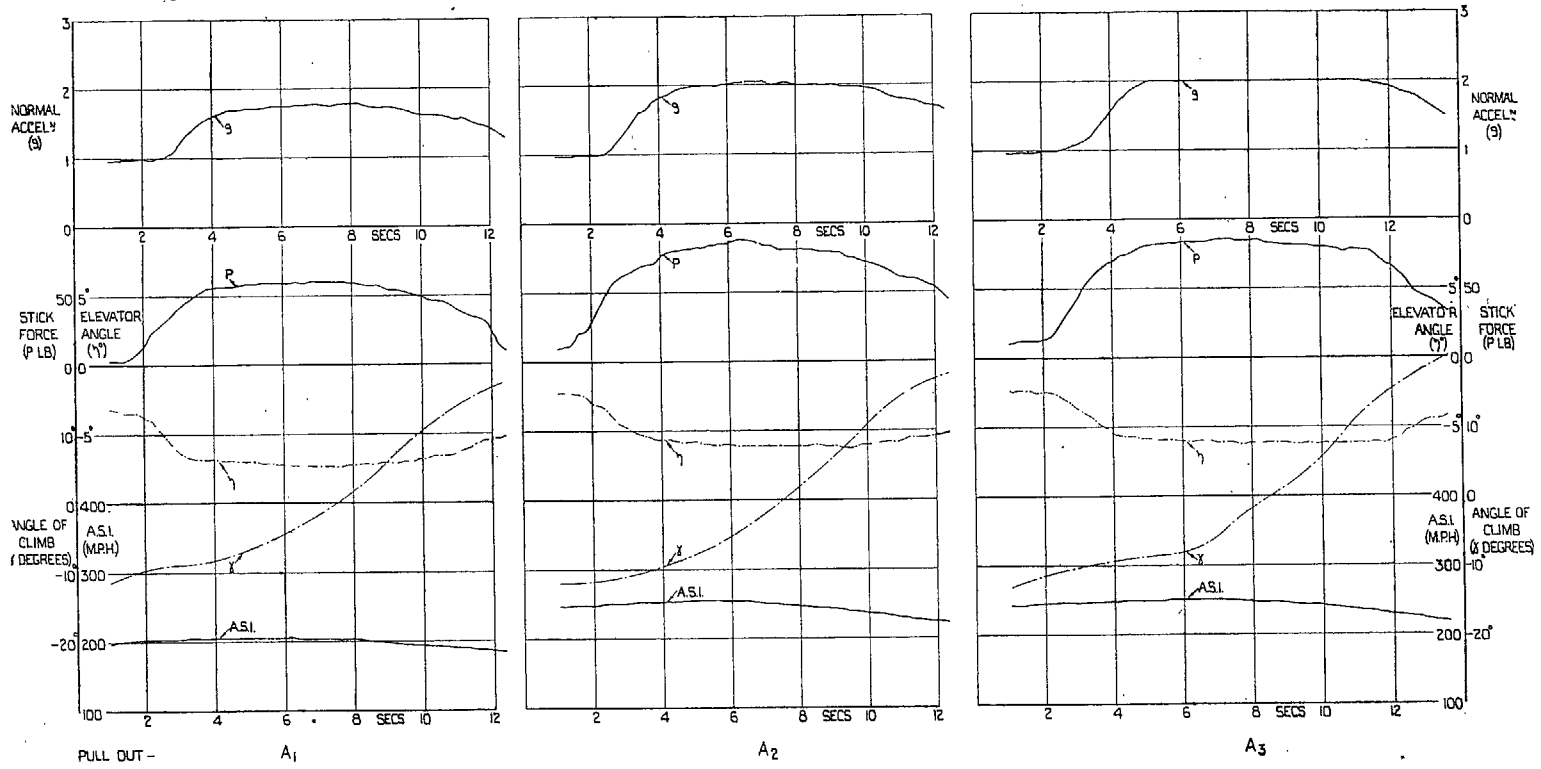

Fig. 13. Typical records of pull-outs with C.G. forward at 47 in. (0.239ε).
Lancaster ND 743.

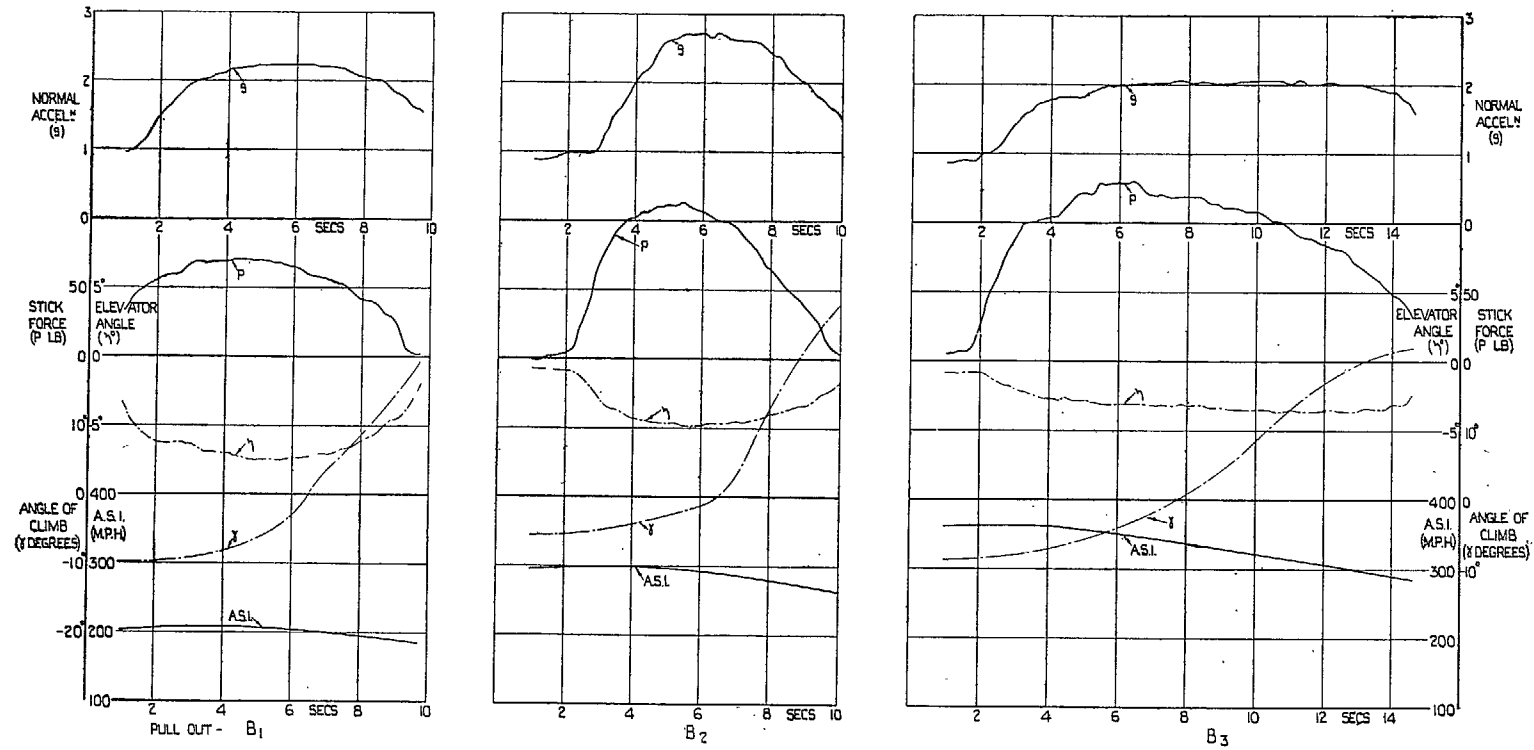

Fig. 14. Typical records of pull-outs with intermediate C.G. at 55.4 in. (0.292c).
Lancaster ND 743.

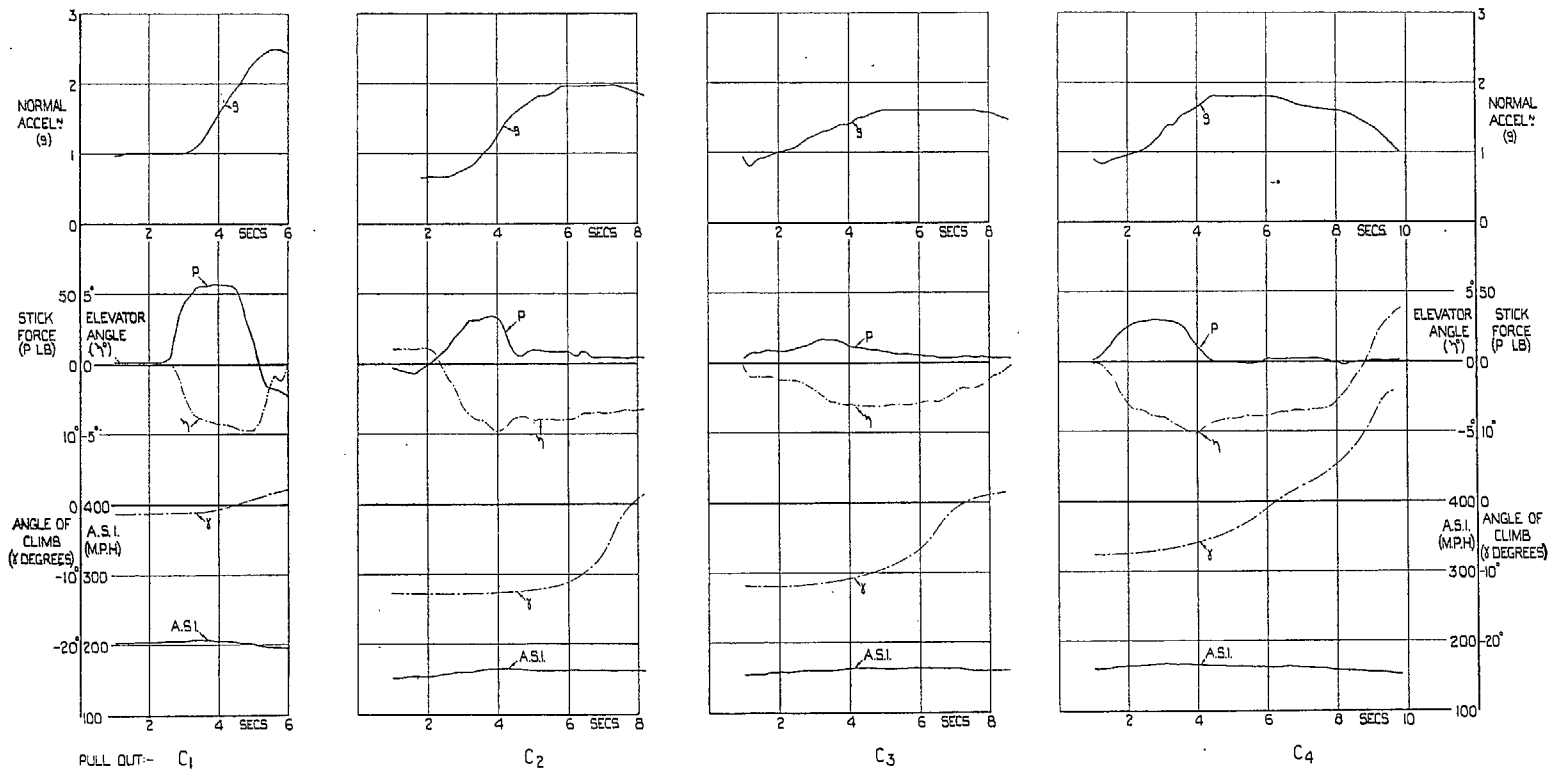

Fig. 15. Typical records of pull-outs with C.G. aft at 64.7 in. (0.3455). Lancaster ND 743.

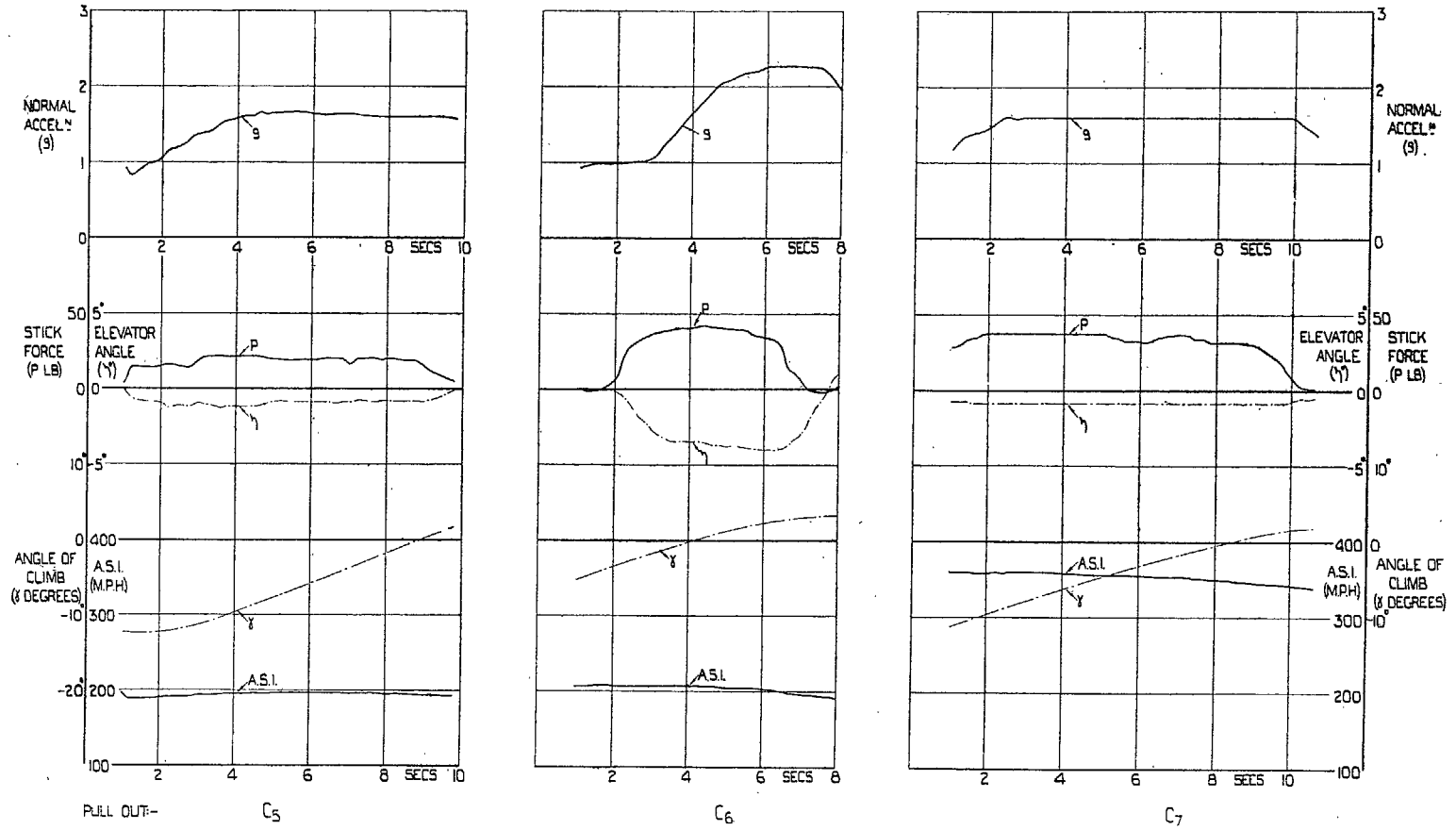

Fig. 16. Typical records of pull-outs with C.G. aft at 64.7 in. (0.354c̄).
Lancaster ND 743.

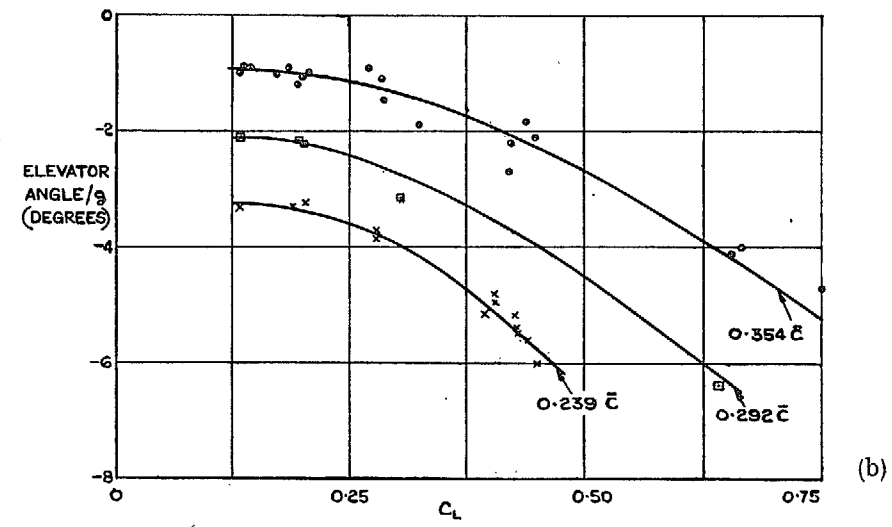
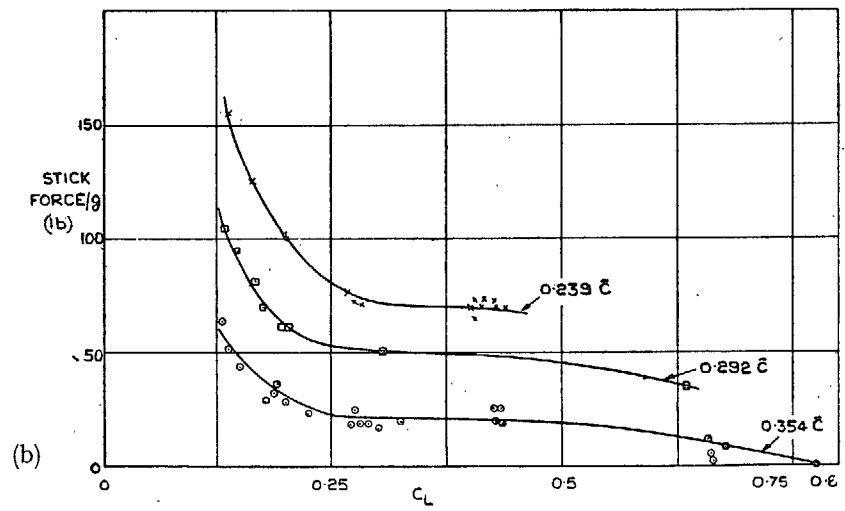
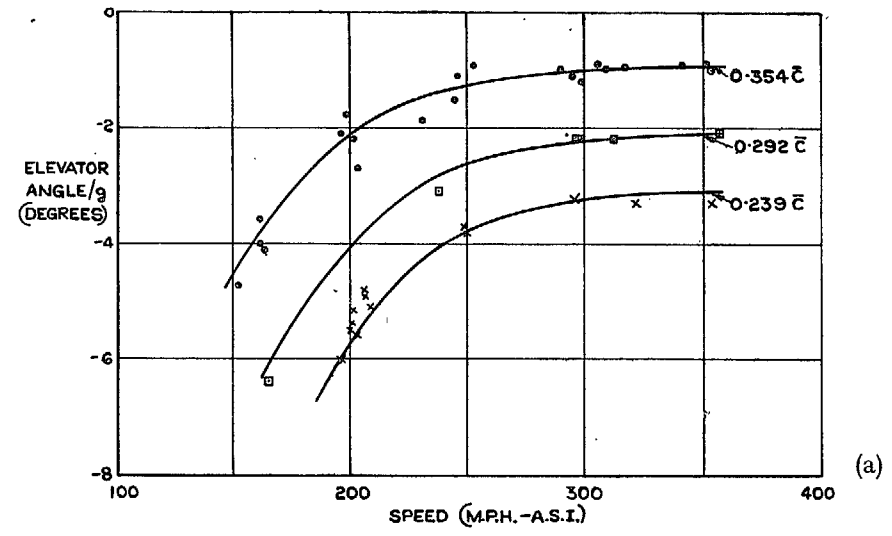
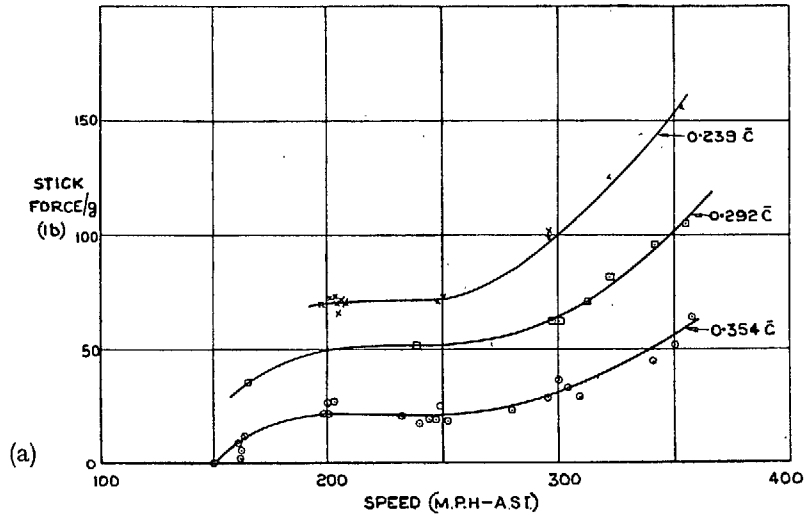

Fig. 17 (a) and (b). Steady values of stick force/g against speed and C_L for three C.G. positions. Lancaster ND 743.

Fig. 18 (a) and (b). Steady values of elevator angle/g against speed and C_L for three C.G. positions. Lancaster ND 743.

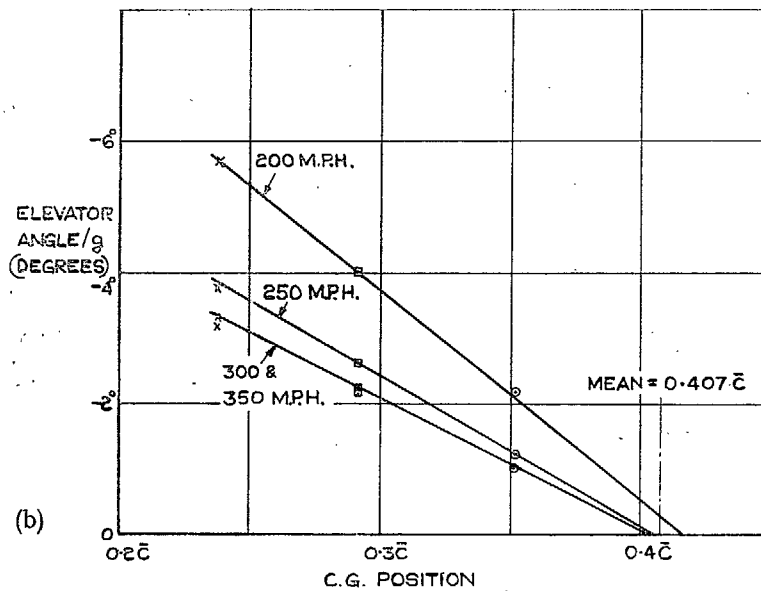
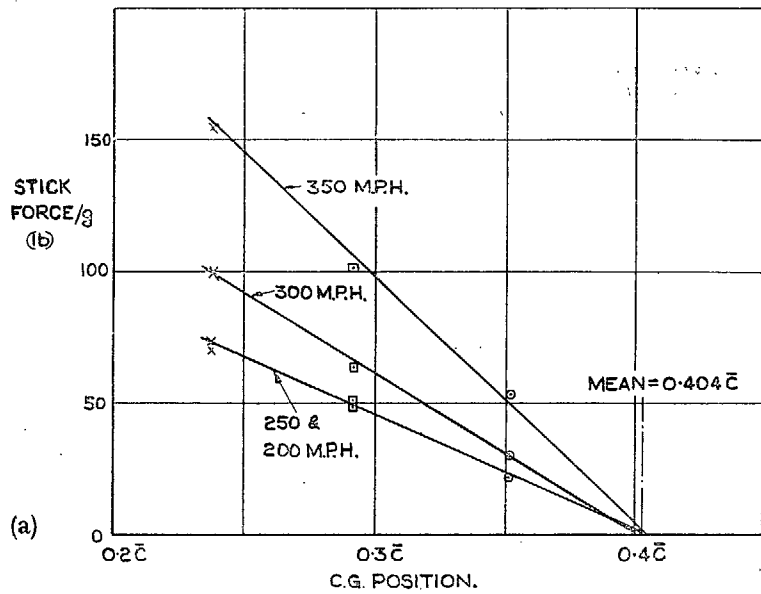

Fig. 19 (a) and (b). Steady values of stick force/g and elevator angle/g against C.G. position for four varying speeds. Lancaster ND 743.

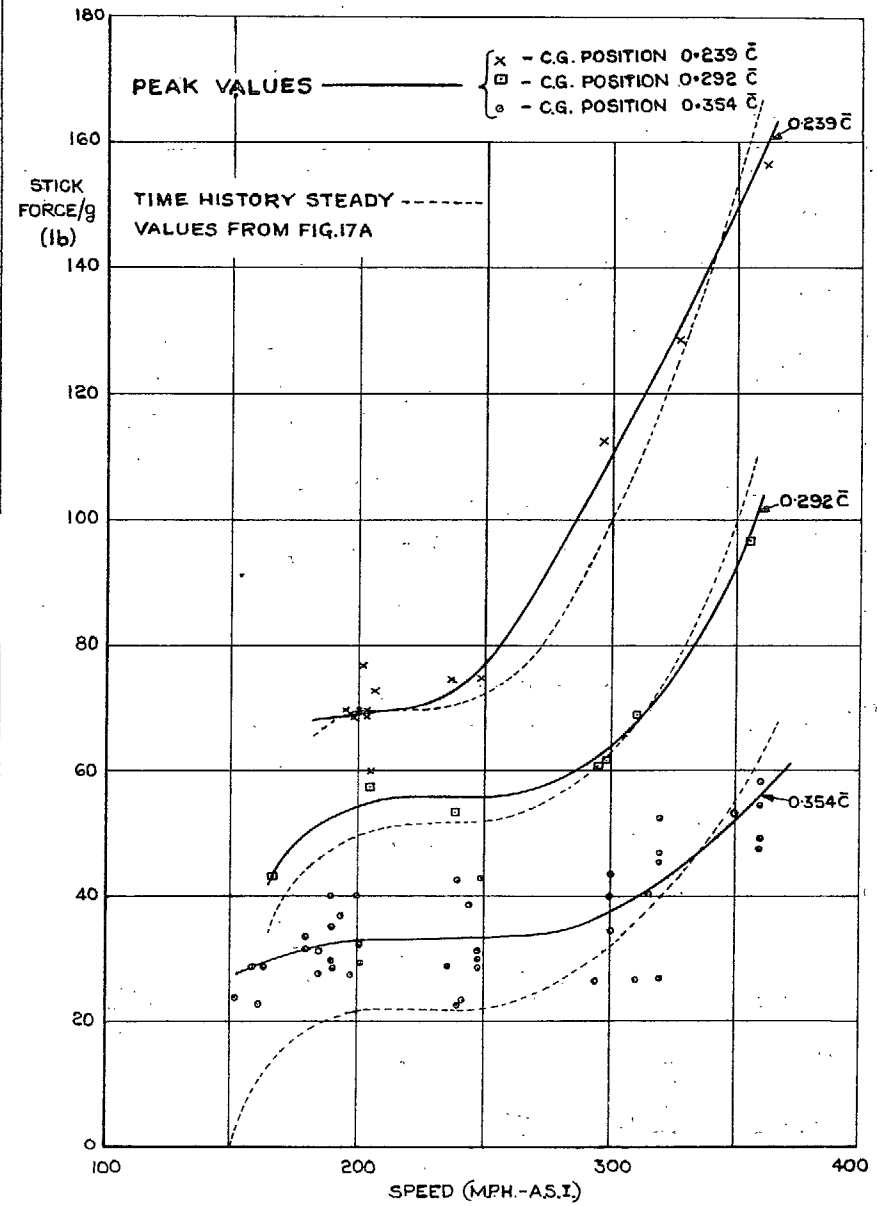

Fig. 20. A comparison of the steady and peak values of stick force/g against speed for three C.G. positions. Lancaster ND 743.

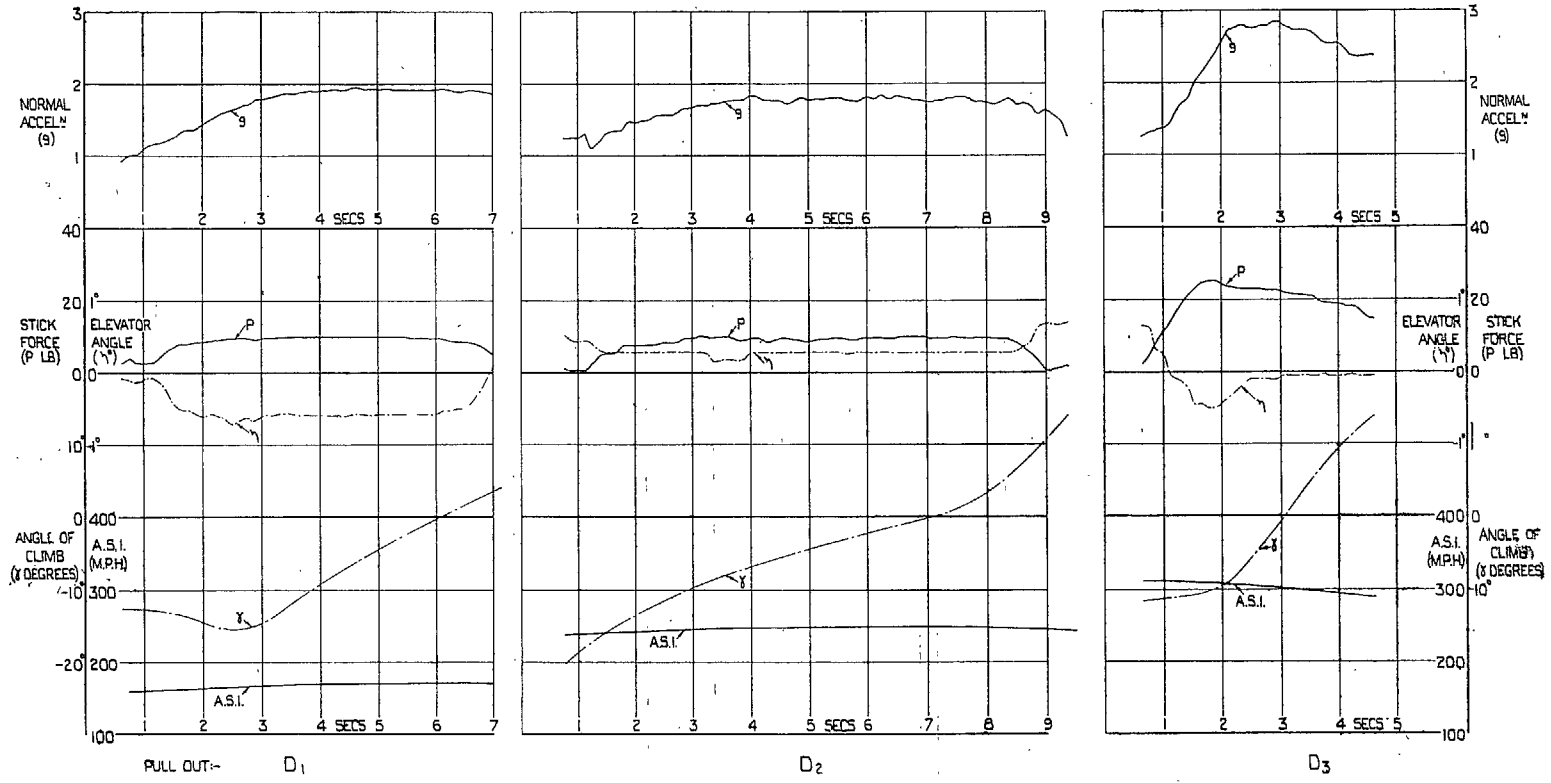

Fig. 21. Typical records of pull-outs with C.G. forward at 0.280 \bar{c} .
Mosquito DZ 294.

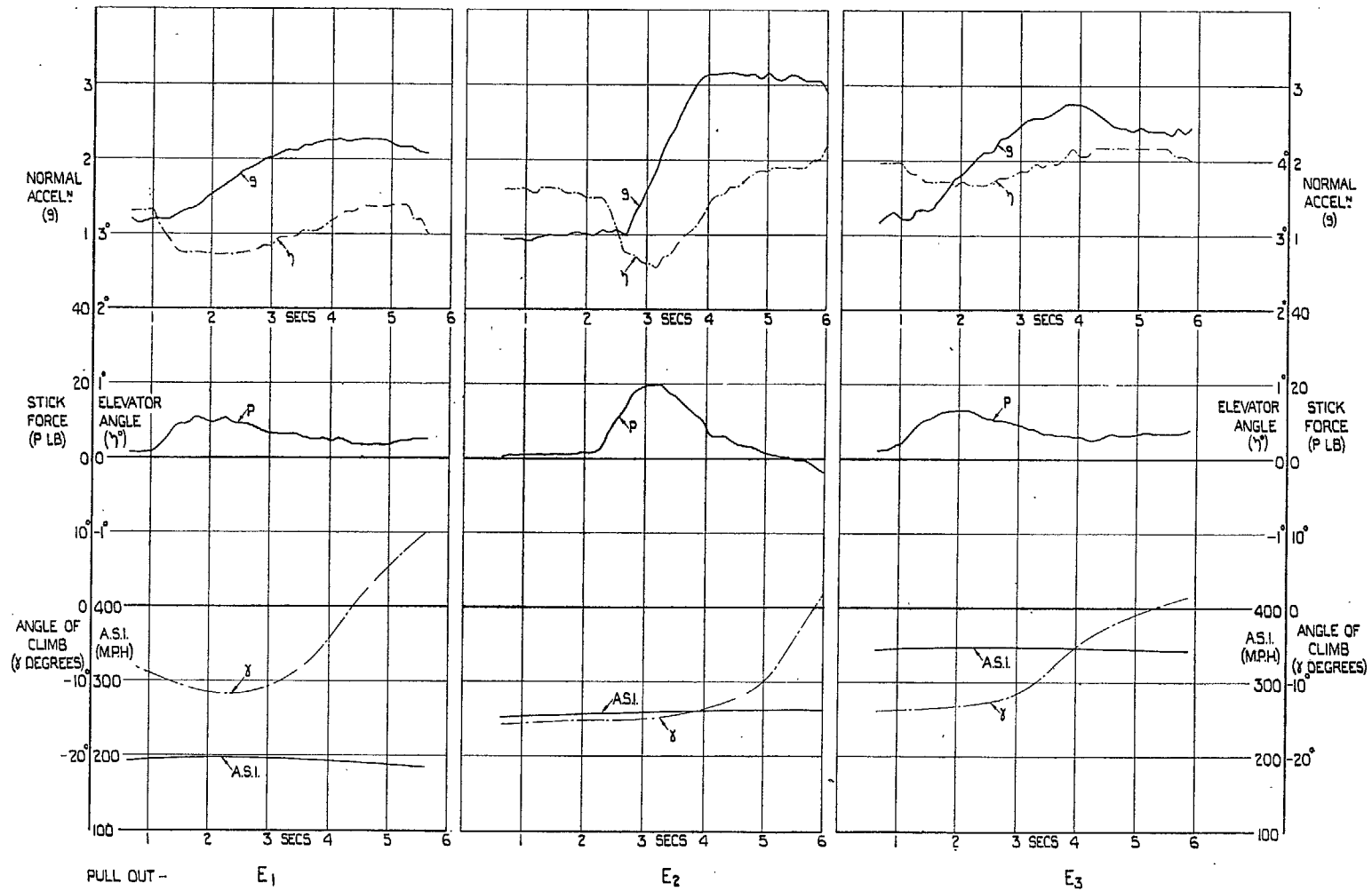
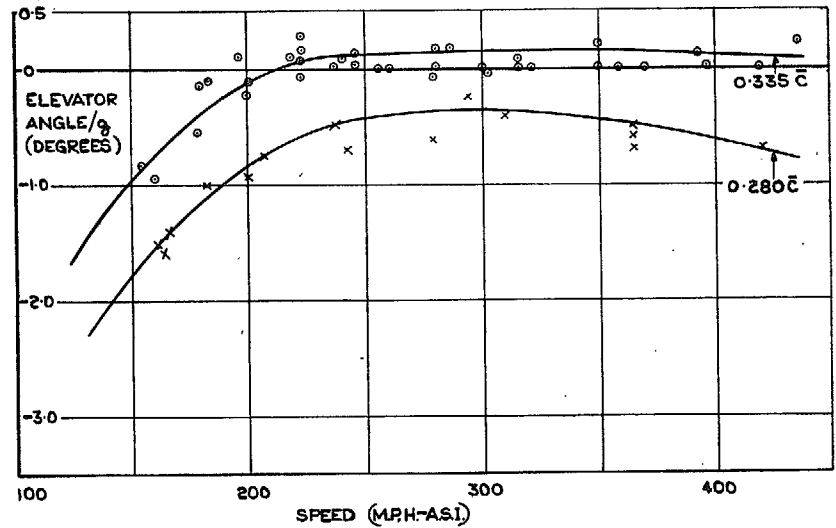
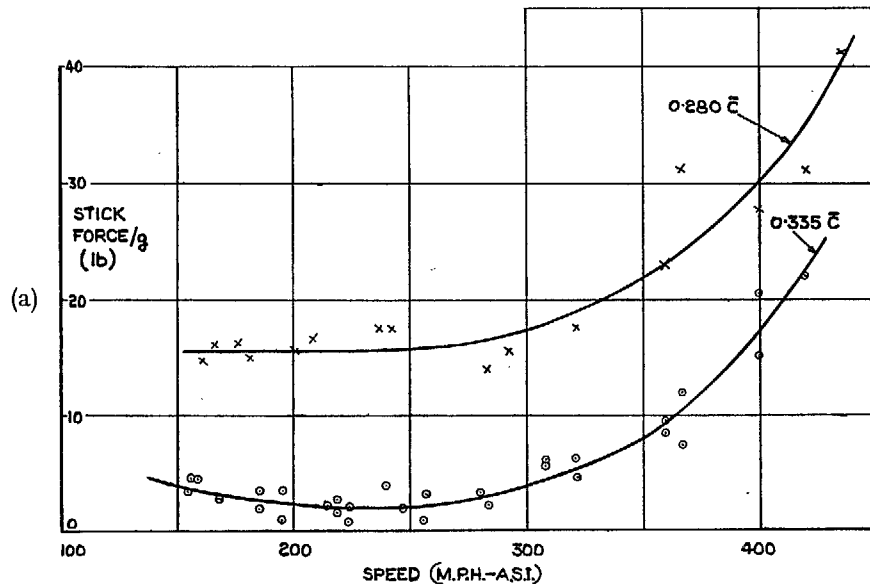

Fig. 22. Typical records of pull-outs with C.G. aft at 0.335c.
Mosquito DZ 294.



31

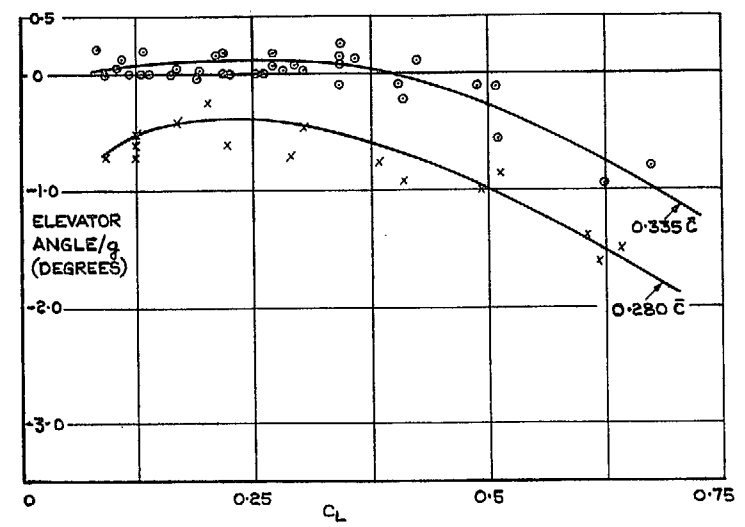
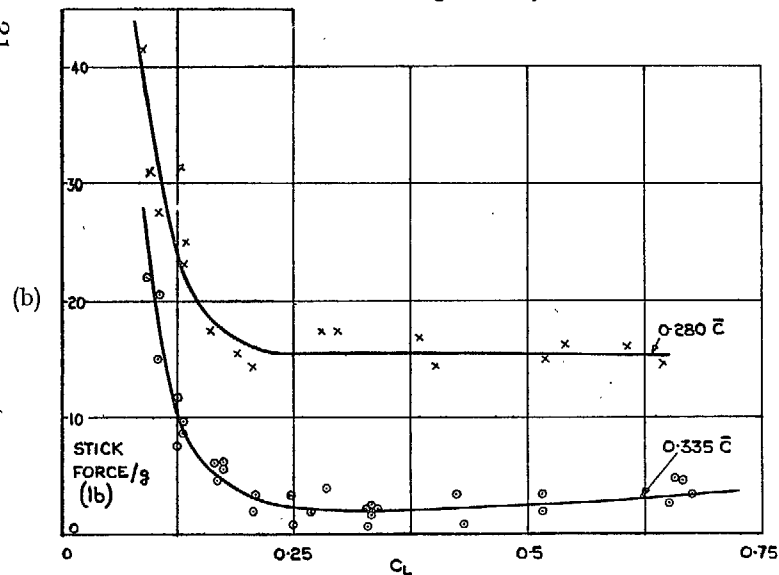

Fig. 23 (a) and (b). Steady values of stick force/g against speed and C_L for two C.G. positions. Mosquito DZ 294.

Fig. 24 (a) and (b). Steady values of elevator angle/g against speed and C_L for two C.G. positions. Mosquito DZ 294.

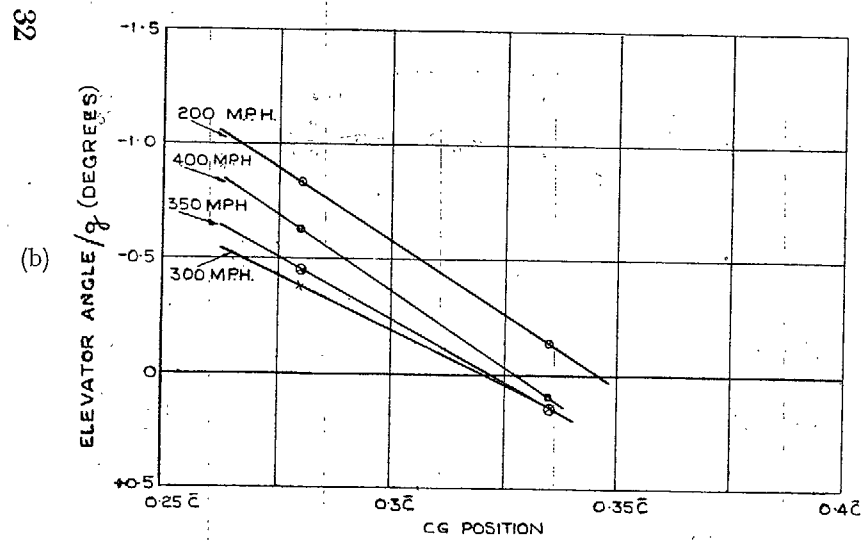
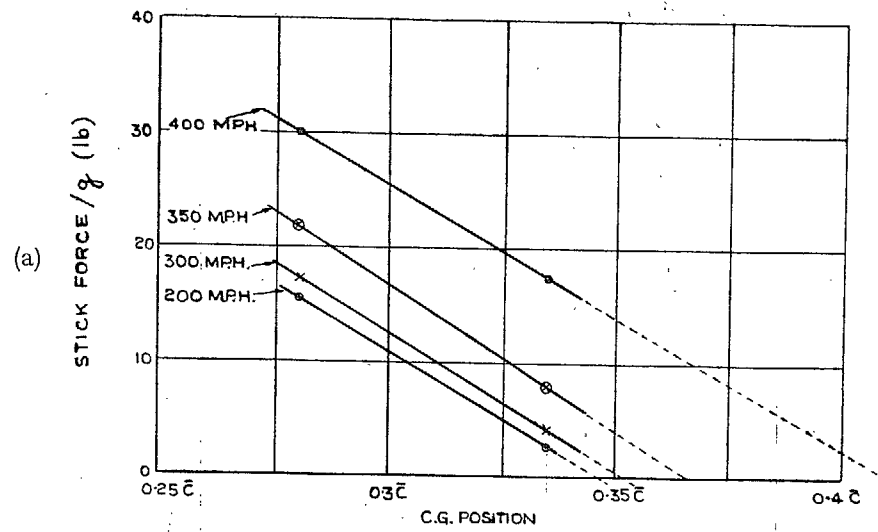

Fig. 25 (a) and (b). Steady values of stick force/ g and elevator angle/ g against C.G. position for four varying speeds. Mosquito DZ 294.

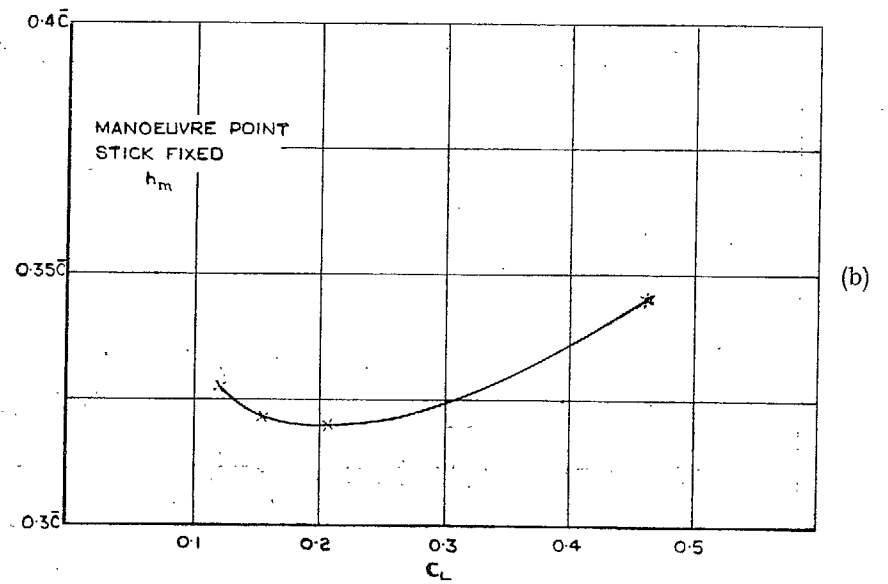
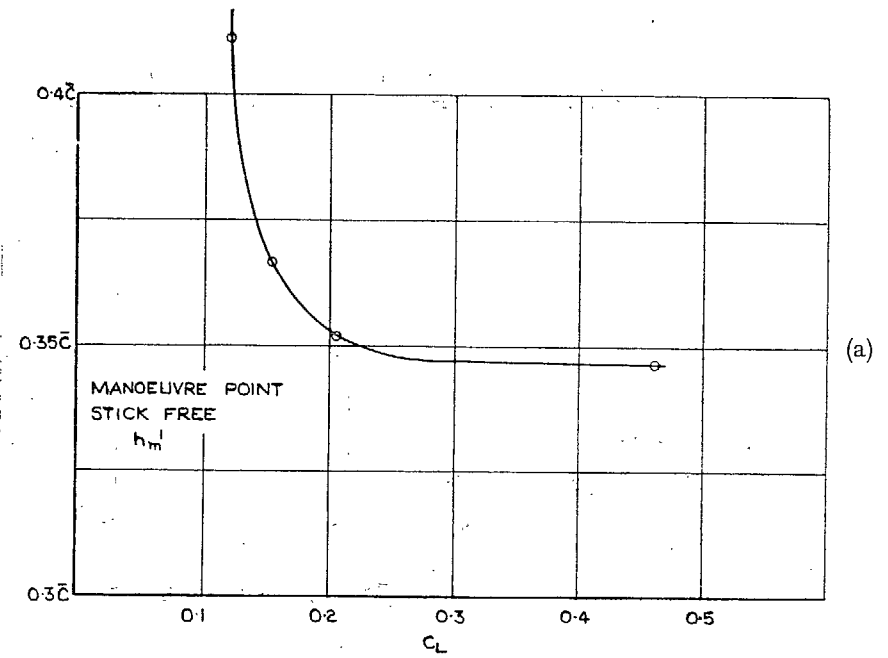

Fig. 26 (a) and (b). Values of manoeuvre points against C_L . Mosquito DZ 294.

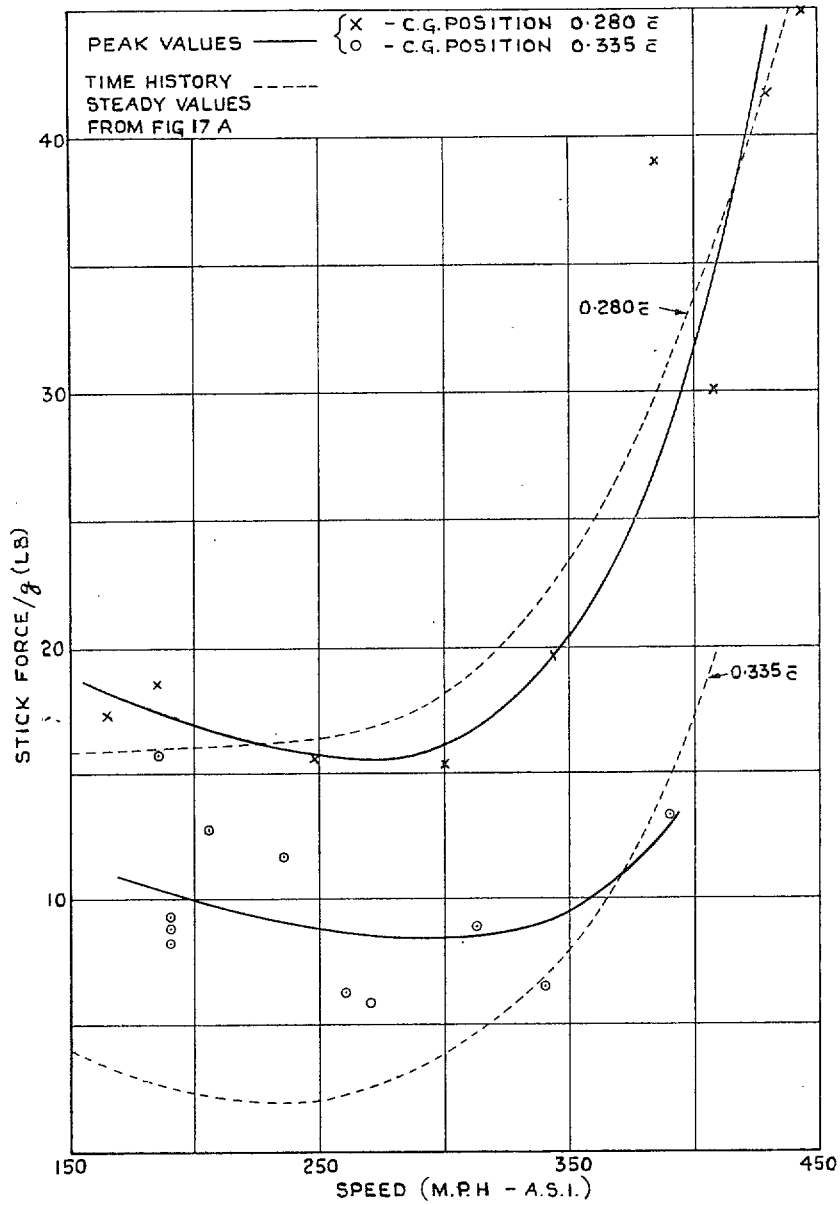

Fig. 27. A comparison of the steady and peak values of stick force/g against speed for two C.G. positions. Mosquito DZ 294.

Publications of the Aeronautical Research Council

ANNUAL TECHNICAL REPORTS OF THE AERONAUTICAL RESEARCH COUNCIL (BOUND VOLUMES)—

- 1934-35 Vol. I. Aerodynamics. *Out of print.*
Vol. II. Seaplanes, Structures, Engines, Materials, etc. 40s. (40s. 8d.)
- 1935-36 Vol. I. Aerodynamics. 30s. (30s. 7d.)
Vol. II. Structures, Flutter, Engines, Seaplanes, etc. 30s. (30s. 7d.)
- 1936 Vol. I. Aerodynamics General, Performance, Airscrews, Flutter and Spinning. 40s. (40s. 9d.)
Vol. II. Stability and Control, Structures, Seaplanes, Engines, etc. 50s. (50s. 10d.)
- 1937 Vol. I. Aerodynamics General, Performance, Airscrews, Flutter and Spinning. 40s. (40s. 10d.)
Vol. II. Stability and Control, Structures, Seaplanes, Engines, etc. 60s. (61s.)
- 1938 Vol. I. Aerodynamics General, Performance, Airscrews. 50s. (51s.)
Vol. II. Stability and Control, Flutter, Structures, Seaplanes, Wind Tunnels, Materials. 30s. (30s. 9d.)
- 1939 Vol. I. Aerodynamics General, Performance, Airscrews, Engines. 50s. (50s. 11d.)
Vol. II. Stability and Control, Flutter and Vibration, Instruments, Structures, Seaplanes, etc. 63s. (64s. 2d.)
- 1940 Aero and Hydrodynamics, Aerofoils, Airscrews, Engines, Flutter, Icing, Stability and Control, Structures, and a miscellaneous section. 50s. (51s.)

Certain other reports proper to the 1940 volume will subsequently be included in a separate volume.

ANNUAL REPORTS OF THE AERONAUTICAL RESEARCH COUNCIL—

1933-34	1s. 6d. (1s. 8d.)
1934-35	1s. 6d. (1s. 8d.)
April 1, 1935 to December 31, 1936.	4s. (4s. 4d.)
1937	2s. (2s. 2d.)
1938	1s. 6d. (1s. 8d.)
1939-48	3s. (3s. 2d.)

INDEX TO ALL REPORTS AND MEMORANDA PUBLISHED IN THE ANNUAL TECHNICAL REPORTS, AND SEPARATELY—

April, 1950 R. & M. No. 2600. 2s. 6d. (2s. 7½d.)

INDEXES TO THE TECHNICAL REPORTS OF THE AERONAUTICAL RESEARCH COUNCIL—

December 1, 1936 — June 30, 1939.	R. & M. No. 1850. 1s. 3d. (1s. 4½d.)
July 1, 1939 — June 30, 1945.	R. & M. No. 1950. 1s. (1s. 1½d.)
July 1, 1945 — June 30, 1946.	R. & M. No. 2050. 1s. (1s. 1½d.)
July 1, 1946 — December 31, 1946.	R. & M. No. 2150. 1s. 3d. (1s. 4½d.)
January 1, 1947 — June 30, 1947.	R. & M. No. 2250. 1s. 3d. (1s. 4½d.)

Prices in brackets include postage.

Obtainable from

HER MAJESTY'S STATIONERY OFFICE

York House, Kingsway, LONDON, W.C.2 429 Oxford Street, LONDON, W.1
P.O. Box 569, LONDON, S.E.1

13a Castle Street, EDINBURGH, 2 1 St. Andrew's Crescent, CARDIFF
39 King Street, MANCHESTER, 2 Tower Lane, BRISTOL, 1
2 Edmund Street, BIRMINGHAM, 3 80 Chichester Street, BELFAST

or through any bookseller.