

AERODYNAMIC PROPERTIES OF A HEMISPHERICAL
CUP. WITH APPLICATION TO THE HEMI-
SPHERICAL CUP, WINDMILL AND ANEMOMETER.

By F. B. BRADFIELD, of the R.A.E.

Presented by THE DIRECTOR OF RESEARCH.

Reports and Memoranda, No. 712. October, 1919.

SUMMARY.—(a) *Reasons for enquiry.*—Windmills of the hemispherical cup anemometer type have been used on aeroplanes for driving auxiliary apparatus, and it therefore appeared desirable to be able to calculate their performance. To do this it was necessary to know the forces on a cup, and as this data was not available, the present work was set in hand.

(b) *Range of investigation.*—The lift, drag, and yawing moments of a hemispherical cup have been measured at several values of lv . Hence the characteristic curves for a windmill of this type when used as a means of obtaining power have been deduced. Two fans were tested in the wind channels for comparison with the calculated results. The effect of shielding the half revolution of the cups during which they return against the wind was ascertained, both with the anemometer half shielded by sinking it in the side of a large body, and with a windguard exposed to the wind.

(c) *Results.*—For the unshielded windmill the agreement obtained between the experimental torque and thrust and the calculated curves is very close. With a guard an approximate curve has been calculated, which gives good general agreement with the experimental results for the windmill as sunk in the side of a large body. The case with the exposed guard gives considerably larger values of torque and thrust, which effect is shown to be explained by the disturbance in the flow due to the guard.

The aerodynamic properties of the cup, though investigated in this connection, are of more general interest and are therefore given in some detail.

A note on the Robinson Anemometer is appended.

Preliminary.—A small windmill of the hemispherical shell type (see Fig. 8) had been tested for the power obtainable, both with and without a windguard which shielded the return half of the revolutions of the cups. The h.p. obtainable was much higher with than without this windguard. It was therefore considered of interest to make calculations as to the behaviour of such a windmill under these conditions, but data as to the aerodynamic

properties of a hemispherical cup were not available. The experimental work described below comprises an investigation of the properties of a hemispherical cup; calculations from this data of the thrust, torque, and efficiency curves applicable to any fan of this type running as a windmill; and finally a comparison of these calculated curves with experimental measurements of thrust and torque on a windmill which was tested in the wind channels for this purpose.

1. *Test of hemispherical cup.*—The hemispherical cups were tested in the 4-ft. channel of the Royal Aircraft Establishment. Two cups of diameter 6 ins. and 3 ins. respectively were tested at speeds varying from 25 ft. per sec. to 55 ft. per sec. and a considerable range of lV was thus obtained. The 6-in. cup was of 22-gauge copper, and was mounted on a spindle attached to the cup $\frac{1}{4}$ in. from the rim, and mounted in the balance chuck as for a standard aerofoil test. Corrections were made for spindle drag and interference by the standard methods, and also for the bending of the spindle and cup.

The 3-in. cup was more rigid, and no bending correction was considered necessary. Lift, drag, and yawing moments were measured, in each case at intervals of 5° round the whole 360° , to correct for any lack of symmetry in the cup. The scale effect found was irregular, and it was decided to use the results of the test on the 6-in. cup at 50 ft./sec. throughout the further work. The normal force coefficients for various values of lV are shown in Fig. 2. The lift, drag, and normal force coefficients of the 6-in. cup at 50 ft./sec. are shown in Fig. 3. The drag is of interest, as the type of flow changes very obviously just before $\theta = 50^\circ$, the balance reading first having two values between which it oscillates, and then steadying up as 50° is reached on to a higher curve. The maximum lift occurs at this same angle. The yawing moment is small throughout. From the lift, drag, and moment, the movement of the C.P. has been calculated and its distance from the centre of the cup as a fraction of the diameter tabulated and plotted (see Fig. 4). Looking at Figs. 3 and 4 together, it will be seen that the C.P. is sensibly at the centre of the cup whenever the normal force is sufficiently large to be of importance. The normal force may therefore be taken to act throughout at the centre of the cup in deducing the performance of windmills.

2. *Characteristic curves for windmill.*—*Notation.*

V = velocity of wind.

n = revs. per sec.

r = distance of centre of cup from axis of rotation.

$cV = 2\pi nr$ = velocity of rotation of centre of cup.

θ = angle of rotation of cup (see Fig. 8).

$V' = \text{relative wind} = V(1 + c^2 - 2c \cos \theta)^{\frac{1}{2}} = VC,$
 where $C^2 = 1 + c^2 - 2c \cos \theta.$

$\varphi = \text{angle between } V \text{ and } V'.$

$A = \frac{\pi}{4} d^2$ where d is diameter of cup.

$k_v = \text{force coefficient along direction } V = k_n \cos \varphi + k_t \sin \varphi.$

$k_n = \text{normal force coefficient.}$

$B = \text{number of cups.}$

The mean torque over a complete revolution is

$$Q = B\rho AV^2 r \frac{1}{2\pi} \int_0^{2\pi} C^2 k_n d\theta$$

and the mean thrust

$$T = B\rho AV^2 \frac{1}{2\pi} \int_0^{2\pi} C^2 k_v d\theta$$

From Fig. 8 it will be seen that the yaw of the cup to the relative wind is $\theta + \varphi$. φ was worked out for $c = \frac{2\pi r n}{V} = 0, 0.1, 0.2, 0.3 \dots$ and $\theta = 0^\circ, 10^\circ, 20^\circ \dots 180^\circ$ and C^2 was also tabulated for this same range of $\theta + \varphi$. k_n was read off at an angle $\theta + \varphi$ and $k_n C^2$ is plotted against θ in Fig. 5. k_t and k_p were read off at $\theta + \varphi$ and $k_v = k_p \cos \varphi + k_t \sin \varphi$ tabulated and $k_v C^2$ is plotted against θ in Fig. 6. From the areas of these curves are deduced the thrust and torque coefficients, $T/B\rho AV^2$ and $Q/B\rho AV^2 r$, applicable to any windmill of this type. This gives the characteristic curves of the unshielded windmill, which are shown plotted in Fig. 7.

This theory can only be expected to give approximate agreement, as many factors have been neglected. It is analogous to propeller calculations based on the aerofoil theory with no corrections. Four corrections are :—

- (1) Interference of the cups on one another. The size of this might be estimated by testing an anemometer with two and four cups. This has not been done.
- (2) It has been assumed that if $2\pi r n$ is taken as the value of the rotational velocity over the whole cup, this will give the correct mean thrust and torque over the cup, r being the radial distance of the centre of the cup.
- (3) The spindles carrying the cups have been neglected. A correction for spindles might be applied to any anemometer in which it is likely to be appreciable.
- (4) Scale effect is neglected. The lift and drag coefficients for the hemispherical cup at an lV of 24 (where $l = \text{diameter of cup}$) have been used throughout.

The efficiency of the windmill is greatly increased by shielding the return of the cups by a windguard. This case presents some difficulties from the point of view of calculation. Several alternative assumptions might be made as to the behaviour of the air, such as :—

- (a) The air in the guard may be assumed still, and the torque in the guard calculated for the rotational speed of the cups.
- (b) The air may rotate in the guard in the direction of rotation of the cups with a velocity proportional to that of the cups and not disturb the air outside the guard, through which the cups pass.
- (c) The air may rotate inside the guard as in case (b), and return in a circular path, forming a circular rotation of the air superposed on the steady velocity V of the wind. This has the effect of reducing the value of c .

Case (a) would be approached with a large guard and small cups on long spindles, as no appreciable rotation of air inside the guard would then be set up. In case (b) the air carried round by the cups must return across the top of the guard, but below the path of the cups. In a guard which only just gives clearance for the cups the air will certainly be carried round inside the guard, and though the flow will not be so simple as that suggested under (b) or (c) above, the actual result may lie between the values calculated on these two assumptions.

In any case the larger part of the thrust and torque will be given by the half revolution of the cups outside the guard : that is by :—

$$\frac{Q}{\rho AV^2 r} = B \frac{2}{\pi} \int_{\frac{\pi}{2}}^{\pi} C^2 k_x d\theta$$

and

$$\frac{T}{\rho AV^2} = B \frac{2}{\pi} \int_{\frac{\pi}{2}}^{\pi} C^2 k_v d\theta$$

which are found from Figs. 5 and 6 by integrating from 0° to 90° . The return half revolution of the cups will decrease the torque, while the flow back of air which has been carried round by the cups will increase it ; and as these tend to cancel one another, the expression for the torque of the exposed half revolution given above may be a fairly good approximation to the total torque. It is this torque which is plotted below (Figs. 7 and 10) as the calculated torque. In the case of the thrust, both the effects mentioned above would increase the thrust ; and as the thrust plotted below (Figs. 7 and 11) is the thrust of the exposed half revolution only, it may be expected to lie below the experimental

points. No correction has been made, since the exact flow depends on the details of the guard, and the more exact prediction of thrust for one special guard is of small interest.

So far the disturbance of the flow due to the windguard has not been considered. When mounted on an aeroplane to drive auxiliary apparatus, the windmill may be let into the side of the body, and in this case the wind striking the cups will be approximately parallel to the surface in which the windmill is sunk, and there is no additional drag for the windguard nor disturbance due to it. If, however, a guard of the type shown in Fig. 8 is exposed to the wind, there will be the constant drag of the guard to be added to the thrust, and also the flow will be different.

Comparison of the above results with the windmills tested.—The two windmills tested were:—

A. *Small windmill.* $r = 1.57''$, $d = 0.875''$.

This was tested for torque only, in the No. 1 7-ft. channel, at $V = 70$ and 80 ft. per sec.

B. *Large windmill.* $r = 8''$, $d = 4.07''$.

Tested for thrust and torque in the 4-ft. channel at $V = 35, 45,$ and 50 ft/sec.

An allowance must be made for the friction torque of the fans. Let Q' be the measured torque, Q_F the friction torque assumed constant, and $Q = Q' + Q_F$ the total torque. If the curves for Q' at different speeds are plotted against nr/V , they will meet at some negative value of Q' , where the total torque for all speeds is zero. This negative value of Q' gives the friction torque.

In Figs. 9 and 11A the torque and thrust for a windmill with four cups are plotted. The curve in each case is the calculated curve, and the points are experimental points. The efficiency is given in Fig. 12A. The agreement is very close—more so than could be expected from so approximate a theory.

Both the windmills were tested with an exposed windguard (1) of the type shown in Fig. 8. Windmill B was also tested with two other arrangements of the windguard (2) and (3), which represented the windmill as it is mounted in the side of a Handley Page machine. The side of the machine was represented by a large board mounted horizontally in the channel, and an outer guard shielded the windguard. In the arrangement denoted by (2) the top of the windguard was open, while in the case (3) the top was closed except for a dumb-bell shaped opening which just allowed clearance for the windmill to revolve.

The difference between cases (1) and (2) gives a measure of the disturbance of the air due to the guard, while the partial

blocking of the top of the guard in (3) may affect the velocity of rotation of the air in the guard. The results are plotted in Figs. 10, 11*b*, and 12*b*, in which the points are in each case experimental points, while the lines are calculated curves as explained above.

Considering cases (2) and (3) first, as these are the simplest, the experimental torque agrees pretty well with the calculation except at very high and very low values of nr/V . The experimental thrust lies on the whole above the curve, as was expected. The efficiency is in consequence lower than the calculated value. But on the whole the agreement is sufficiently good for the approximate curve given to be of use as a basis for predicting results. The torque is unaltered by the partial closing of the top of the guard, while the thrust is decreased at low values of nr/V .

Case (1), however, differs markedly from the others. The torque is considerably higher; and the thrust of the cups is higher than in the other cases, in addition to which the drag of the guard must be added. In Fig. 11*b*, the thrust plotted is that of the cups only, for comparison with that of the cups in the other cases. The drag of the guard, $T'/\rho AV^2 = 0.253$, must be added to the plotted results. The drag of the frame necessary to support the apparatus was of necessity large, and no great reliance can therefore be put on the figure given for the drag of the cups when this latter is small.

To explain these results the flow round the windguard must be taken into account. A pressure head mounted above the windguard of B when the cups had been removed showed that the air through which the cups pass is speeded up by about 5.5 per cent. parallel to its initial motion. In addition to this, there is an upward pitch of the air at the front rim of the guard, and a downward pitch at the back. Rough measurements of this were taken by attaching threads to the guard rim, and to wires above it. The pitch at the front rim was 15° , but the air quickly straightened out again, while at the back rim the threads flapped through a large angle. A rough calculation was made on these data, and it is estimated that the torque is increased 6 or 7 per cent. by this pitch. The choke effect of the channel for an object of this size should be rather less than 1 per cent., so the experimental points should be lowered on this account, while the calculated curve should be increased by about 17 per cent. on the grounds given above. This accounts for the discrepancy between this exposed guard and the others. This rough estimate of the windguard effect was made to account in a general way for the high torque found; but it would not be applicable to a windmill with a slightly different guard, and is so of minor interest. It will not, for instance, bring the similar case for windmill A into agreement—here the windmill was smaller and the guard was larger in proportion to the cups. The instrument is not therefore of sufficiently general interest to justify more detailed consideration of it.

It has been shown that the properties of the unshielded windmill can be predicted with good accuracy, and more approximately the properties of the shielded windmill when the form of shielding is such as not to alter the flow to any great extent, while a general explanation has been given of the results found in that case in which the guard does affect the flow.

Though the hemispherical cup was investigated in this particular connection, it is of more general interest than the rest of this report; for example, in connection with the motion of parachutes.

TABLE 1.

6-IX. HEMISPHERICAL CUP. $V = 50$ ft/sec.

θ	k_s	k_L	k_N	Moment lbs/ft. at $V = 50$.	C.P. Coefficient.
0	0.751	0.000	0.751	0.0000	0.000
5	0.767	0.079	0.770	0.0002	0.000
10	0.751	0.148	0.767	0.0006	0.002
15	0.750	0.227	0.782	0.0011	0.002
20	0.746	0.302	0.803	0.0018	0.003
25	0.749	0.393	0.835	0.0022	0.003
30	0.730	0.502	0.884	0.0027	0.002
35	0.717	0.567	0.914	0.0027	0.003
40	0.671	0.622	0.917	0.0026	0.002
45	0.626	0.660	0.911	0.0018	0.002
50	0.702	0.738	1.018	+ 0.0003	0.003
55	0.614	0.602	0.923	- 0.0005	0.005
60	0.517	0.624	0.808	- 0.0016	0.005
65	0.413	0.536	0.662	- 0.0023	0.005
70	0.321	0.431	0.516	- 0.0026	0.005
75	0.249	0.331	0.384	- 0.0027	+ 0.005
80	0.182	0.228	0.260	- 0.0029	- 0.002
85	0.112	+ 0.115	+ 0.125	- 0.0020	- 0.007
87					- 0.057
89					- 0.450
90	0.094	- 0.017	- 0.017	- 0.0032	+ 0.062
95	0.104	- 0.045	- 0.055	- 0.0032	0.016
100	0.115	+ 0.032	+ 0.012	- 0.0034	0.032
105	0.162	0.117	0.071	- 0.0035	0.037
110	0.189	0.132	0.058	- 0.0037	0.060
115	0.212	0.142	0.039	- 0.0039	0.092
120	0.226	0.151	+ 0.018	- 0.0042	0.258
123					+ 0.55
125	0.242	0.162	- 0.005	- 0.0043	- 0.85
130	0.249	0.173	- 0.029	- 0.0045	- 0.43
135	0.258	0.178	- 0.056	- 0.0047	- 0.085
140	0.258	0.179	- 0.081	- 0.0048	- 0.055
145	0.250	0.174	- 0.105	- 0.0047	- 0.040
150	0.242	0.160	- 0.129	- 0.0042	- 0.028
155	0.228	0.142	- 0.147	- 0.0039	- 0.015
160	0.214	0.120	- 0.159	- 0.0032	- 0.012
165	0.199	0.100	- 0.167	- 0.0027	- 0.006
170	0.183	0.070	- 0.169	- 0.0019	- 0.003
175	0.178	0.036	- 0.174	- 0.0014	+ 0.060
180	0.188	0.000	- 0.188	0.0000	0.000

TABLE 2.
CALCULATED TORQUE, THRUST, AND EFFICIENCY
OF WINDMILL. With Four Cups.

B = 4		No Guard.		
c	nr/V	$Q/\rho AV^2 r$	$T/\rho AV^2$	η
0	0	1.244	1.508	0
0.1	0.0159	0.952	1.412	6.75
0.2	0.0319	0.640	1.368	9.36
0.3	0.0478	0.348	1.316	7.82
0.4	0.0638	+ 0.114	1.332	3.44
0.5	0.0797	- 0.122	1.352	- 4.52

B = 4		With Guard.		
c	nr/V	$Q/\rho AV^2 r$	$T/\rho AV^2*$	η
0	0	1.400	1.112	0
0.1	0.0159	1.128	0.936	12.1
0.2	0.0319	0.852	0.772	22.1
0.3	0.0478	0.622	0.628	29.7
0.4	0.0638	0.464	0.508	36.6
0.5	0.0797	0.322	0.408	39.5

* N.B.—The thrust is that of the cups only—and does not include thrust due to the guard; consequently the efficiency here given is only applicable when there is no additional thrust due to the guard.

TABLE 3.

A. SMALL WINDMILL.

(a) Without Guard.

V ft./sec.	nr/V	Q'	$Q' + Q_f = Q$	$Q/\rho AV^2 r$
70	0.00421	4.38×10^{-3}	6.94	1.091
	0.00857	3.91	6.47	1.017
	0.0129	3.44	6.00	0.944
	0.0169	2.96	5.52	0.867
	0.0213	2.49	5.05	0.795
	0.0256	2.02	4.58	0.720
	0.0296	1.55	4.11	0.646
80	0.0334	2.49	5.05	0.608
	0.0302	2.96	5.52	0.664
	0.0233	3.91	6.47	0.779
	0.0196	4.38	6.94	0.835
	0.0159	4.85	7.41	0.892
	0.0122	5.33	7.89	0.950
	0.0090	5.80	8.36	1.006

(b) With Guard.

V ft./sec.	nr/V	Q'	Q	$Q/\rho AV^2 r$
70	0.0085	8.63	11.19×10^{-3}	1.76
	0.0199	7.68	10.24	1.61
	0.0307	6.74	9.30	1.46
	0.0403	5.80	8.36	1.32
	0.0478	4.85	7.41	1.17
	0.0544	3.91	6.47	1.02
80	0.0402	7.68	10.24×10^{-3}	1.24
	0.0381	8.15	10.71	1.29
	0.0339	8.63	11.19	1.35
	0.0317	9.10	11.66	1.41
	0.0281	9.57	12.13	1.46
	0.0251	10.04	12.60	1.52
	0.0190	10.51	13.07	1.58
	0.0132	11.00	13.56	1.64

Friction Torque $Q_f = 2.56 \times 10^{-3}$ $d = 0.875'' \quad r = 1.57''$

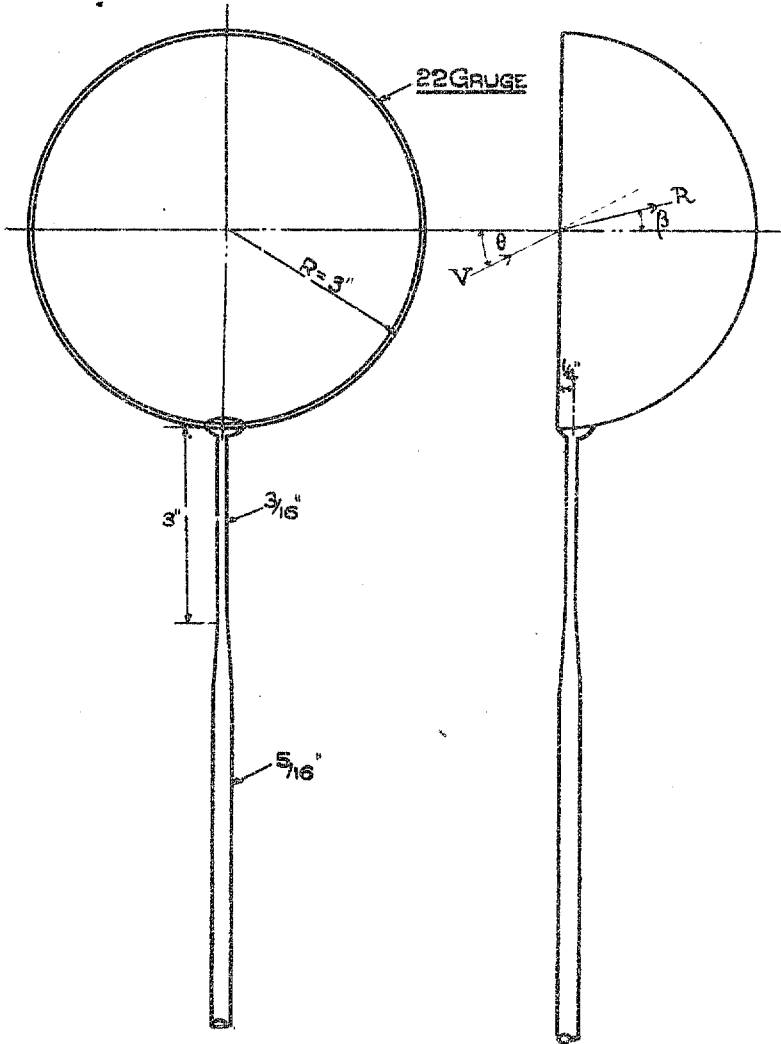

HEMISPHERICAL CUP 6" DIAMETER

REPORT N° 712.

NORMAL FORCE OF HEMISPHERICAL

FIG 2.

CUP FOR DIFFERENT VALUES OF LV

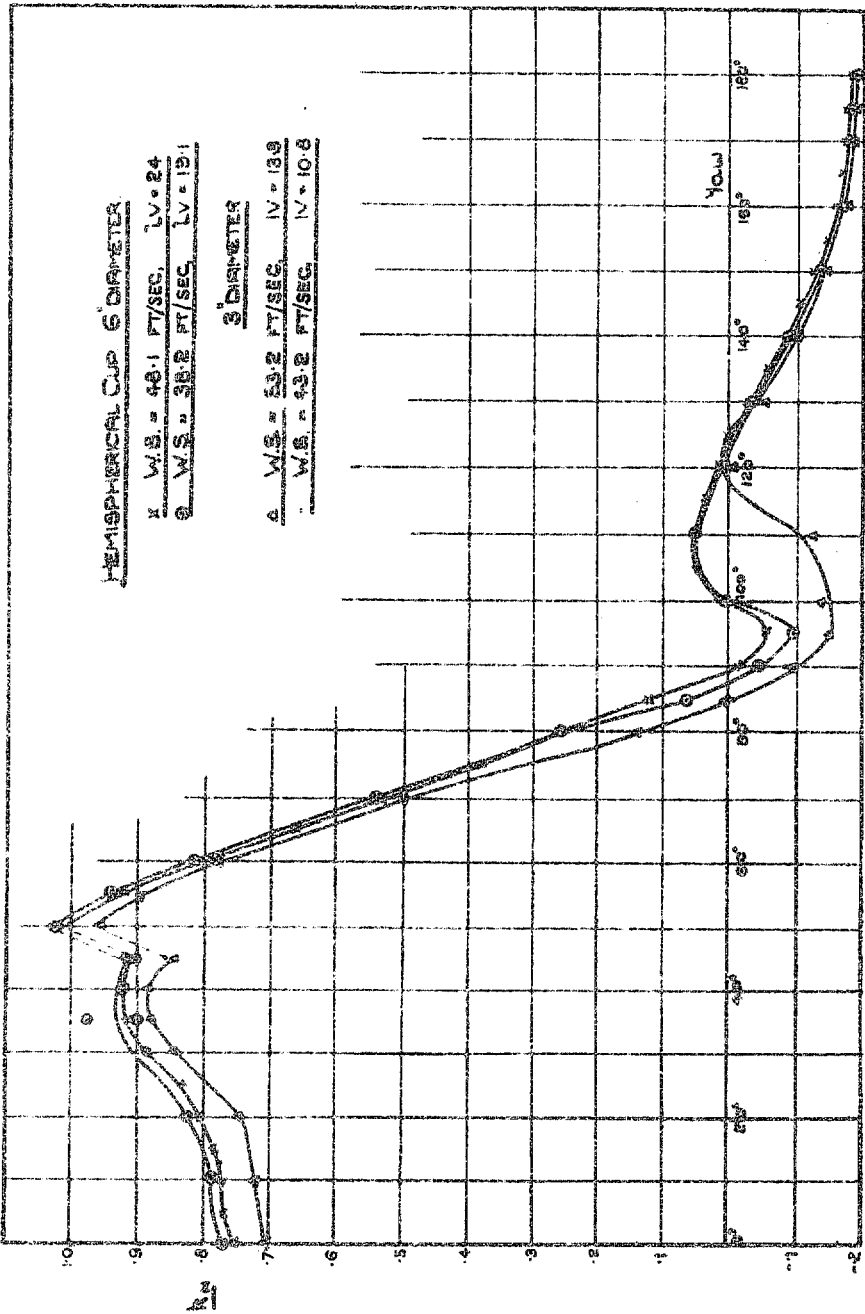

LIFT, DRAG, & NORMAL FORCE COEFF^{TS}

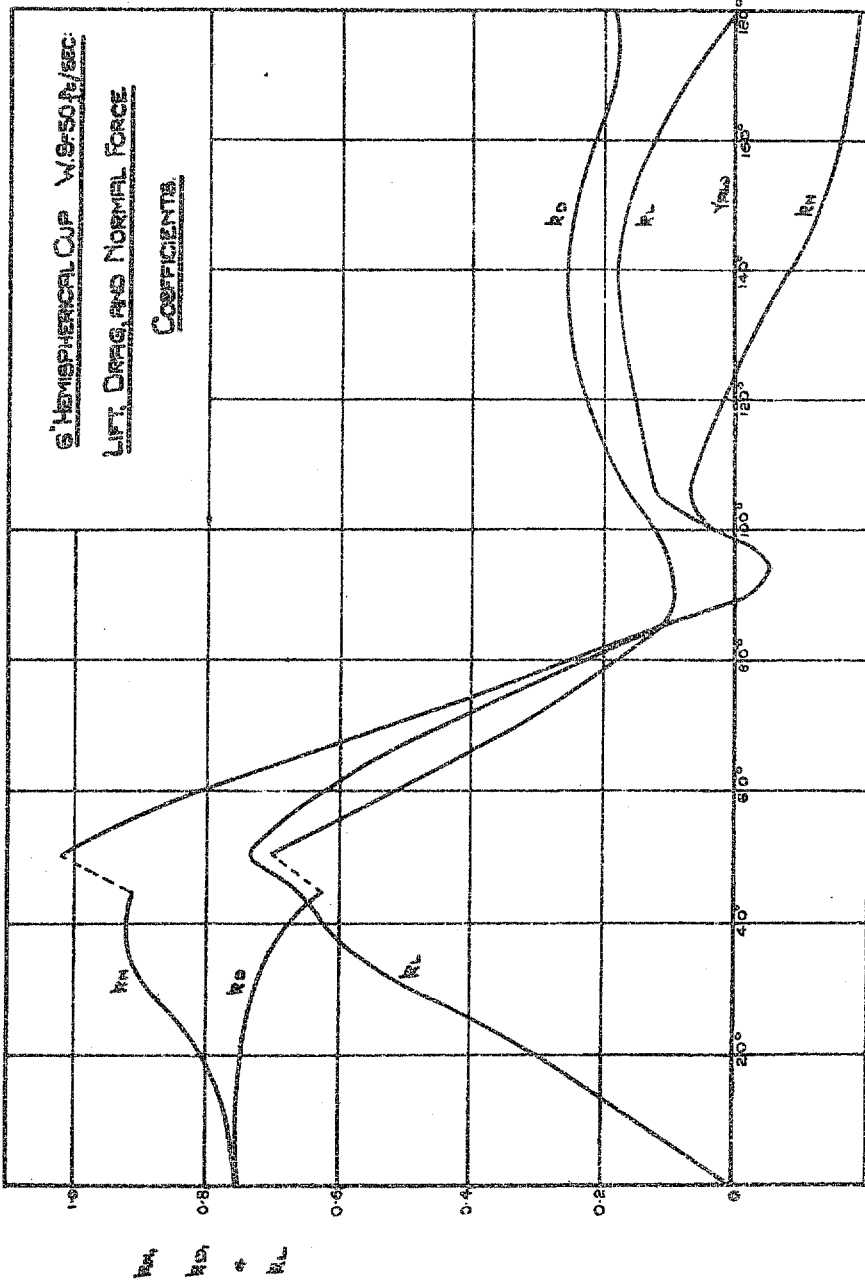

HEMISPHERICAL CUP

YAWING MOMENT, & MOVEMENT OF CENTRE OF PRESSURE
WITH YAW.

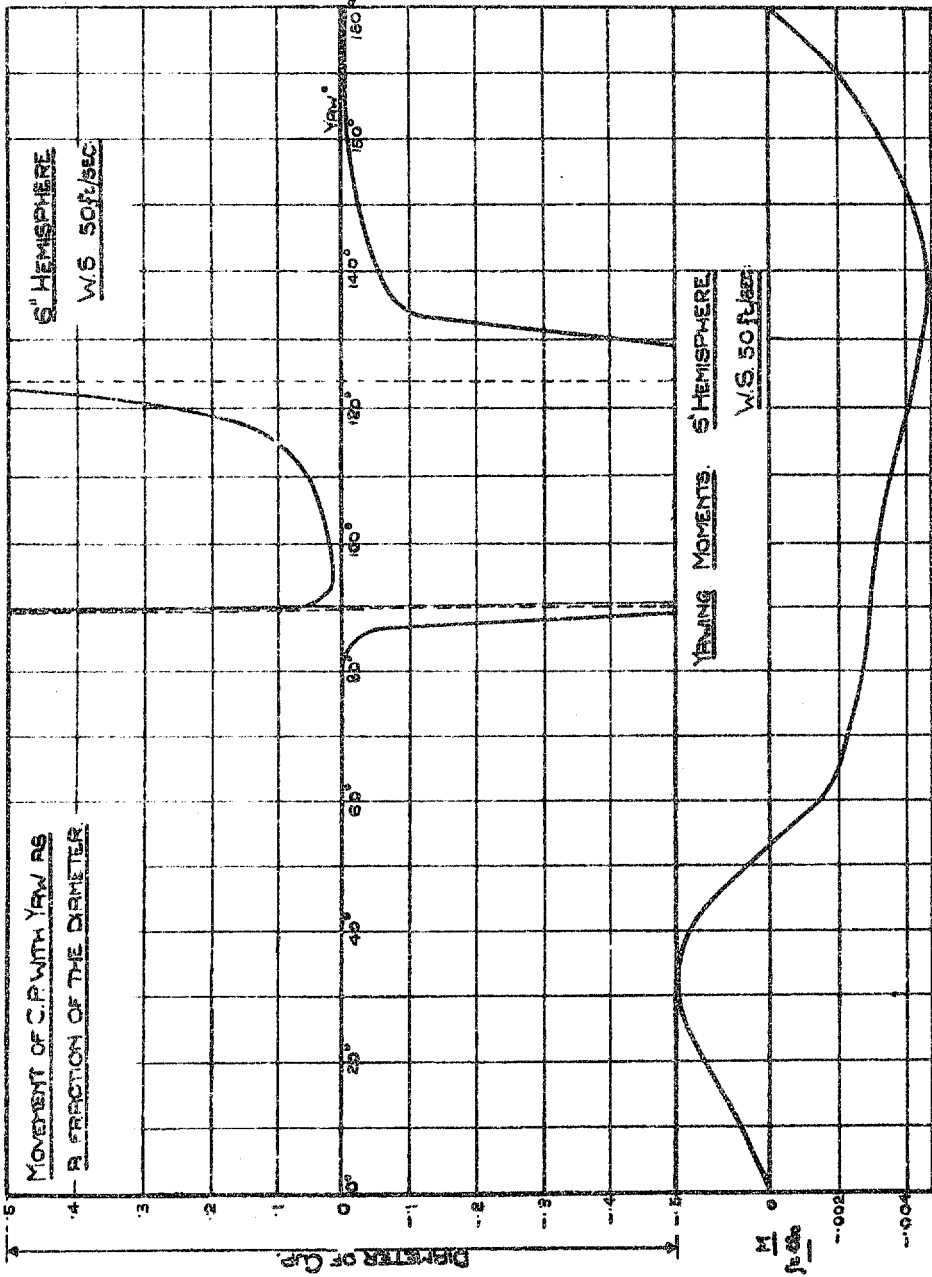

TORQUE OF HEMISPHERICAL CUP WINDMILL.

FIG. 5

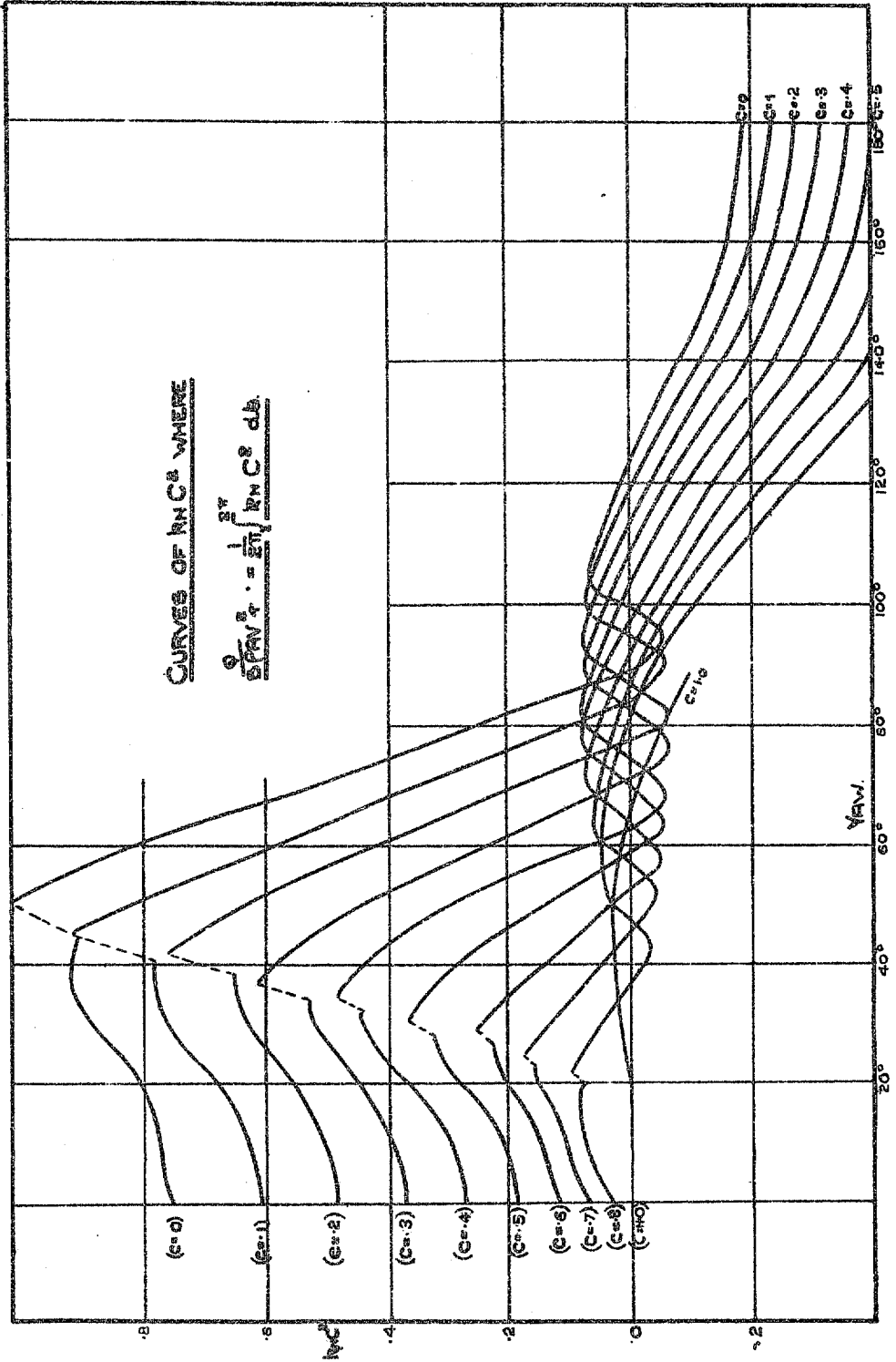

THRUST OF HEMISPHERICAL CUP WINDMILL.

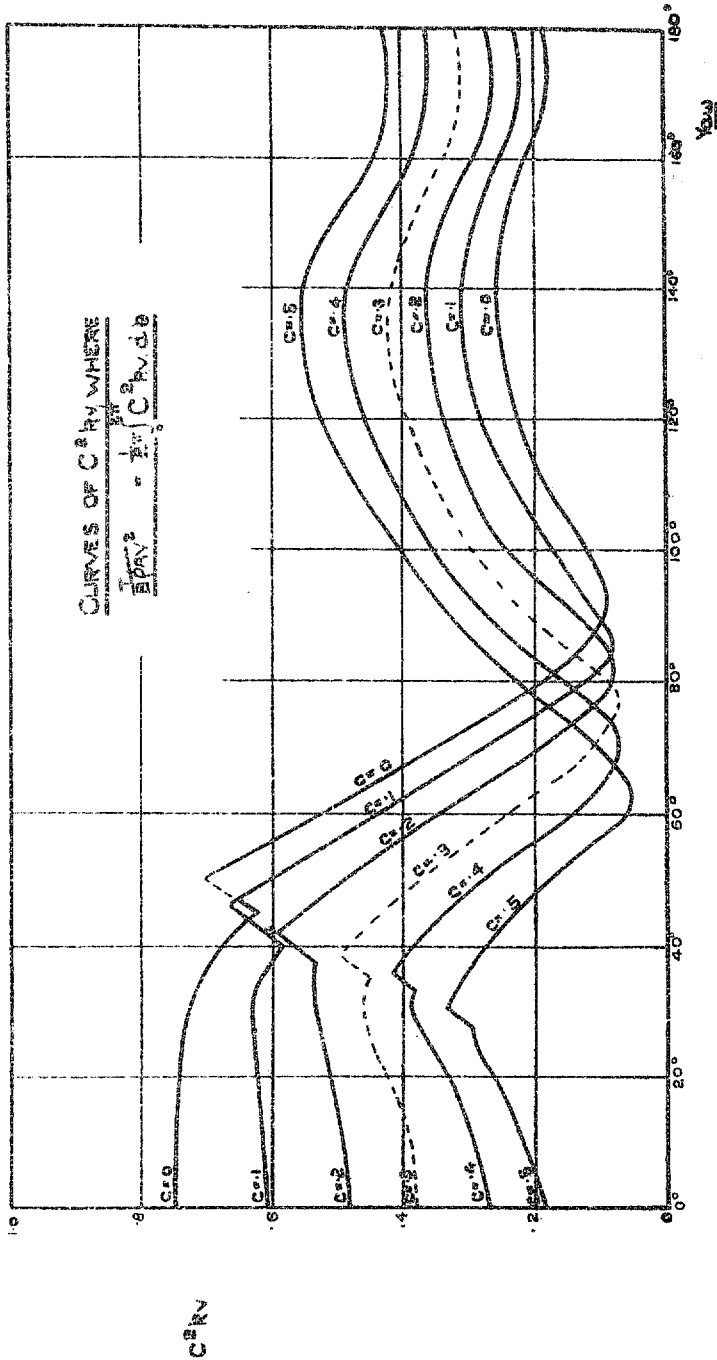

CHARACTERISTIC CURVE FOR WINDMILL.

EFFICIENCY

η

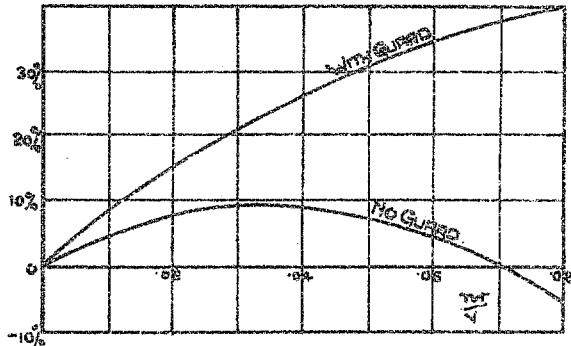

THRUST

$\frac{T}{\rho A V^2}$

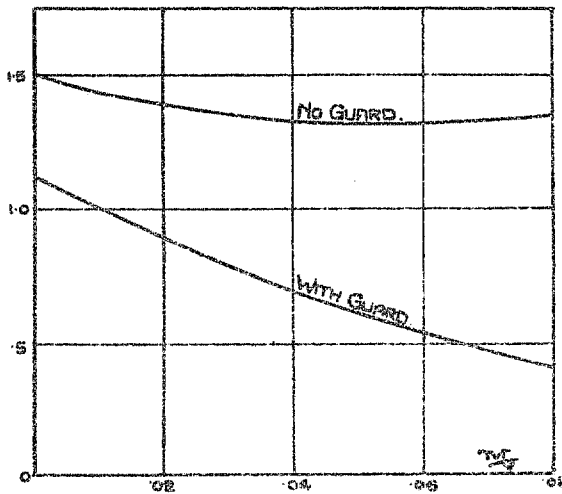

TORQUE

$\frac{Q}{\rho A V^3}$

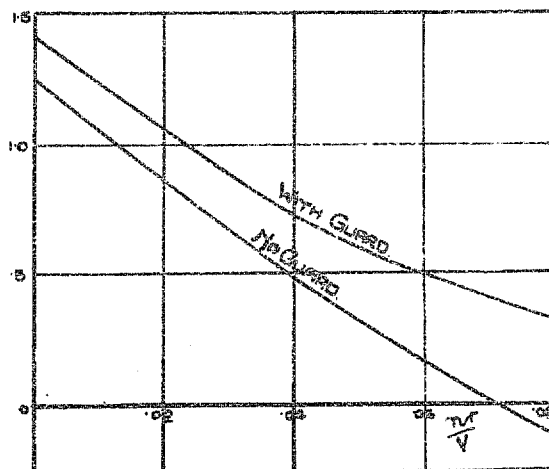

B. THE NO OF CUPS IS TAKEN AS 4.

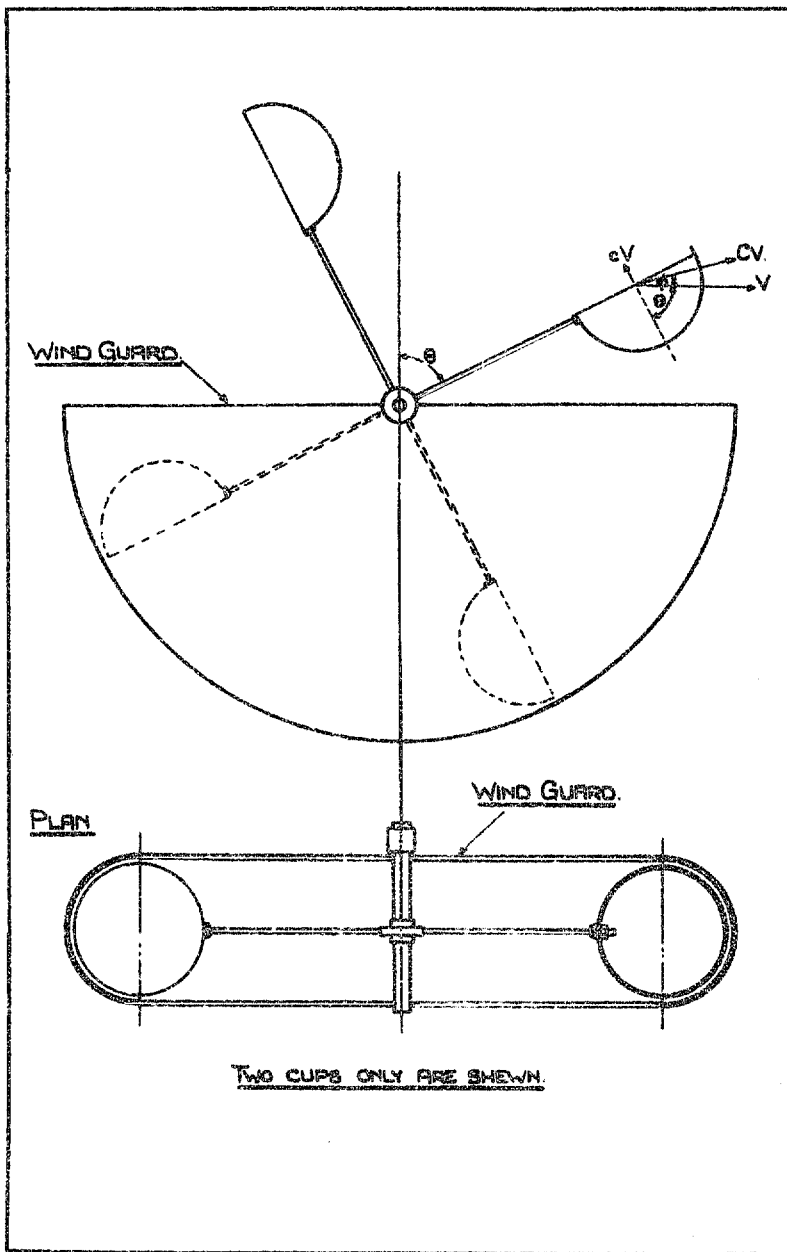

DIAGRAM OF THE HEMISPHERICAL CUP.

WINDMILL B.

TORQUE OF WINDMILL.

NO GUARD.

A SMALL WINDMILL.

B. LARGE WINDMILL.

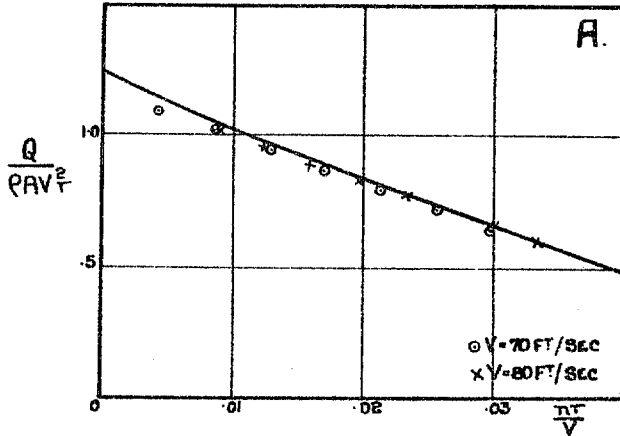

THE POINTS ARE EXPERIMENTAL POINTS.

THE CURVES ARE THE CALCULATED TORQUE CURVE.

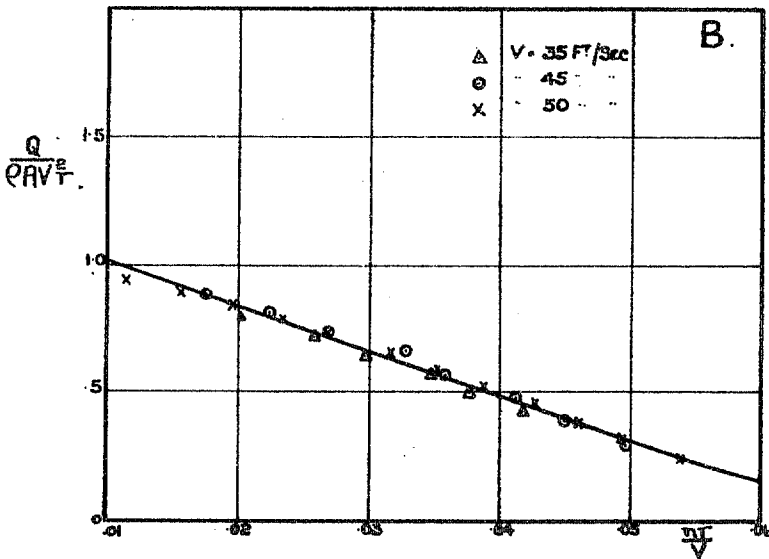

TORQUE OF WINDMILLS
WITH WIND GUARDS.

WINDMILL A.

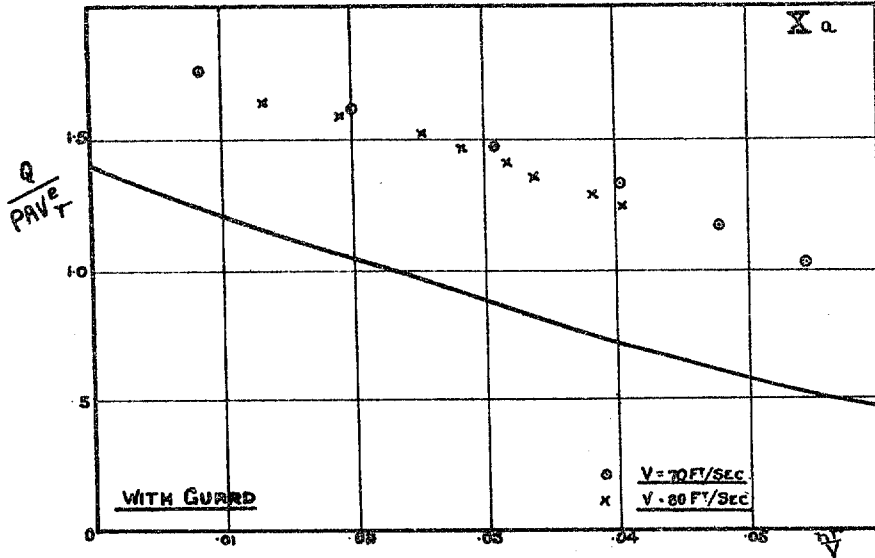

THE POINTS ARE EXPERIMENTAL POINTS.

THE LINES ARE THE CALCULATED CURVES.

WINDMILL B.

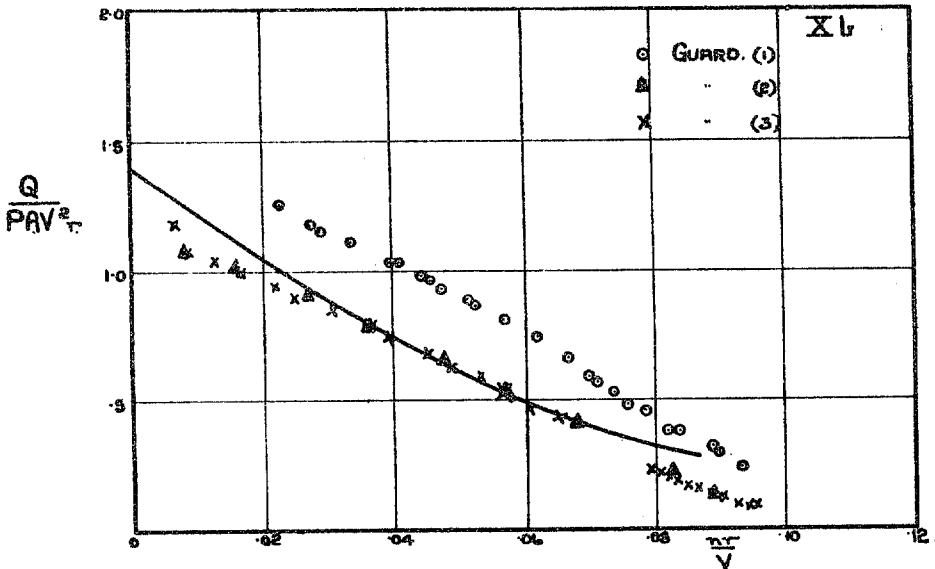

THRUST OF WINDMILL B.

THE LINES ARE THE CALCULATED CURVES.

THE POINTS ARE EXPERIMENTAL POINTS.

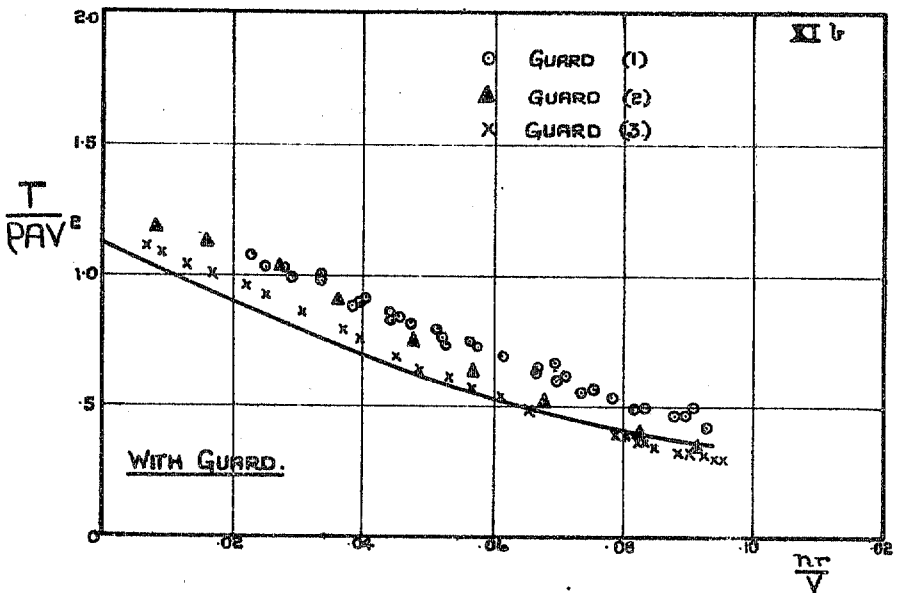
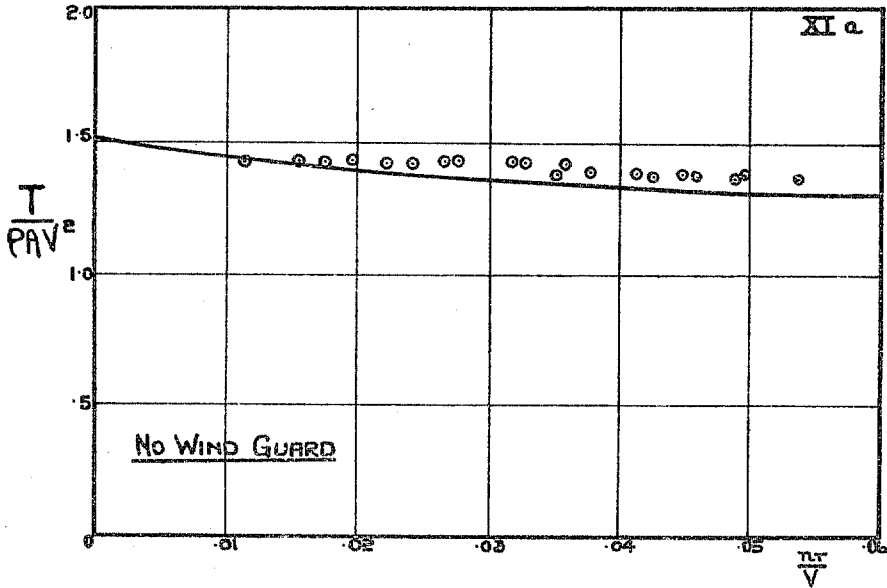

EFFICIENCY OF WINDMILL B.

THE LINES ARE CALCULATED CURVES.

THE POINTS ARE EXPERIMENTAL POINTS.

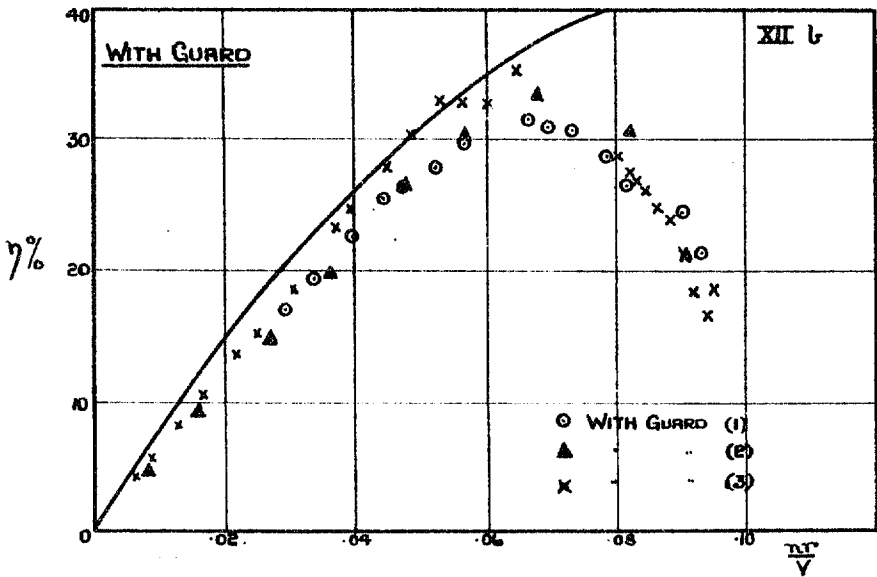
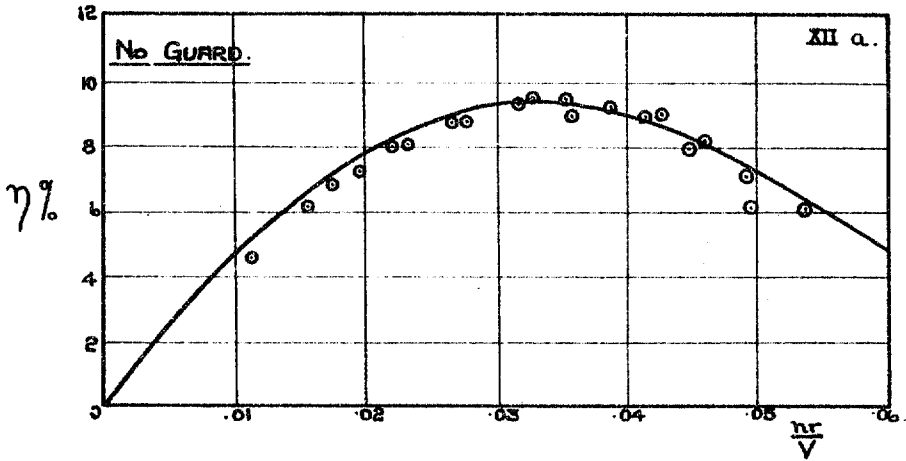

VARIATION OF FACTOR OF ROBINSON ANEMOMETER.
WITH TORQUE.

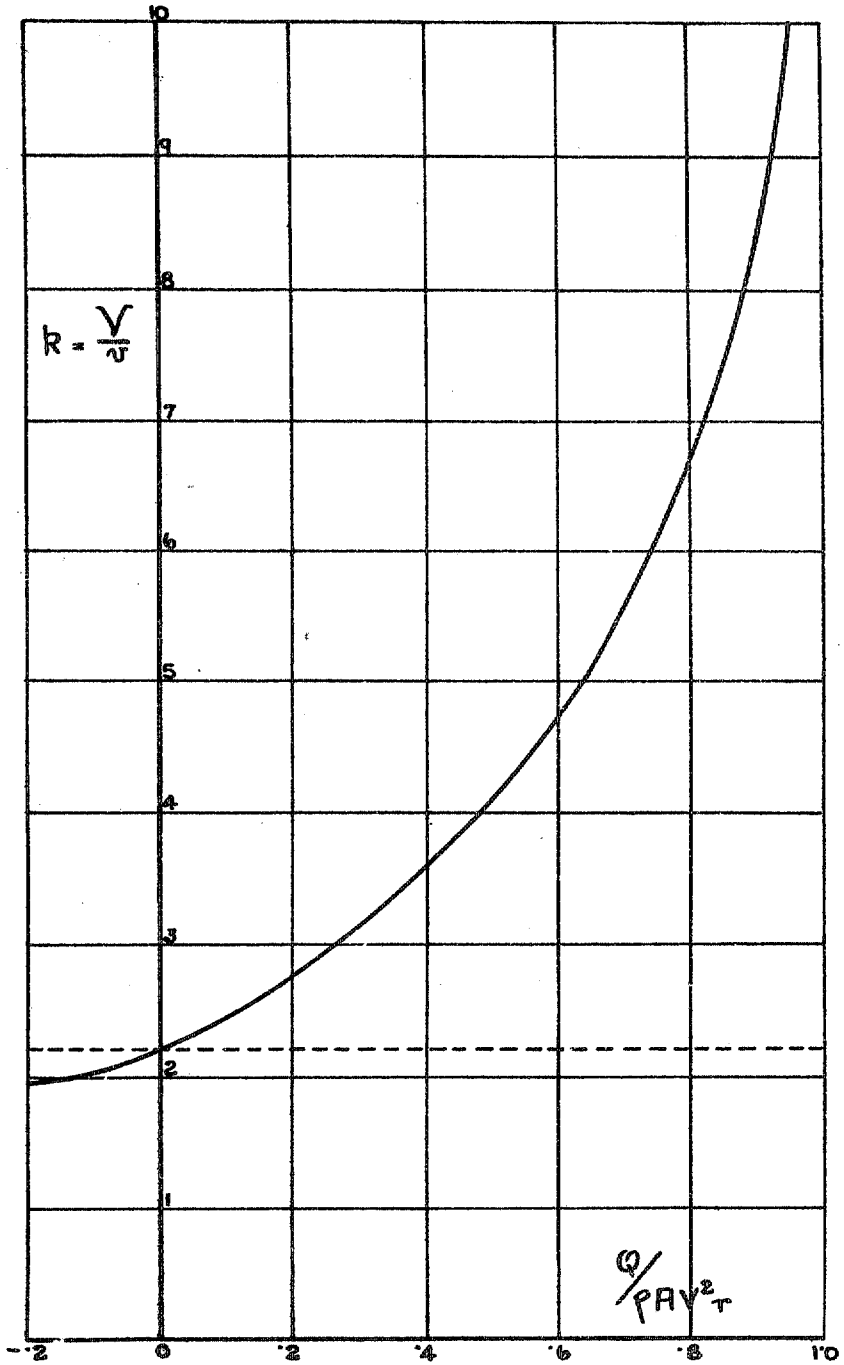

VARIATION OF FACTOR OF ROBINSON ANEMOMETER.
WITH V.

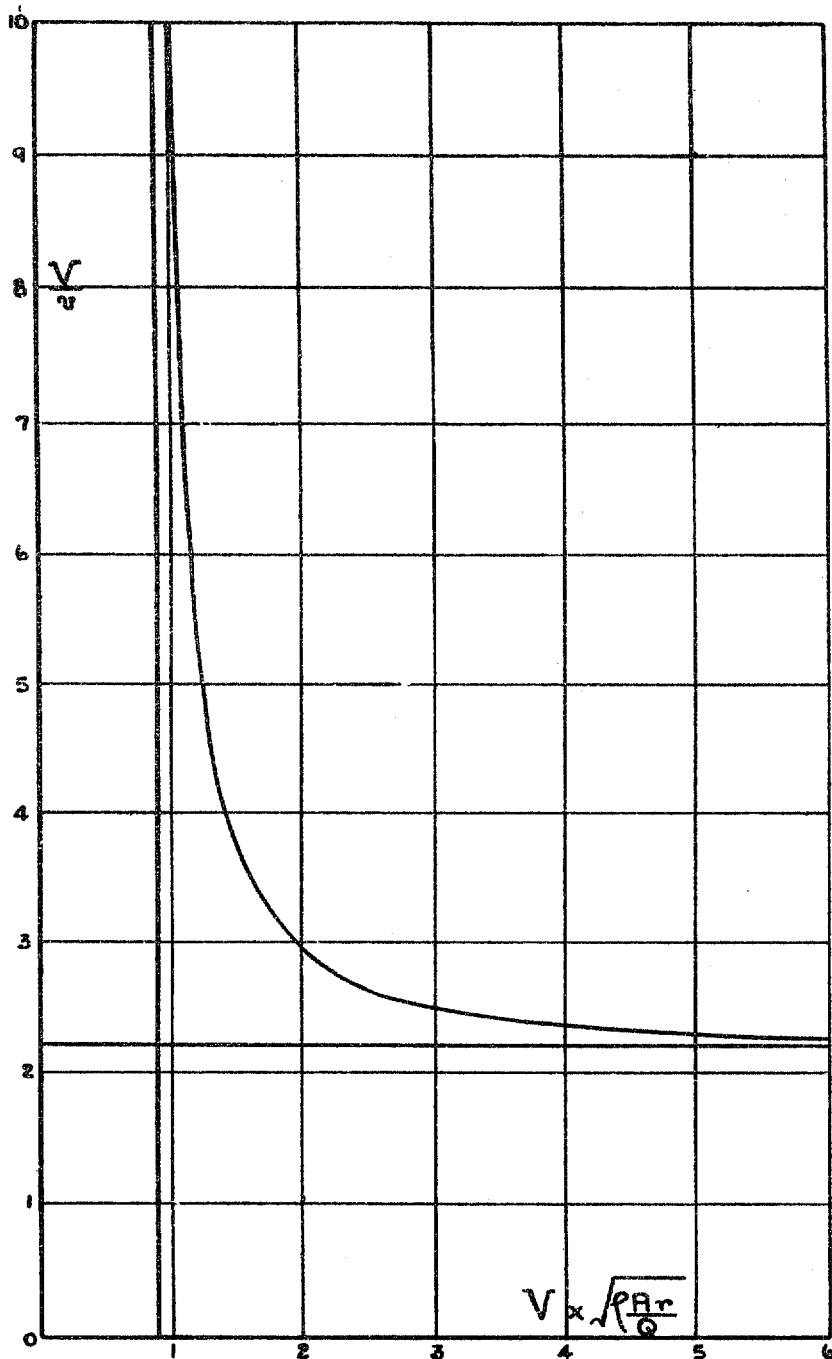

TABLE 4.
WINDMILL B.

No Guard.

Guard (1)

V ft/sec.	$\frac{nr}{V}$	$\frac{Q}{\rho AV^2 r}$	$\frac{T}{\rho AV^2}$	η	V ft/sec.	$\frac{nr}{V}$	$\frac{Q}{\rho AV^2 r}$	$\frac{T}{\rho AV^2}$	$\frac{T+T'}{\rho AV^2}$	η
35	0.0419	0.421			35	0.0908	0.495	0.492		
	0.0376	0.494				0.0695	0.641	0.669		
	0.0347	0.567				0.0613	0.787	0.691		
	0.0299	0.643				0.0524	0.935	0.726		
	0.0257	0.708				0.0442	1.077	0.826		
	0.0202	0.781				0.0384	1.208	0.884		
					0.0252	1.329	1.039			
45	0.0496	0.300	1.388	6.1	45	0.0898	0.300	0.456		
	0.0448	0.388	1.386	7.9		0.0836	0.388	0.490		
	0.0413	0.476	1.388	8.9		0.0755	0.476	0.568		
	0.0359	0.566	1.426	8.9		0.0711	0.566	0.607		
	0.0328	0.654	1.426	9.5		0.0665	0.651	0.648		
	0.0267	0.736	1.426	8.7		0.0615	0.731	0.698		
	0.0222	0.807	1.426	7.9		0.0563	0.804	0.740		
	0.0175	0.881	1.426	6.8		0.0516	0.893	0.796		
50	0.0536	0.243	1.371	6.0		0.0405	1.049	0.911		
	0.0493	0.314	1.375	7.1		0.0338	1.128	0.967		
	0.0460	0.386	1.375	8.1		0.0279	1.194	1.027		
	0.0427	0.458	1.378	9.0		0.0228	1.256	1.086		
	0.0389	0.527	1.390	9.3	50	0.0934	0.243	0.420	0.673	21.2
	0.0353	0.593	1.383	9.5		0.0885	0.314	0.458	0.711	24.5
	0.0318	0.664	1.433	9.3		0.0819	0.386	0.498	0.751	26.4
	0.0276	0.723	1.434	8.7		0.0783	0.458	0.529	0.782	28.8
	0.0234	0.783	1.434	8.0		0.0738	0.527	0.545	0.798	30.6
	0.0197	0.841	1.434	7.2		0.0698	0.598	0.598	0.851	30.8
	0.0155	0.894	1.434	6.1		0.0666	0.669	0.636	0.889	31.5
	0.0111	0.931	1.434	4.5		0.0571	0.804	0.722	0.975	29.6
				0.0523		0.863	0.768	1.021	27.8	
				0.0476		0.931	0.808	1.061	26.3	
				0.0444		0.997	0.847	1.100	25.3	
				0.0395		1.044	0.896	1.149	22.6	
				0.0339	1.112	0.967	1.220	19.4		
				0.0292	1.157	0.996	1.249	17.0		

Friction torque = 0.061
A = 0.0904 sq. ft.
r = 8 ins.

The thrust $\frac{T}{\rho AV^2}$ given for guard
(1) is the thrust of the cups only.
The thrust on the guard is
 $T'/\rho AV^2 = 0.253.$

TABLE 4—continued.
LARGE WINDMILL B.

With Guard (2).

With Guard (3).

V ft/sec.	$\frac{nr}{V}$	$\frac{Q}{\rho AV^2 r}$	$\frac{T}{\rho AV^2}$	η	V ft/sec.	$\frac{nr}{V}$	$\frac{Q}{\rho AV^2 r}$	$\frac{T}{\rho AV^2}$	η
50	0.0911	0.123	0.333	21.1	50	0.0955	0.092	0.299	18.4
	0.0827	0.229	0.389	30.5		0.0945	0.084	0.299	16.7
	0.0680	0.408	0.522	33.4		0.0925	0.095	0.305	18.1
	0.0571	0.534	0.633	30.2		0.0904	0.120	0.323	21.1
	0.0480	0.661	0.754	26.5		0.0881	0.140	0.323	23.9
	0.0361	0.793	0.908	19.8		0.0865	0.157	0.344	24.8
	0.0271	0.901	1.027	14.9		0.0849	0.168	0.344	26.1
	0.0160	1.020	1.130	9.1		0.0835	0.185	0.362	26.8
	0.0082	1.085	1.192	4.7		0.0825	0.204	0.383	27.6
							0.0805	0.218	0.383
40	0.0833	0.236			0.0793	0.231	0.398	28.9	
	0.0753	0.346			0.0651	0.426	0.493	35.3	
	0.0583	0.538			0.0604	0.465	0.538	32.7	
	0.0454	0.722			0.0567	0.526	0.566	32.8	
	0.0341	0.879			0.0536	0.590	0.602	33.0	
	0.0223	1.030			0.0491	0.629	0.645	30.1	
	0.0099	1.158			0.0456	0.676	0.697	27.9	
					0.0398	0.741	0.755	24.5	
30	0.0788	0.311			0.0369	0.793	0.794	23.2	
	0.0705	0.420			0.0302	0.838	0.860	18.5	
	0.0556	0.552			0.0249	0.893	0.915	15.3	
	0.0437	0.716			0.0220	0.948	0.956	13.7	
	0.0294	0.886			0.0169	0.996	1.008	10.5	
	0.0187	1.000			0.0131	1.038	1.048	8.2	
	0.0096	1.112			0.0092	1.070	1.087	5.7	
					0.0061	1.185	1.117	4.1	

Friction torque = 0.025.

A = 0.0904 sq. ft.

r = 8 ins.

APPENDIX.

THE HEMISPHERICAL CUP (OR ROBINSON) ANEMOMETER.

The hemispherical cup anemometer is still used as a standard instrument by the Meteorological Office, though the mode of variation of the calibration factor of the instrument with wind speed is not fully understood. It was therefore of interest to see if the present investigation threw any light on the matter.

In 1888 Dines found the normal force on a hemispherical cup and spindle at angles of yaw from 0° to 180° , the measurements being made on a whirling arm in the open air at an lV of $12.8 \text{ ft}^2/\text{sec.}$, where l = diameter of cup, V velocity of wind. (*Journal of the R. Met. Soc.*, Vol. XIV). He determined also the value of V/v for a Robinson anemometer, where v is the velocity of the centre of each cup, and found that this ratio is a function of V , varying from a value between 4 and 3 for $V = 3$ to 6 m.p.h., falling rapidly to a value between 2.2 and 2.0 for $V > 20$ m.p.h. More recently ("Observers' Handbook," Meteorological Office, 1918) the factor has been taken as 2.2, and a correction table for the particular instrument is then used to convert indicated speed to true speed. This correction is a function of velocity and the proportional error is greater at lower speeds.

Though the same instrument is used as an anemometer and as a windmill to produce power, the conditions differ in two respects. In the cases tested in this report, though low values of the applied torque were tested, the friction torque was large, and the total torque therefore never very small. For the anemometer the friction torque is reduced to a minimum. But since the experimental torque (Fig. 9) agrees with the calculated curve down to the lowest value measured, it is reasonable to suppose the calculated curve holds down to zero torque. A more serious difference lies in the value of lV required, as the scale effect on a hemispherical cup is large and complicated, and the type of flow seems to change about $lV = 6$. This was unimportant in the cases dealt with here, but as an instrument for measuring low velocities, scale effect may complicate the calibration.

Using the same notation as in the main report, *i.e.*,

V = velocity of wind, v = velocity of cup,

Q = torque, ρ = density of air,

$A = \frac{\pi d^2}{4}$ where d is diameter of cup,

r = distance from centre of cup to axis of rotation,

then in Fig. 13, V/v is plotted as a function of $Q/\rho AV^2 r$; this is the torque curve, Fig. 7, for a 4-cup anemometer in a slightly different form. When $Q = 0$, V/v is equal to 2.21. In any actual instrument the friction torque is never zero, but as V increases, $Q/\rho AV^2 r$ will approach zero and V/v should tend to this value as a limit.

Assuming Q , the friction torque, is independent of V , then V/v may be expressed as a function of $V \sqrt{\frac{\rho Ar}{Q}}$ this latter factor being a constant for each instrument. This has been done in Fig. 14, where it will be seen that the curve has the two asymptotes $V/v = 2.21$, and $V \sqrt{\frac{\rho Ar}{Q}} = 0.90$. This

latter gives the speed below which the anemometer will not run. It will not start up until a somewhat larger speed is reached, as the maximum static friction is in general greater than the running friction. If Q cannot be assumed constant, V/v is still given by Fig. 2, where, however, Q is now a function of V . These curves will only hold provided ΔV for the conditions under which the instrument works is sufficiently large for scale effect to be negligible. It is evident that, in order to make V/v as nearly constant as possible over the required speed range, $\Delta v/Q$ must be made large.
