

NATIONAL AERONAUTICAL ESTABLISHMENT
LIBRARY

N.A.E.

C.P. No. 99
(14,756)
A.R.C. Technical Report

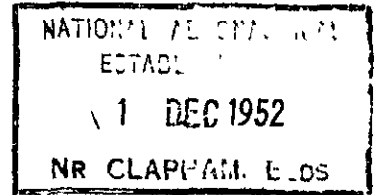

MINISTRY OF SUPPLY

AERONAUTICAL RESEARCH COUNCIL
CURRENT PAPERS

Helicopter Behaviour in the Vortex Ring Conditions

By

W. Stewart, B.Sc.

LONDON: HER MAJESTY'S STATIONERY OFFICE

1952

Price 2s. 6d. net

RAE 70-10-100 100

Technical Note No. Aero. 2131

November, 1951

ROYAL AIRCRAFT ESTABLISHMENT

Helicopter Behaviour in the Vortex Ring Conditions

by

Wm. Stewart, B.Sc.

Summary

A region of roughness, associated with the airflow conditions of the vortex ring state, occurs when a helicopter is operating in vertical or near vertical descents in the range of about 500 and 1500 ft/min. The turbulent circulating air and the rapid changes in local velocities in this flow pattern can cause serious helicopter handling difficulties. This could cause concern in a slow steep approach, particularly under instrument flying conditions.

This report describes flight experience in the vortex ring conditions with the Sikorsky R-4B, R-6 and S-51, Bell 47 and Bristol 171 helicopters. It is shown that the helicopter behaviour varies from a mild wallowing on the best type to a complete loss of control on the worst case. These effects are due to the turbulent flow changes in the vortex ring and the loss of control is thought to be caused by large changes in pitching moments on the fuselage with small displacements of the helicopter relative to the unusual flow pattern.

LIST OF CONTENTS

	<u>Page</u>
1 Introduction	3
2 Airflow conditions	3
3 Description of helicopters	4
4 Flight behaviour	4
5 Discussion	5
6 Conclusions	7

LIST OF ILLUSTRATIONS

	<u>Fig.</u>
Airflow conditions for typical helicopter	1
Typical vortex ring flow pattern	2
Drawing of Sikorsky R-4B	3
Drawing of Sikorsky R-6	4
Drawing of Sikorsky S-51	5
Drawing of Bell 47	6
Drawing of Bristol 171	7

1 Introduction

During descent of the helicopter in vertical flight or at very low forward speeds, some peculiar stability and control phenomena have been observed. This behaviour appears to be associated with the type of airflow pertaining to these flight conditions in the vortex ring state. However, the magnitude of the effects on the various types of helicopter is quite different.

This note discusses the airflow conditions associated with flight in the vortex ring state and summarises the evidence from flight experience on five types of helicopter, viz:- the Sikorsky R-4B, R-6, and S-51, Bell 47 and Bristol 171.

2 Airflow Conditions

The helicopter rotor has three distinct working conditions, described in general terms as

- (a) propeller working state,
- (b) vortex ring state,
- (c) windmill brake state.

If, for simplicity, we consider vertical flight, the propeller working state of the helicopter rotor represents vertical climb. The rotor disc is moving in the direction of the thrust and the airflow is directed downward through the rotor. The limiting condition for the propeller working state is the static thrust case or hovering.

As the helicopter descends from hovering, it enters the vortex ring state and the rotor disc is now moving in the opposite direction to the thrust that it produces. In this state, the rotor is still pushing air downwards through the rotor disc but the free air is moving upwards relative to the rotor and the air below the rotor is forced out radially. Thus, the air associated with the rotor disc does not form a regular slipstream development but there exists a circulation of air in a very turbulent state, the flow being directed downwards through the rotor, then moving radially outwards and upwards outside the rotor disc. Some of this air as it passes upward above the rotor is again drawn inward and down through the rotor, circulating in the manner from which this state derives its title viz: the vortex ring.

Beyond the vortex ring conditions exists the windmill brake state in which the rotor derives its energy from the air. The flow is upward through the rotor and the thrust is produced by slowing down the air as it passes through the rotor disc. The boundary condition between the vortex ring and windmill brake states is the condition where the upward flow of air is brought to rest at the rotor disc. This condition of no flow through the disc is referred to as ideal autorotation.

The recent flight work of Ref.1, using a smoke filament technique for slipstream visualisation, has assisted considerably in the appreciation of the flow conditions in vertical flight. In Ref.1, photographs and diagrams of the flow patterns in the various conditions are given, together with quantitative results of the flight measurements.

In forward flight, the same three working states still exist, the boundaries between the states being determined by the velocity components at the rotor disc. The vortex ring state becomes progressively smaller,

in terms of rate of descent range, with increase in forward flight speed. The boundary between the propeller and vortex ring states would be represented by level flight for the ideal case of a rotor with no tilt. However, helicopter drag makes it necessary to tilt the rotor in forward flight and the boundary, corresponding to the conditions of flight path parallel to the disc plane, follows a curve similar in shape to the angle of tilt curve. The general helicopter operating states and boundary conditions for a typical helicopter are given in fig.1.

In this report, we are interested only in the region in which the vortex ring conditions have appreciable effects on the behaviour of the helicopter. Flight tests have shown that this region extends over the range of rate of descent from about 500 to 1500 ft/min in vertical flight and decreases with forward flight speed, so that above about 10 mph no appreciable effects were noticeable. This region of roughness is also indicated in fig.1. The flow conditions may be obtained from Ref.1 but a diagram of the typical vortex ring flow pattern existing in this region is given in Fig.2. It should be noted that the extent of the region of roughness will depend to some degree on the helicopter layout and the disc loading etc, but it is unlikely to be appreciably altered from the range given in fig.1

3 Description of Helicopters

The flight tests were made on five types of helicopter, viz: Sikorsky R-4B, R-6 and S-51, Bell 47 and Bristol 171. All these helicopters are of the same configuration of one main rotor and a torque-compensating tail rotor. Descriptions of these helicopters and of their general flying qualities have been given in various R.A.E. and A.F.E.E. reports, 3,4,5,6,7.

A list of the relevant details and dimensions of the five types of helicopter are given in Table 1 and drawings in figs. 3 to 7 respectively.

4 Flight Behaviour

4.1 General

The Sikorsky R-4B was the first helicopter to receive extensive flight-testing and therefore the first type on which the vortex ring conditions were experienced. The initial experiences of this behaviour were rather alarming but it has since been found that the behaviour of the R-4B is, in fact, very much worse than any of the other types tested. Most of the investigations have been made on the R-4B and experience on it is dealt with in greater detail. The same general principles held on the other types, although the actual effects are much less serious.

The approach to the region of roughness can be made by reducing power from hovering flight or by reducing speed from forward flight. In the case of the R-4B there is not sufficient power to hover in free air and at maximum power the rate of descent is about 500 ft/min corresponding to the beginning of the region of roughness.

4.2 Sikorsky R-4B

When the helicopter is brought to the region of roughness (fig.1) there is a great deal of wallowing or unsteadiness of the helicopter accompanied by random yawing movements and a considerable increase in the vibration level. Then, a loss of control takes place in the form of a nose-down pitching. Full backward movement of the stick cannot prevent this violent nose-down pitching and the helicopter attains an angle of pitch of about 40° . Subsequently, the flight speed increases rapidly to about 40 mph with consequent loss in height before satisfactory control is regained. The shuddering throughout the helicopter and the sharp movements of the helicopter, in particular the violent nose-down pitching, are rather alarming to the pilot. This was particularly so in the first

experiences and although the pilots gained some confidence with practice, the characteristics were still considered to be vicious.

Decreasing the collective pitch, when the unsteady conditions are approached, precipitates the nose-down pitching. An increase of pitch and power, if applied immediately the unsteadiness begins, can suppress the loss of control but this is only a temporary effect on the R-4B as it has insufficient power to enable it to climb clear of the region of roughness and the loss of control will eventually occur.

4.3 Sikorsky R-6

The behaviour of the Sikorsky R-6 in the region of roughness takes the form of a general wallowing accompanied by a harsh vibration and is followed by a moderate forward tilting of the helicopter. There is often a tendency to turn to port. In general, the characteristics of the R-6 are somewhat similar to those of the R-4 but are very much less severe. The forward tilting can be kept to about 5 to 10°. Again, decreasing the collective pitch precipitates the nose-down pitching while increase of pitch and power suppresses it and the helicopter can be climbed clear of the region of roughness.

4.4 Sikorsky S-51

The behaviour of the S-51 has the same general characteristics as the R-4B and R-6 helicopters. There is the same type of wallowing but there is much less tendency to yaw and the increase in vibration is much less noticeable. The nose-down pitching takes place and, while it is much less severe than on the R-4B, it does tilt more steeply than the R-6.

4.5 Bell 47

The investigations on the Bell 47 have shown that at no time is there a complete loss of control. There is some lateral and longitudinal wallowing often accompanied by a good deal of yawing and there is the usual increase in the vibration level. There is no violent pitching as experienced on the R-4B or S-51 helicopters.

The flight path can be reasonably well maintained although coarse control corrections are necessary, which makes it appear to the pilot that there is a general loss of effectiveness in the controls.

4.6 Bristol 171

The Bristol 171 helicopter shows the most satisfactory characteristics of the five types tested, although the Bell 47 is only slightly inferior. There is the usual increase in vibration on reaching the region of roughness and a certain amount of wallowing. This behaviour is somewhat similar to that of the Bell 47 but the Bristol 171 does not seem to be as sensitive. Even so, there is a general impression of insecurity sufficient to make the pilot apprehensive.

It is fairly easy to suppress the general roughness by increasing the pitch and power and climbing clear of this region. The lower blade angles and higher blade kinetic energy make the technique of re-establishing smooth flow conditions somewhat easier on the Bristol 171 than on the other types.

5 Discussion

Summarising the flight experience in this region of roughness, it may be said that, in bad cases, there is complete loss of control, while,

in the best case, there is a general wallowing instability of the helicopter sufficient to make the pilot apprehensive. Now, this region of roughness extends to or close to the condition for a very slow steep approach as discussed in Ref.2. Such an approach would be virtually impossible on those helicopters showing the loss of control features. In the best case, it would be very disturbing to the pilot, especially under instrument flying conditions, although with considerable experience and practice it should be possible to make such an approach.

Since so few have any real experience of flight in the vortex ring conditions, it might perhaps assist in appreciating the behaviour if we consider the similarity to the sensations experienced during the stall of a fixed-wing aeroplane. The R-4B feels like an aeroplane where, on reaching the stall, there is an extremely sharp drop of the nose which the longitudinal control has negligible effect in trying to prevent. There is also the similarity in the general wallowing and shuddering before the nose-down pitching takes place and in the difficulty of anticipating precisely the instant at which the sudden nose-down pitching will take place. Applying the similarity to the other helicopters, the S-51 and R-6 would compare with aeroplanes with mild but quite definite stalling characteristics. The Bell 47 and Bristol 171 would feel similar to aeroplanes on which it is possible to make a stalled glide. Although the flight path can be maintained with coarse use of controls there is a fair amount of wallowing instability and general feeling of apprehension. It must be appreciated that in drawing this similarity with the fixed-wing aeroplane stall, we are comparing only the general flight behaviour and sensations experienced by the pilot and that there is no aerodynamic relationship in the causes of these effects i.e. there is no question of aerodynamic stalling in the helicopter rotor - a fact easily proved in that increasing the collective pitch during the behaviour has a beneficial effect.

It appears that the pitching is brought about by the effects of the flow on the fuselage. While it is not possible to treat these pitching moments in the vortex ring flow mathematically and the flight conditions are too unsteady to enable measurements to be made, a rough idea can be obtained by considering the flow patterns of Ref.1 together with the different types of fuselage on the five helicopters tested.

A check on the changes of flow over the rear fuselage was made on the Sikorsky R-4B by using long wool tufts. It was found that the airflow was very turbulent but that the general direction was downward over the rear fuselage when the region of roughness was reached. Large changes in flow direction occurred when the helicopter was showing wallowing characteristics and then, immediately before the violent nose-down pitching occurred, the flow reversed completely and was directed upward over the rear fuselage.

The Sikorsky R-4B, with its rectangular section fuselage, is known to have large changes in pitching movement with changes in flow conditions - even with relatively small flow changes in forward flight conditions, Ref.3. It is to be expected then, that the R-4B would show much more serious characteristics than the other types.

The Bristol 171 and Bell 47, which have very slim tail cones, show the best flight characteristics in the vortex ring. The better aerodynamic shape of the tail cone of the Bristol 171 is probably responsible for the better behaviour of this helicopter. In general, the behaviour of the five helicopters corresponds with what would be expected considering the probable fuselage pitching moments on each type. It shows that, while the region of roughness is fundamental to the helicopter,

proper design of the fuselage, particularly the tail cone, can largely minimise the effects on helicopter behaviour. However, the rapidly changing flow of the vortex ring conditions will always cause random changes in loading distribution along the blades and possibly also give a certain amount of fuselage buffeting. It is therefore to be expected, with any helicopter, that there will be some vibration and some general wallowing instability.

6 Conclusions

6.1 A region of roughness exists in helicopter flight at very low airspeeds in descents between 500 and 1,500 ft/min and stability and control difficulties may be experienced in this region.

6.2 The unsteady flow through the rotor causes some vibration and general wallowing instability.

6.3 In some cases, loss of control may occur and this is probably due to large changes in fuselage pitching moment for small displacements within the circulating flow associated with the vortex ring conditions.

6.4 These effects may impose limitations on the helicopter approach conditions at very low airspeeds, especially if instrument approach is considered.

6.5 Flight experience has been obtained on five types of helicopter, the results varying from loss of control to mild wallowing instability. In relation to approach under these conditions, the R-4B would be impossible; the S-51 dangerous; the R-6 very difficult; the Bell 47 and Bristol 171 just possible but there is a wallowing instability and a general feeling of insecurity and apprehension.

References

<u>Ref. No.</u>	<u>Author</u>	<u>Title, etc.</u>
1	Brotherhood	Flow through the helicopter rotor in vertical descent. R&M 2738 July, 1948
2	Stewart	Notes on helicopter approach in blind flying conditions. ARC 12,890 November, 1949
3	Stewart	Helicopter control to trim in forward flight. R&M 2733 March, 1950
4	Stewart	General handling tests of the Sikorsky R-4B helicopter. R&M 2431 October, 1946
5	Glass Mather	Sikorsky S-51 - Performance and handling tests. ARC 11,238 December, 1947
6	Birds	Hoverfly II (Sikorsky R-6) Performance and handling tests. A.F.E.E. Report Rota 2
7	Bramwell and Sissingh	General handling and stability tests on a helicopter with a stabilising bar (Bell 47D) ARC 14,441 August, 1951

TABLE 1

Principal Dimensions

Helicopter Type	Sikorsky			Bell 47	Bristol 171
	R-4B	R-6	S-51		
<u>MAIN ROTOR</u>					
Main rotor dia ft	38	37.9	48	35.13	47.17
Number of blades	3	3	3	2	3
Total blade area sq ft	65.4	65.4	115.05	35.34	
Disc area sq ft	1134	1130	1810	970	1740
Disc loading lb/sq ft	2.35	2.32	2.70	2.27	2.79
<u>TAIL ROTOR</u>					
Tail rotor dia ft	8.19	8.19	8.4	5.75	9.61
Number of blades	3	3	3	2	3
Total blade area sq ft	4.8	4.8	6.69	2.4	
Disc area sq ft	52.8	52.8	55.4	25.31	72.5
<u>FUSELAGE</u>					
Length ft	34	34	41.15	30.22	41
Maximum width ft	4.0	3.67	5.17	4.44	4.96
<u>Fuselage Width At 0.75R</u> 2π 0.75R	0.018	0.015	0.018	0.013	0.013

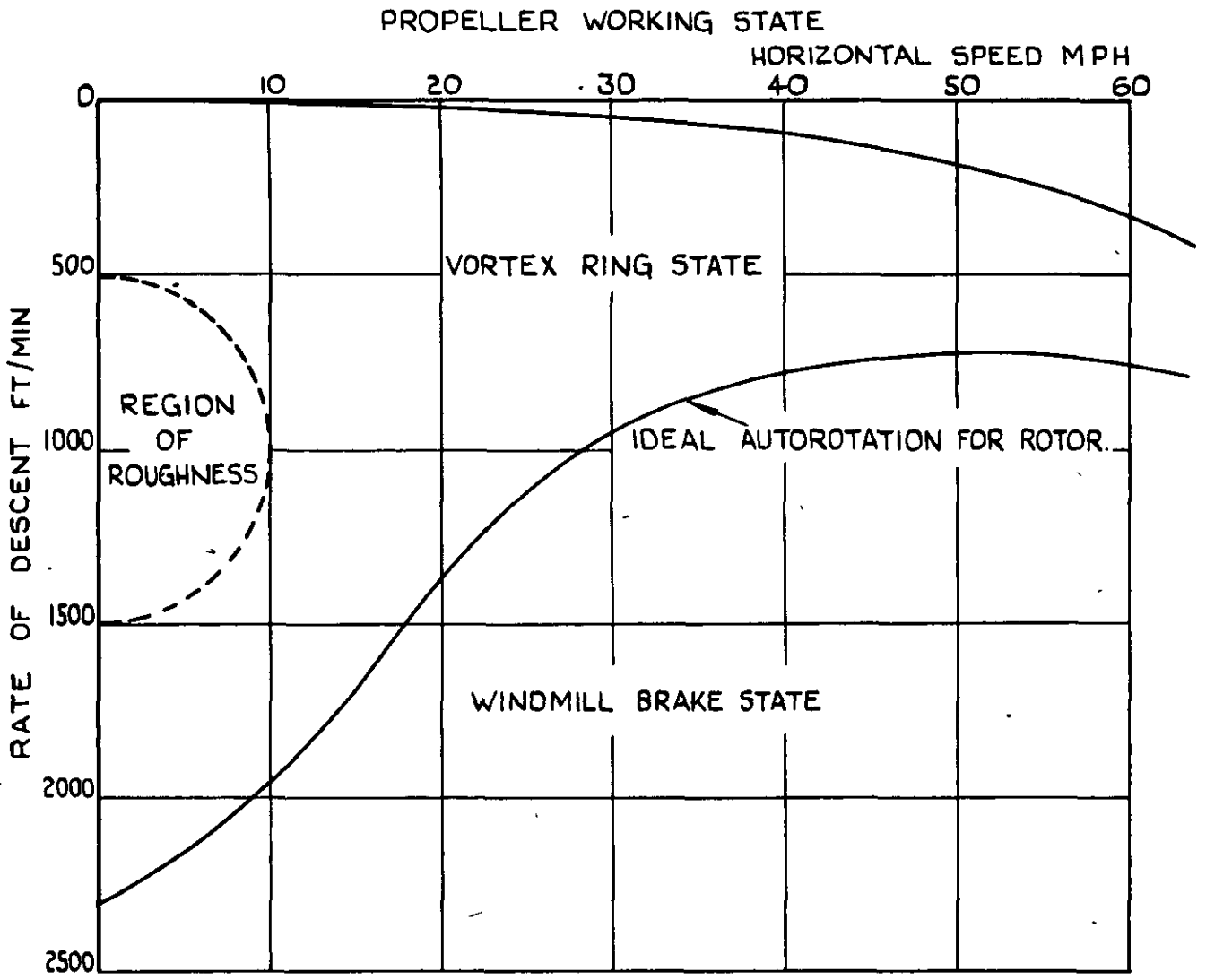

FIG.1. AIRFLOW CONDITIONS FOR TYPICAL HELICOPTER.

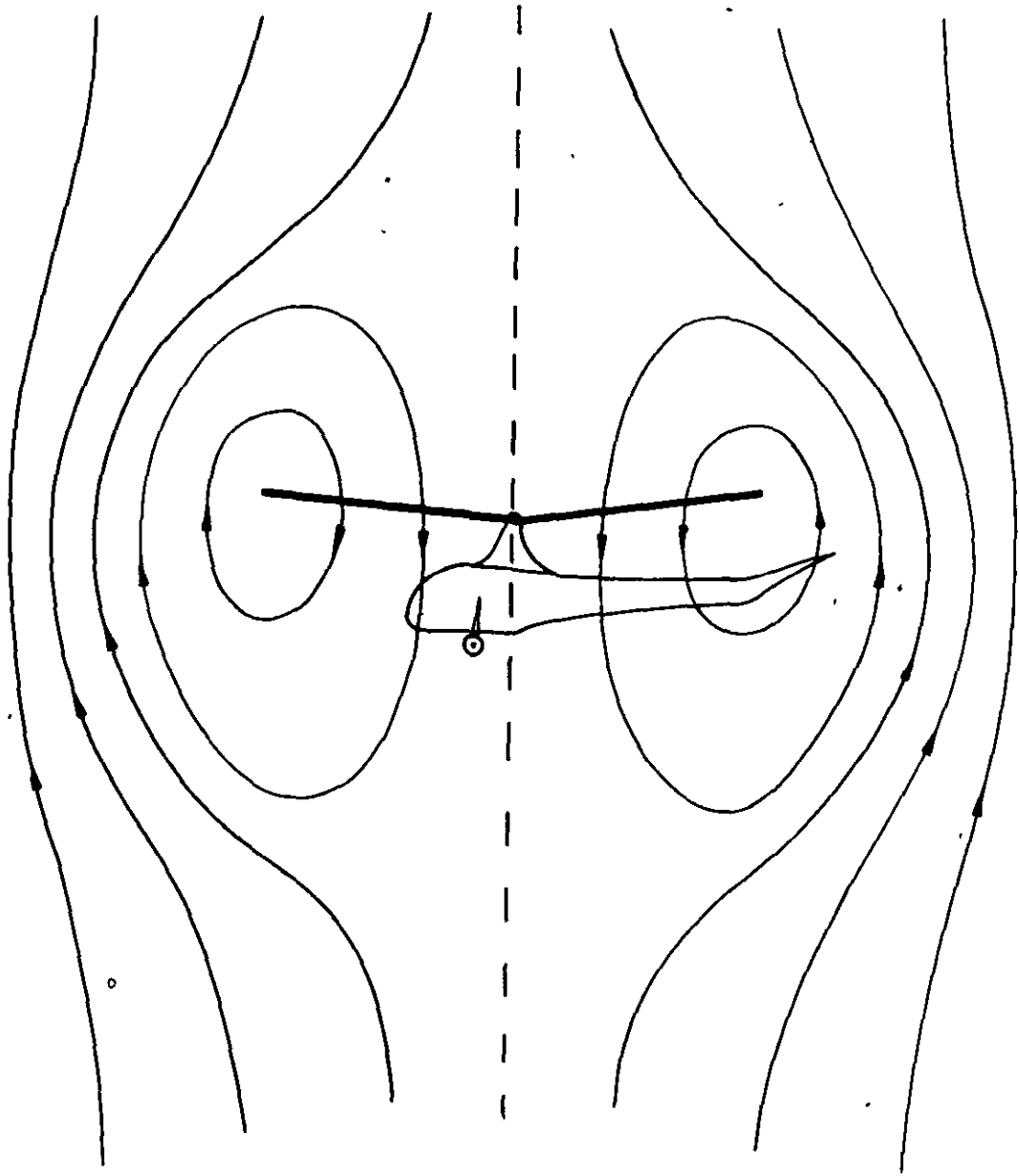

FIG.2. TYPICAL VORTEX RING FLOW PATTERN.

FIG.3.

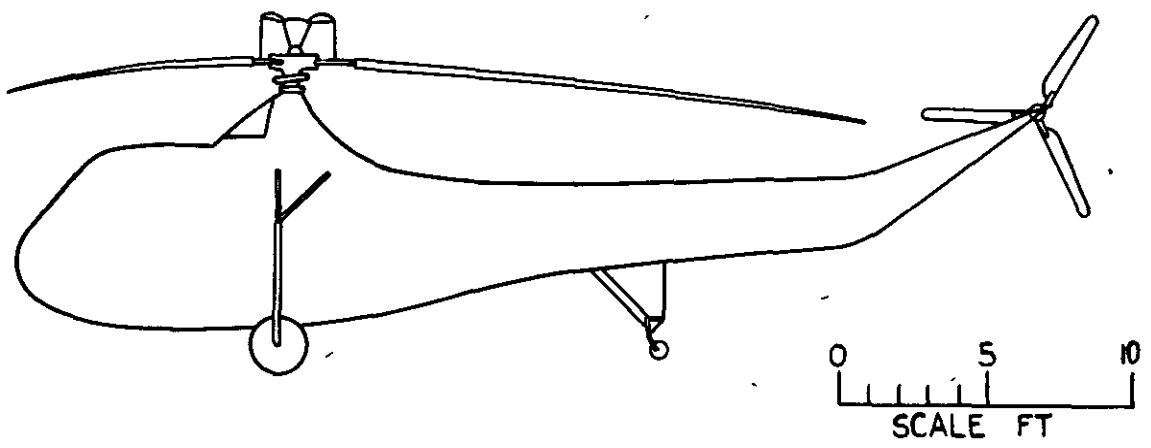
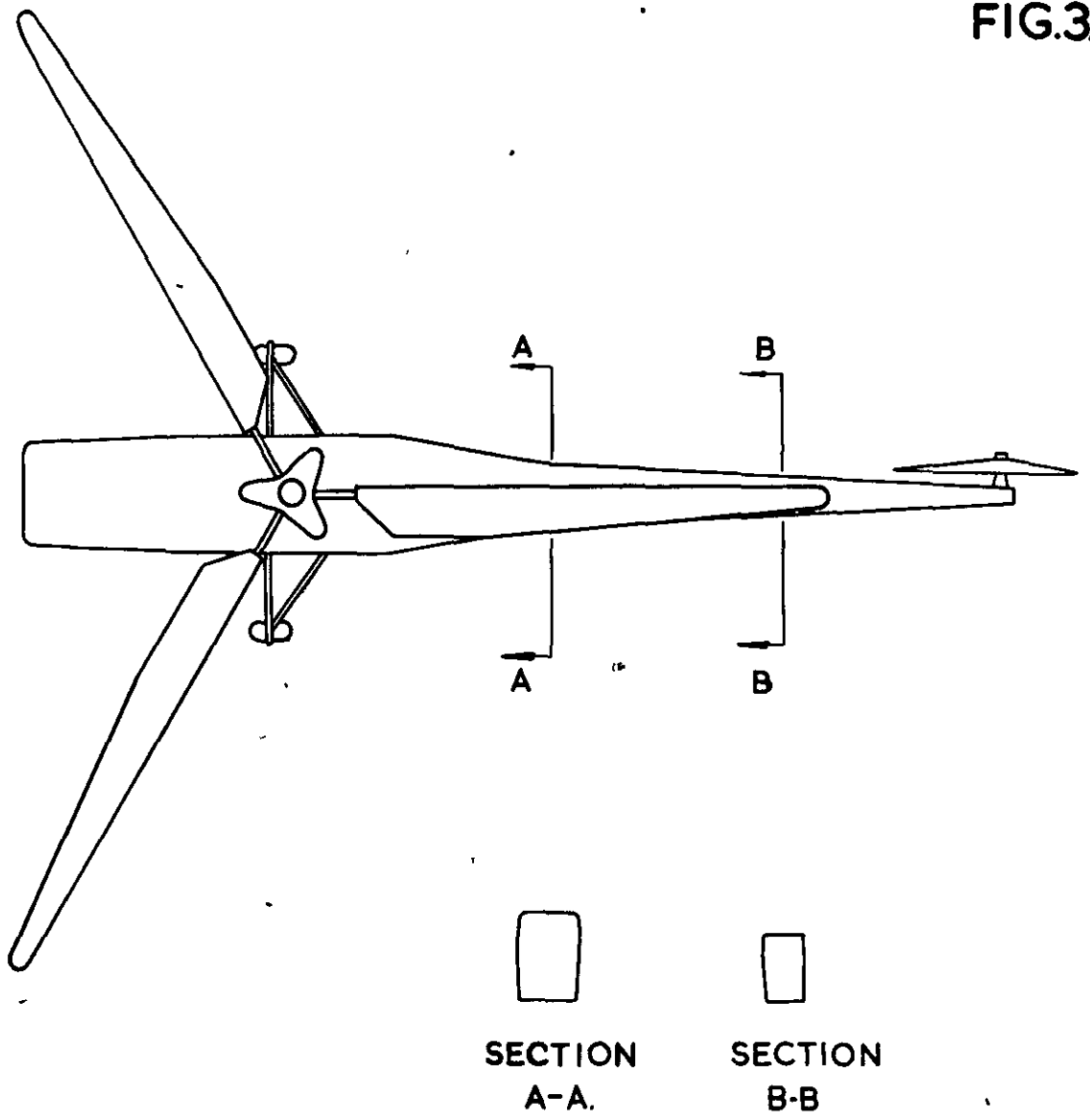

FIG.3. SIKORSKY R-4B.

FIG.4.

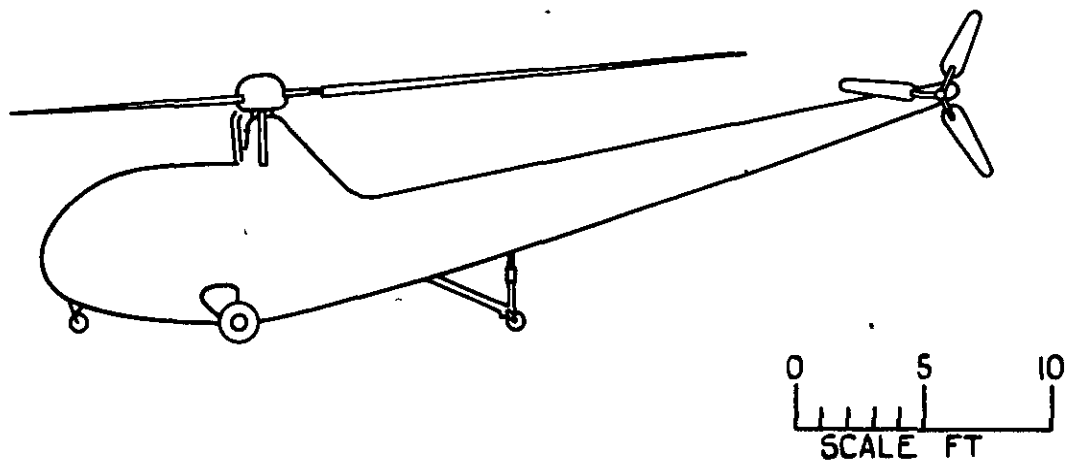
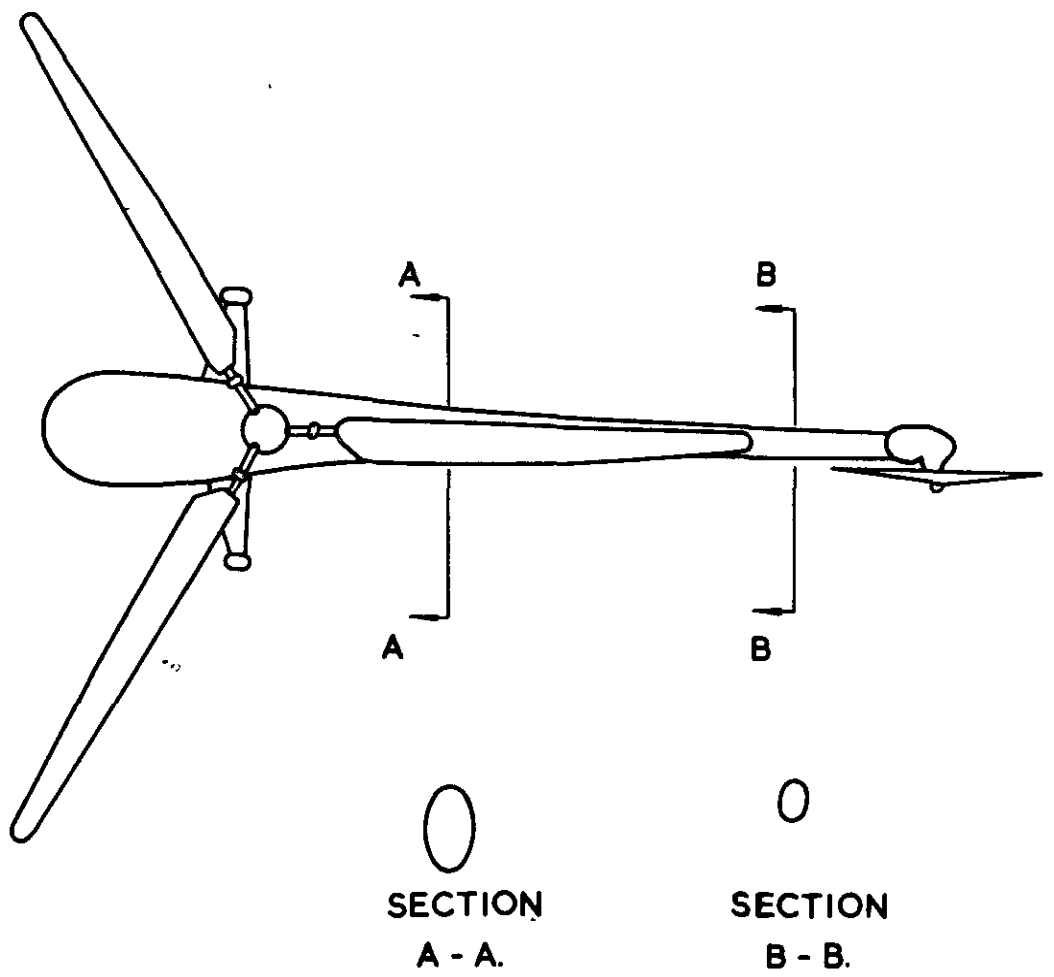

FIG.4. SIKORSKY R-6.

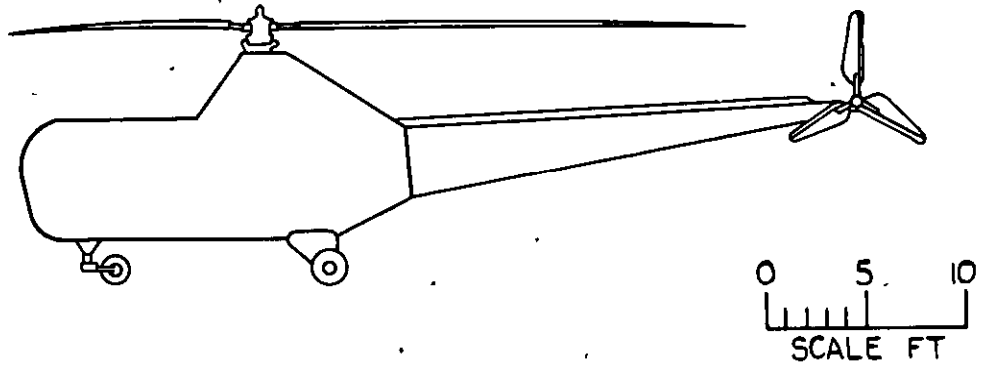
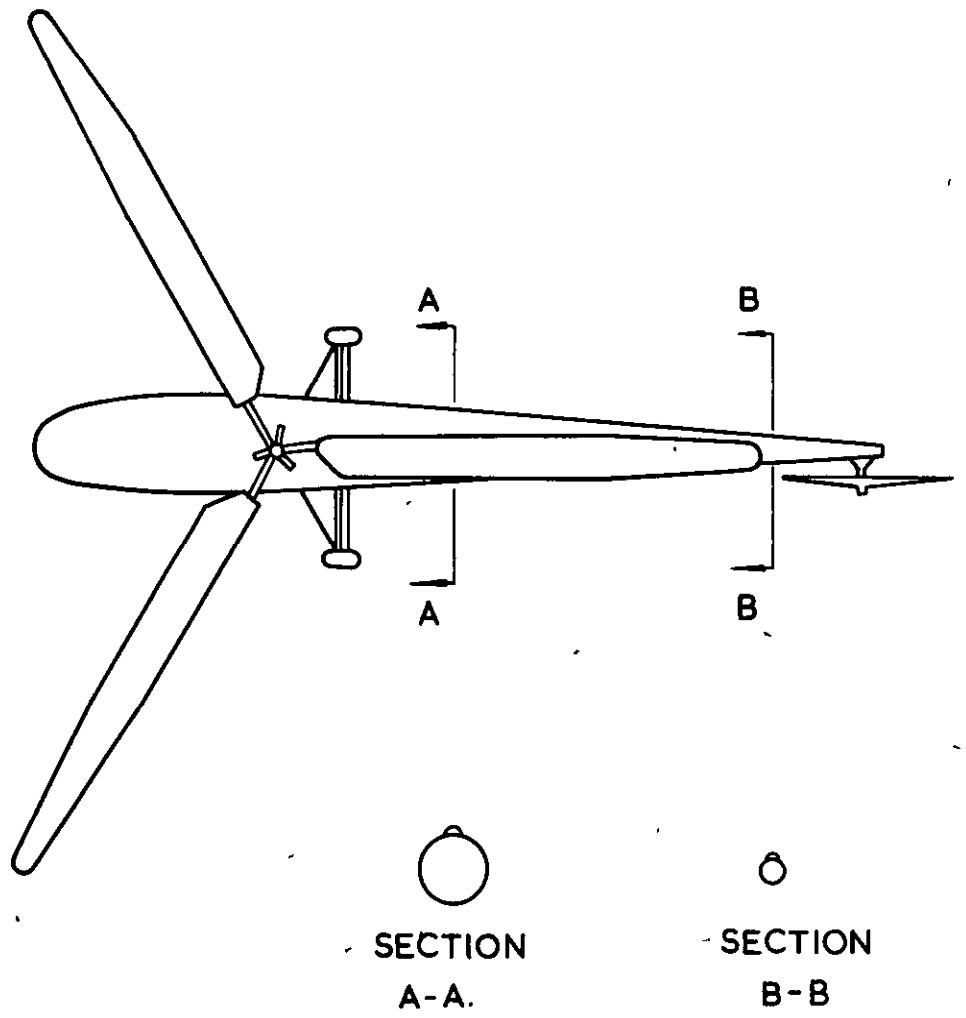
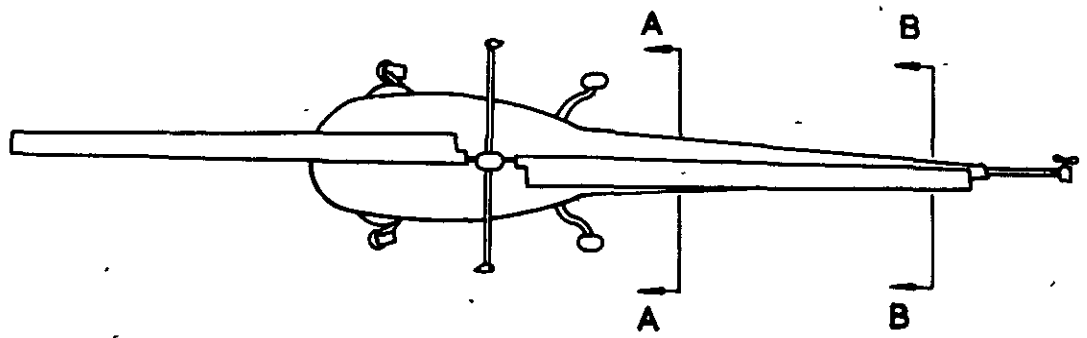

FIG.5. SIKORSKY S-51.

FIG. 6.



SECTION
A-A.

SECTION
B-B.

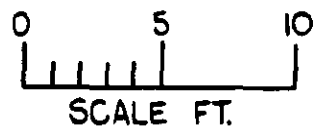
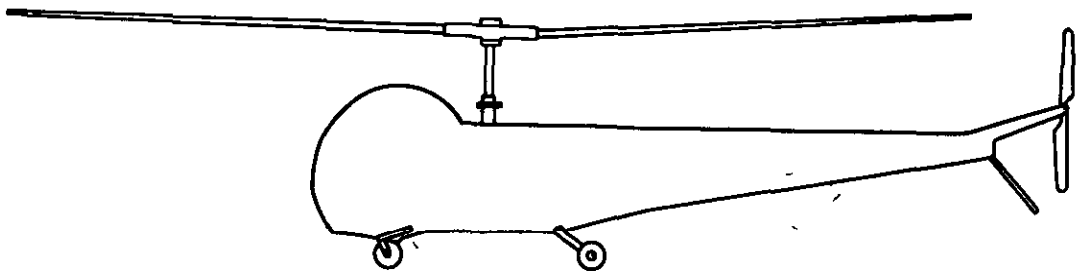

FIG. 6. BELL 47.

FIG.7

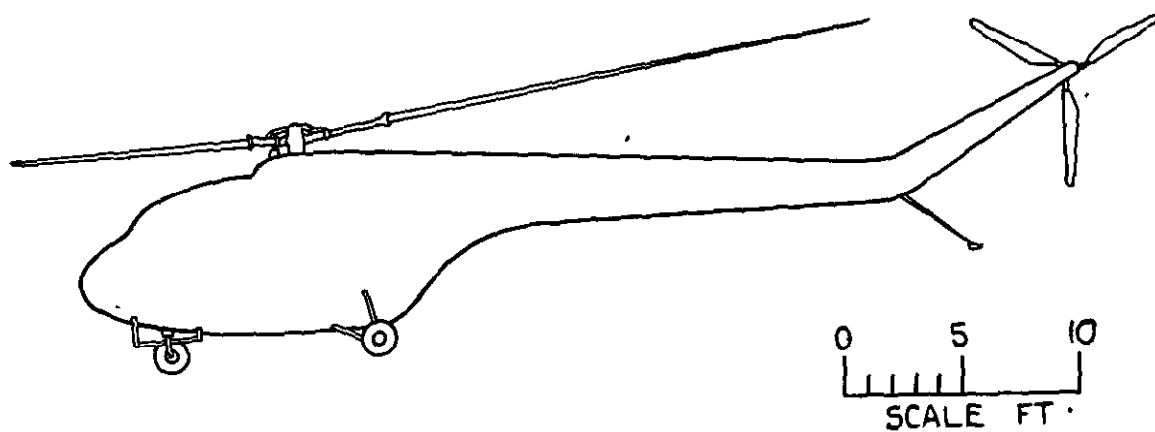
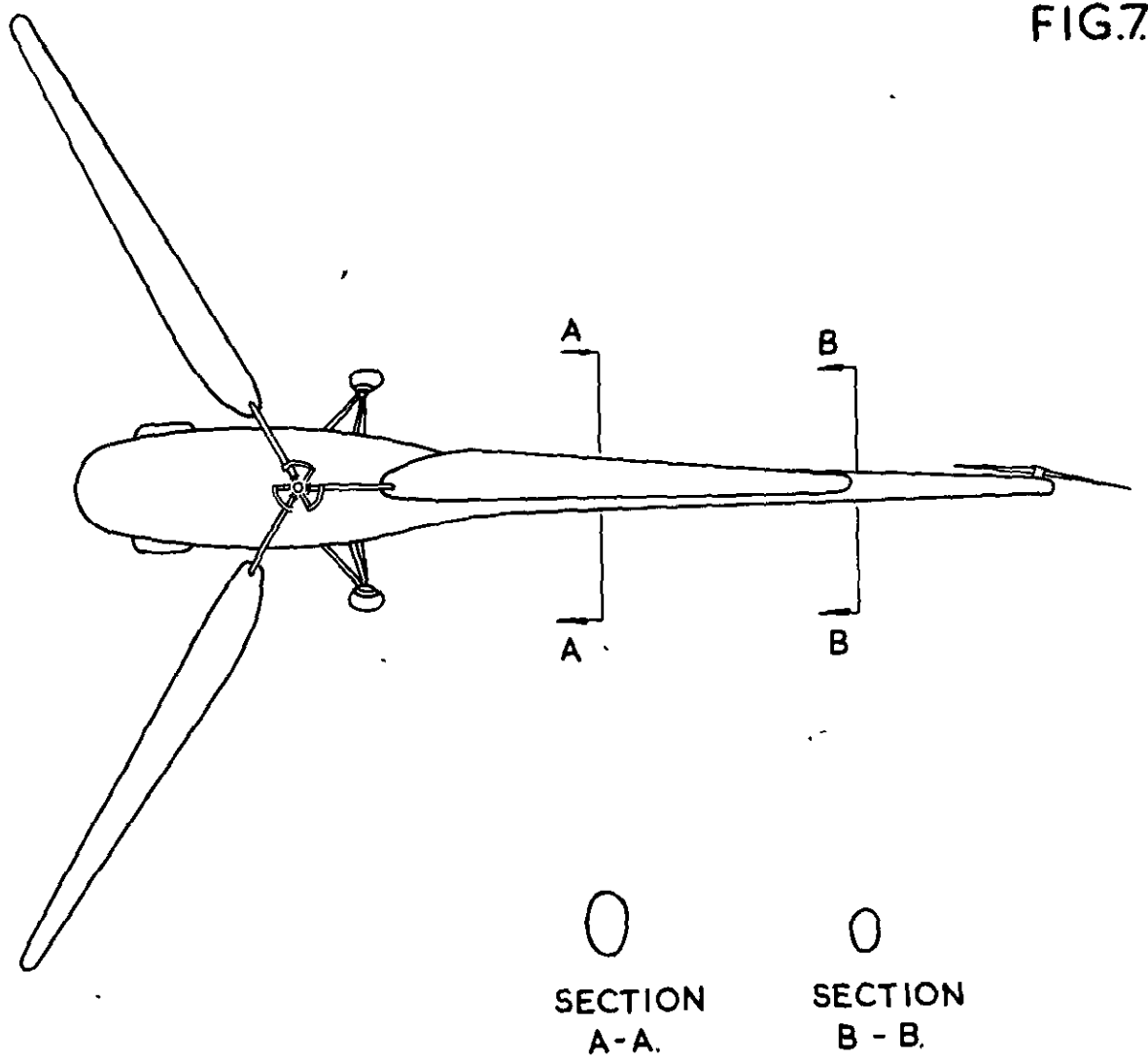

FIG.7. BRISTOL 171.

Crown Copyright Reserved

PUBLISHED BY HER MAJESTY'S STATIONERY OFFICE

To be purchased from

York House, Kingsway, LONDON, W.C.2: 429 Oxford Street, LONDON, W.1
P.O. BOX 569, LONDON, S.E.1

13a Castle Street, EDINBURGH, 2		1 St Andrew's Crescent, CARDIFF
39 King Street, MANCHESTER, 2		Tower Lane, BRISTOL, 1
2 Edmund Street, BIRMINGHAM, 3		80 Chichester Street, BELFAST

or from any Bookseller

PRINTED IN GREAT BRITAIN

1952

Price 2s. 6d. net